

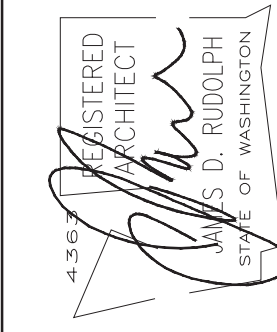

Dann Residence

RUDOLPH
ARCHITECTS
915 Rucker Avenue Everett, Washington
206 226-5588



PERMIT SET 03/11/24
REVISION 02/10/24
REVISION 04/13/25
REVISION xx/xx/xx

A New Residence For
Teddy and Megan Dann
3008 70th Avenue S.E., Mercer Island, Washington 98040

REGISTERED ARCHITECT
XXX XXX XXX
XXXX XXX XXX XX WW XXXX
XXXX XXX XXX XXX
License # XXXXXXXXXX

Standard Site Plan Notes

1. THE CITY SHALL INSPECT THE INSTALLATION OF ALL WATER, SEWER, STORM AND FOOTING DRAINS PRIOR TO CONTRACTOR BACKFILLING TRENCHES.
2. ROOF AND FOOTING DRAINS ARE TO BE CONNECTED SEPARATELY TO THE STORM DRAIN SYSTEM UNLESS OTHERWISE ALLOWED IN ACCORDANCE WITH THE PLAT CONDITIONS AND THE KING COUNTY SURFACE WATER DESIGN MANUAL OR AS APPROVED BY THE CITY IN WRITING.
3. ALL ROCKERY OR RETAINING WALL DRAINS SHALL BE CONNECTED TO THE STORM DRAIN SYSTEM, DISCHARGED APPROPRIATELY PER KCSUDM, OR AS APPROVED BY THE CITY IN WRITING.
4. ANY CHANGES TO THE APPROVED PLANS MUST BE APPROVED BY THE CITY IN WRITING.
5. NOTE: ANY WALL OVER 4 FEET IN HEIGHT, OR WITH A SURCHARGED LATERAL LOAD, MUST BE ACCOMPANIED BY AN ENGINEER'S STAMP. WALLS SHALL NOT BE USED TO SUPPORT DRIVEWAYS OR SIDEWALKS UNLESS ACCOMPANIED BY AN ENGINEER'S STAMP.
6. CONSTRUCTION HOURS ARE 7:00 AM TO 8:00 PM ON WEEKDAYS AND 9:00 AM TO 6:00 PM ON SATURDAYS & HOLIDAYS. WORK IS NOT ALLOWED ON SUNDAYS.
7. NO MATERIALS OR EQUIPMENT SHALL BE PLACED OR STORED ON PUBLIC STREETS AT ANY TIME.
8. NO WORK IS ALLOWED WITHIN THE PUBLIC RIGHT-OF-WAY UNTIL A RIGHT-OF-WAY PERMIT HAS BEEN ISSUED AND THE CITY HAS BEEN NOTIFIED AT LEAST 24 HOURS IN ADVANCE OF STARTING WORK WITHIN THE RIGHT-OF-WAY PERMIT.
9. ALL PROJECTS ARE REQUIRED TO SUBMIT REQUESTS FOR VARIANCES TO THE CITY INTERIM PUBLIC WORKS STANDARDS (WITH RESPECT TO DRIVEWAY SLOPE, WIDTH AND LOCATION) IN WRITING. DETAILED DRAWING SHALL ACCOMPANY REQUESTS IF NECESSARY.

Drawing Index

PROJECT DATA / NOTES	O1
DOOR & WINDOW SCHEDULES	O1
SITE PLAN	A1
DEMOLITION SITE PLAN	A2
LOWER FLOOR PLAN	A3
MAIN FLOOR PLAN	A4
UPPER FLOOR PLAN	A5
UPPER FLOOR PLAN	A6
NORTH & SOUTH ELEVATION	A7
EAST & WEST ELEVATION	A8
BUILDING SECTIONS A-A B-B	A9
BUILDING SECTIONS C-C	A10
LOWER FLOOR REFLECTED CEILING PLAN	A11
MAIN FLOOR REFLECTED CEILING PLAN	A12
UPPER FLOOR REFLECTED CEILING PLAN	A13
SURVEY	O2

Permit Number

2403-079

STRUCTURAL NOTES	S1
FOUNDATION PLAN	S2
FOUNDATION MAIN FLOOR FRAMING PLAN	S3
UPPER FLOOR FRAMING PLAN	S4
ROOF FRAMING PLAN	S5
STRUCTURAL DETAILS	S6
STRUCTURAL DETAILS	S7
CIVIL T.E.S.C. PLAN	C0
CIVIL T.E.S.C. DETAILS	C1
CIVIL DRAINAGE PLAN	C2

NOTE :
 Per WSEC R402.4, The building thermal Envelope shall be constructed to limit air leakage. The results of the test shall be signed by the party conducting the test and provided to the code official (R402.4.1.2).
 Per WSEC R403.1.1, at least one thermostat per dwelling unit shall be capable of controlling the heating and cooling system on a daily schedule.
 Per WSEC R403.2.2, Ducts, air handlers, and filter boxes shall be sealed.
 Per WSEC R404.1, A minimum of 90 percent of the lamps in permanently installed lighting fixtures shall be high-efficacy lamps.
 NOTE :
 PER MICC A107.1 all new construction requires a NFPA 13d Fire Sprinkler System. In addition due to roadway width deficiency a NFPA 72-Chapter 29 Monitored Fire Alarm System will be required per NFPA and CoMI Standards. Note this may take the place of a "line voltage" smoke detection system per IRC 314

Dann Residence
 3008 70th Avenue S.E.
 Mercer Island WA 98040

September 27, 2024

RUDOLPH
 architects

Note: See Section For Mullion Placement

WINDOW SCHEDULE

MARK	SIZE	S.F.	DESCRIPTION	MANUFACTURER & u Value	ROOM	COMMENTS
NORTH						
N1	3'-2" x 6'-0"	3.16	6.00	18.96	Fixed	TDL
N4 / W6	3'-6" x 5'-6" X 1'-8" x 5'-6"	3.50	5.50	19.25	Fixed	Corner TDL
N5	5'-0" x 5'-6"	5.00	5.50	27.50	French Casement	TDL
N6 / W7	3'-6" x 5'-6" X 3'-0" x 5'-6"	3.50	8.41	29.44	Fixed	Corner TDL
				95.15	Sub Total	
EAST						
E1	5'-0" x 4'-3"	5.00	4.25	21.25	French Casement	TDL
E2	5'-0" x 6'-0"	5.00	6.00	30.00	French Casement	TDL
E3	6'-0" x 4'-0" Verify	6.00	4.00	24.00	Fixed	
E8	5'-0" x 5'-6"	5.00	5.50	27.50	French Casement	TDL
E10	6'-0" x 16'-6"	6.00	16.50	99.00	Fixed	TDL Verify
E11	5'-0" x 5'-6"	5.00	5.50	27.50	French Casement	TDL
				178.00	Sub Total	
SOUTH						
S3 / W9	3'-6" x 5'-6" X 3'-0" x 5'-6"	3.50	5.50	19.25	Fixed	Corner TDL
S4	2'-6" x 5'-6"	3.00	5.50	16.50	Casement	TDL
S5 / W10	3'-6" x 2'-8 1/2" X 3'-0" x 2'-8 1/2"	3.50	2.70	9.45	Fixed	Corner Align Match Mullion Layout
				45.20	Sub Total	
WEST						
W1	6'-0" x 1'-6"	6.00	1.50	9.00	Awning	
W2	4'-0" x 6'-0"	4.00	6.00	24.00	Fixed	TDL
W3	7'-8" x 8'-5"	7.66	6.00	45.96	Fixed	TDL Full Height Mullied With Spandral Glass W8 At Upper Floor Line
W4	4'-0" x 6'-0"	4.00	6.00	24.00	Fixed	TDL
W6 / N4	1'-8" x 5'-6" X 3'-6" x 5'-6"	3.50	5.50	19.25	Fixed	Corner TDL
W7 / N6	3'-0" x 5'-6" X 3'-6" x 5'-6"	3.50	8.41	29.44	Fixed	Corner TDL
W8	7'-8" x 10'-7" S.G.	7.66	10.58	81.04	Fixed	TDL Full Height Mullied With Spandral Glass W3 At Upper Floor Line
W9 / S3	3'-0" x 5'-6" X 3'-6" x 5'-6"	3.50	8.41	29.44	Fixed	Corner TDL
W10 / S5	3'-0" x 2'-8 1/2" X 3'-0" x 2'-8 1/2"	3.00	2.70	8.10	Fixed	Corner Align Match Mullion Layout
W11	5'-0" x 5'-6"	5.00	5.50	27.50	French Casement	TDL
				194.76	Sub Total	
SKYLIGHTS						
R1	2'-0" x 2'-0"	2.00	2.00	4.00	Operabal	
				4.00	Sub Total	
				4.00	TOTAL S.F. GLASS SKYLIGHT	

Dann Residence
 3008 70th Avenue S.E.
 Mercer Island WA 98040

September 20, 2024

RUDOLPH
 architects

DOOR SCHEDULE

MARK	SIZE	DESCRIPTION	MATERIAL	FINISH	STOPS	RATING	HDW.
LOWER FLOOR							
001 A	3'-0" x 7'-0" x 1 3/4"	Five Flat Panel Square Stops	Wood Solid Core	P3	Wall		Lockset Automatic Hinge
001 B	2'-6" x 7'-0" x 1 3/4"	Five Flat Panel Square Stops	Wood Solid Core	P3	Wall		Passage
002 A	2'-6" x 7'-0" x 1 3/4"	Five Flat Panel Square Stops	Wood Solid Core	P3	Wall		Passage
002 B	2'-6" x 7'-0" x 1 3/4"	Pair Five Flat Panel Square Stops	Wood Solid Core	P3	Wall		Dummy W/ Roller Catch
004 A	16'-0" x 7'-0" x 1 3/4"	Custom Four Section Carage Door	Wood Clad	P3	Wall		Horizontal 1x5 Clear Re-Sawn Cedar Graded Vjoint Exposure Stain
005 A	2'-6" x 7'-0" x 1 3/4"	Five Flat Panel Square Stops	Wood Solid Core	P3	Wall		Passage
006 A	2'-6" x 7'-0" x 1 3/4"	Five Flat Panel Square Stops	Wood Solid Core	P3	Wall		Lockset
007 A	2'-2" x 7'-0" x 1 3/4"	Five Flat Panel Square Stops	Wood Solid Core	P3	Wall		Privacy
007 B	5'-0" x 7'-10" x 1/2"	Agglite Bronson Estate Series Swing	Glass	Wax		Temp.	1/2" Rimless Estate Series
MAIN FLOOR							
100 A	5'-0" x 9'-0" x 2 1/4"	Custom Pivot 10 Panel W/ One Vertical Glass Panel	Wood Solid Core W/ Glass	P3	Floor	Temp.	Morticed Lockset W/ Dead Bolt Insul Glass and SS Accents See Details
101 A	13'-11" x 9'-0" x 1 3/4"	XOOX Kolbe Vistalux Sliding Glass Door	Wood /Glass Alu Clad	P3	Wall	Temp.	Factory Hardware
105 A	13'-11" x 9'-0" x 1 3/4"	Kolbe Vistalux Pocked 4 Panel Sliding Glass Door	Wood Solid Core	P3	Wall		Factory Hardware
107 A	2'-6" x 8'-0" x 1 3/4"	Pair Five Flat Panel Square Stops	Wood Solid Core	P3	Wall		Dummy W/ Roller Catch
108 A	2'-6" x 8'-0" x 1 3/4"	Five Flat Panel Square Stops	Wood Solid Core	P3	Wall		Privacy
109 A	2'-6" x 8'-0" x 1 3/4"	Five Flat Panel Square Stops	Wood Solid Core	P3	Wall		Lockset
UPPER FLOOR							
200 A	2'-6" x 7'-0" x 1 3/4"	Store Door Kolbe Vistalux Patio Mullied To A Transom 2'-8" x 2'-8"	Wood /Glass Alu Clad	P3	Wall	Temp.	Lockset 3 Point Latch
201 A	2'-6" x 8'-0" x 1 3/4"	Five Flat Panel Square Stops	Wood Solid Core	P3	Wall		Passage
201 B	2'-6" x 8'-0" x 1 3/4"	Pair Five Flat Panel Square Stops	Wood Solid Core	P3	Wall		Dummy W/ Roller Catch
203 A	2'-6" x 8'-0" x 1 3/4"	Five Flat Panel Square Stops	Wood Solid Core	P3	Wall		Lockset
203 B	2'-8" x 7'-0" x 1 3/4"	Store Door Kolbe Vistalux Patio Mullied To A Transom 2'-10" x 2'-8"	Wood /Glass Alu Clad	P3	Wall	Temp.	Lockset 3 Point Latch
204 A	2'-6" x 8'-0" x 1 3/4"	Store Door Pocket	Wood Solid Core	P3	Wall		Passage Heavy Duty Pocket Track Obscure Milk Glass
204 B	2'-6" x 8'-0" x 1 3/4"	Store Door Pocket	Wood Solid Core	P3	Wall		Privacy Heavy Duty Pocket Track Obscure Milk Glass
204 C	6'-0" x 9'-0" x 1/2"	Agglite Bronson Estate Series Barn	Glass	Wax		Temp.	1/2" Rimless 1'-9" Corner Estate Series
205 A	2'-6" x 8'-0" x 1 3/4"	Five Flat Panel Square Stops	Wood Solid Core	P3	Wall		Passage Heavy Duty Pocket Track Obscure Milk Glass
206 A	2'-6" x 8'-0" x 1 3/4"	Five Flat Panel Square Stops	Wood Solid Core	P3	Wall		Passage
206 B	1'-6" x 8'-0" x 1 3/4"	Pair Five Flat Panel Square Stops	Wood Solid Core	P3	Wall		Dummy W/ Roller Catch
207 A	2'-6" x 8'-0" x 1 3/4"	Five Flat Panel Square Stops	Wood Solid Core	P3	Wall		Privacy
207 B	5'-0" x 9'-0" x 1/2"	Agglite Bronson Estate Series Barn	Glass	Wax		Temp.	1/2" Rimless Estate Series
208 A	2'-6" x 8'-0" x 1 3/4"	Five Flat Panel Square Stops	Wood Solid Core	P3	Wall		Passage

Applicable Codes

- 2018 International Building Code (IBC)
- 2018 International Residential Code (IRC)
- 2018 International Mechanical Code (IMC)
- 2018 International Fuel Gas Code (IFGC)
- 2018 Uniform Plumbing Code (UPC)
- 2018 International Fire Code (IFC)
- Washington State Energy Code (WSEC)
- ICC/ANSI A117.1-09,
- Accessible and Usable Buildings and
- Facilities, with statewide and City amendments

NOTE :
 Air leakage control WSRC M1507.3 Option 2.3
 Efficient Ventilation

Other Agencies Phone and Contact Information

FEDERAL GOVERNMENT		
General Information	(Toll Free)	800-424-4995
Environmental Protection Agency	(Toll Free)	800-424-4EPA
	(Local)	206-553-1200
US Army Corps of Engineers	(Regulatory Branch)	206-764-3495
(work in waters of the United States, including adjacent wetlands, piers, bulkheads, fills, etc.)		
US Soil Conservation Service	(Local)	206-764-3325
(soils testing)		
STATE OF WASHINGTON		
General Information	(Toll Free)	800-321-2808
Contractor's License	(Bellevue)	425-990-1400
	(Olympia)	360-956-5226

Contractor Information	(Toll Free)	800-647-0982
Department of Ecology	(Local)	425-649-7000
Department of Fish and Wildlife	(Regional)	425-775-1311
Fisheries Hotline	(Olympia)	206-976-3200
Receptionist	(Electrical)	206-902-2200
Department of Labor and Industries		206-248-6630
South of Renton/Maple Valley Highway		206-453-6589
North of Renton/Maple Valley Highway	(Olympia)	360-902-2200
Elevator Permits	(Toll Free)	800-562-6010
Department of Natural Resources		

UTILITIES		
Mercer Island Sewer and Water District		206-xxx-xxxx
OTHER		
Utilities Underground Location Center	(Toll Free)	800-424-5555
PLEASE call 2 business days before you dig, utilities mark their lines!		
Puget Sound Air Pollution Control Agency		206-343-8800
Burn Ban Information	(24 Hour Recording)	800-595-4341

KING COUNTY		
Department of Assessments		206-296-7300
Department of Public Health		206-296-4932
Division of Records and Elections		206-296-1570

RUDOLPH
 ARCHITECTS
 915 Rucker Avenue Everett, Washington
 206-226-5588

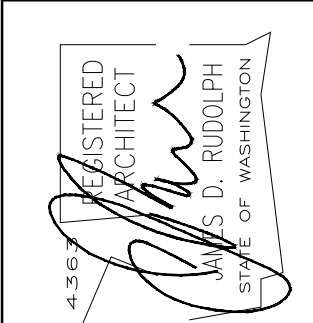

PERMIT SET 03/11/24
 REVISION 02/10/24
 REVISION 04/13/25
 REVISION xx/xx/xx

A New Residence For
Teddy and Megan Dann
 3008 70th Avenue S.E. Mercer Island Washington 98040

00000000000000000000000000000000
 License # XXXXXXXXXX

01

Lot Slope Calculation

HIGH POINT ELEVATION SOUTH EAST CORNER 291.70'
 LOW POINT ELEVATION SOUTH WEST CORNER 283.20'
 LOT SLOPE = $\frac{ELEV. DIFFERENCE}{DISTANCE BETWEEN POINTS} = \frac{13.50'}{99.96'} = 13.50\%$

Note :

Gross Floor Area Allowed is adjusted Zone R- 8.4 40%
 Allowances 3.a. The Gross Floor Area for lots with an area of less than 7,500 sq.ft. or less may be the lesser of 3,000 sq.ft. or 45% of the Lot Area.

Lot Coverage Calculations

AREA OF LOT: 5,971.00 SQ. FT.
 ASSESSORS PARCEL NUMBER: # 174501315
 AREA OF LOT COVERAGE: 40% MAX ALLOWED 2,388.40 SQ. FT.

AREA OF MAIN STRUCTURE ROOF AREA 1819.00 SQ. FT.
 AREA OF VEHICULAR USE PAVED 362.50 SQ. FT.
 AREA COVERED PATIOS AND DECKS 61.00 SQ. FT.
 AREA OF TOTAL LOT COVERAGE 2242.50 SQ. FT.
 PERCENTAGE OF TOTAL LOT COVERAGE 37.56 % ACTUAL

AREA OF HARDSCAPE: 9 % MAX ALLOWED 537.39 SQ. FT.
 AREA OF UN-USED LOT COVERAGE: 2.45% ALLOWED 146.29 SQ. FT.
 603.68 SQ. FT. = 11.45% ALLOWED

AREA OF UNCOVERED DECKS 132.75 SQ. FT.
 AREA OF WALKWAYS 302.75 SQ. FT.
 AREA OF STAIRS 89.75 SQ. FT.
 AREA OF RETAINING WALLS & ROCKERIES 158.00 SQ. FT.

AREA OF TOTAL HARDSCAPE COVERAGE 603.25 SQ. FT.
 PERCENTAGE OF TOTAL HARDSCAPE COVERAGE 11.44 % ACTUAL

Gross Floor Area

GROSS FLOOR AREA CALC. MUST BE LESS THAN 45% OF PROP
 AREA OF LOT 5971.00 x .45% 2,686.95 SQ. FT.
 FLOOR AREA TOTAL: 45% ALLOWED R0.4 2,686.95 SQ. FT.

UPPER FLOOR AREA: 1,099.00 SQ. FT. GROSS
 MAIN FLOOR AREA: 1,483.75 SQ. FT. GROSS
 EXCLUDED STAIR AREA -106.50 SQ. FT. EXCLUDED
 MAIN FLOOR AREA NET F.A.R.: 1,371.25 SQ. FT. MAIN LESS STAIR NET
 BASEMENT FLOOR AREA 1,465.50 SQ. FT. GROSS
 EXCLUDED BASEMENT AREA -1,254.89 SQ. FT. EXCLUDED
 BASEMENT FLOOR AREA NET F.A.R.: 210.62 SQ. FT. BASEMENT NET
 TOTAL COMBINED FLOOR AREAS: 4,049.25 SQ. FT. GROSS
 TOTAL COMBINED FLOOR AREA NET F.A.R.: 2,686.87 SQ. FT. F.A.R.
 F.A.R. CALCULATION FLOOR AREA RATIO 44.99 % ACTUAL

Building Heights

PROPOSED MAIN FLOOR ELEVATION ELEV. 293.00'
 AVERAGE BUILDING ELEVATION M.I. ELEV. 291.00'
 MAX RIDGE ALLOWED MERCER ISLAND ELEV. 321.00'
 PROPOSED TOP OF RIDGE ELEV. 316.68'
 MAX ALLOWED RIDGE DOWNSIDE 30 FT. ELEV. 313.58'
 PROPOSED PLATE DOWNSIDE 30 FT. ELEV. 313.58'
 BASEMENT SLAB ELEVATION ELEV. 283.75'
 SEE HEIGHT TABLE A.B.E. CALCULATION UPPER RIGHT THIS PAGE

PROPOSED MAIN FLOOR EL. 293.00'
 TOP OF SUB FL.

Legal Description

LOTS 19 AND 20, BLOCK 7, EAST SEATTLE ACCORDING TO THE PLAT THEREOF, RECORDED IN VOLUME 3 OF PLATS, PAGE 22, IN KING COUNTY, WASHINGTON. DEED #20211206001036

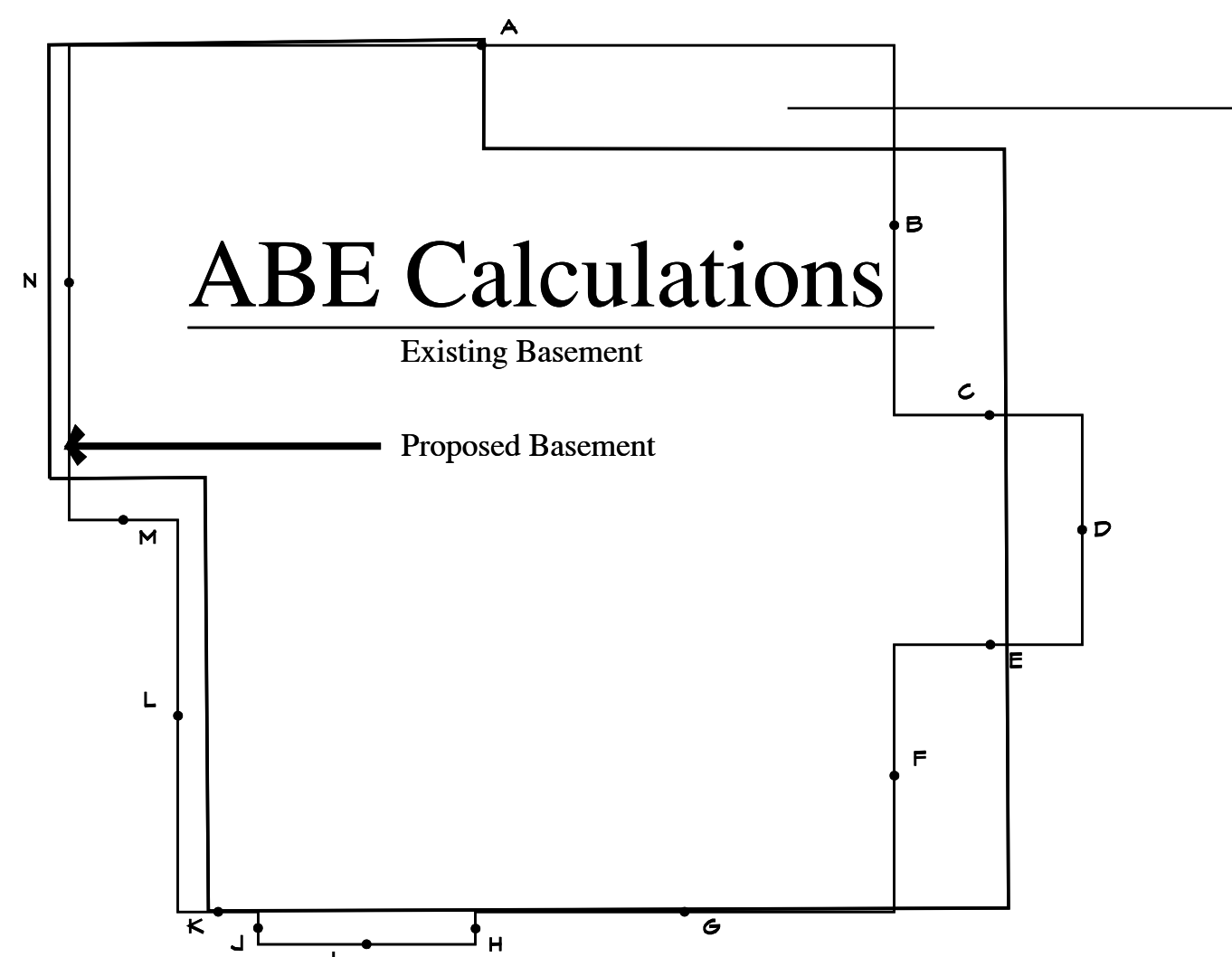

(ABE) = 15,266.65 / 176.18' = 291.00' AVERAGE BUILDING ELEVATION

ABE Calculations

Dann Residence February 20, 2024

Average Building Elevation Calculation Mercer Island

Mark	G = Lowest Grade El.	SL = Segment length	G. x SL.	SL = Segment length	SL Feet
Mark A	G Elev. = 292.90	38.00 Feet	11130.20	38.00	38.00
Mark B	G Elev. = 292.90	17.08 Feet	5002.73	17.08	17.08
Mark C	G Elev. = 292.90	8.66 Feet	2536.51	8.66	8.66
Mark D	G Elev. = 292.50	10.58 Feet	3094.65	10.58	10.58
Mark E	G Elev. = 292.90	8.66 Feet	2536.51	8.66	8.66
Mark F	G Elev. = 292.90	12.29 Feet	3599.74	12.29	12.29
Mark G	G Elev. = 292.90	19.29 Feet	5650.04	19.29	19.29
Mark H	G Elev. = 287.00	1.50 Feet	430.50	1.50	1.50
Mark I	G Elev. = 288.50	10.00 Feet	2885.00	10.00	10.00
Mark J	G Elev. = 288.50	1.50 Feet	432.75	1.50	1.50
Mark K	G Elev. = 288.15	3.70 Feet	1066.16	3.70	3.70
Mark L	G Elev. = 288.94	18.04 Feet	5212.48	18.04	18.04
Mark M	G Elev. = 292.75	5.00 Feet	1463.75	5.00	5.00
Mark N	G Elev. = 284.60	21.88 Feet	6225.63	21.88	21.88

Total Wall Segments Length 176.18 51266.65 176.18

Total Elevation Height x Length 51266.65 H.S.L. = Sum of (G Grade Lowest x SL Segment Length)
 Sum of (Wall Segments)

Average Building Elevation = $\frac{51266.65}{176.18} = 291.00$ ABE

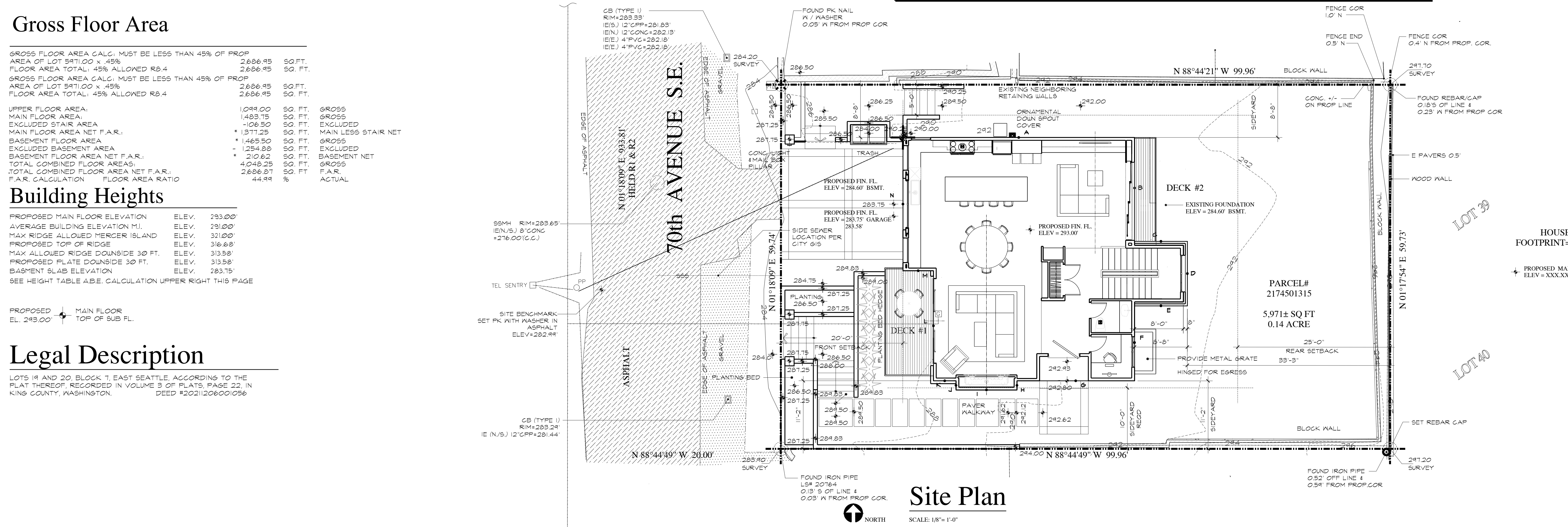

Site Plan

SCALE: 1/8" = 1'-0"

Note :

ALL RETAINING WALLS AND/OR ROCKERIES SHALL NOT EXCEED EITHER 12 INCHES IN HEIGHT FOR FILL SLOPES OF 1:4 INCHES IN HEIGHT FOR CUT SLOPES FROM EXISTING OR FINISHED GRADE TO THE TOP OF THE WALL AT ANY POINT WITHIN REQUIRED YARDS PER MICC 19.02.050(D).

RUDOLPH
 ARCHITECTS
 915 Rucker Avenue Everett, Washington
 206 226-5588

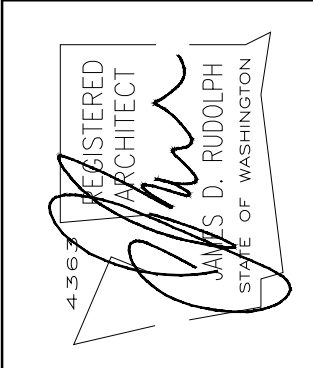

PERMIT SET 03/11/24
 REVISION 02/10/24
 REVISION 04/13/25
 REVISION xx/xx/xx

A New Residence For
Teddy and Megan Dann
 3008 70th Avenue S.E., Mercer Island, Washington 98040

GENERAL CONTRACTOR
 XXX XXX XXX
 XXX XXX XXX
 XXX XXX XXX
 License # XXXXXXXXXX

A1

Basement Exemption Calculations

Dann Residence December 12, 2024

Basement Exemption Calculation Mercer Island

Mark	g	Elev.	G Elev.	Elev. y = Reduced Height	H = Wall Height	H Feet =	y = h =	h / H = dp	decimal %	SC Segment Coverage x SL Segment Length	SC %	SL Feet
Mark A	g	292.16	- G Elev. = 292.90	= Elev. y = -0.74	H Feet = 8.9	y = h = 9.64	h / H = dp	1.08	dp x 100 = D = 100.00 %	SC x SL = 38.00	100.00 %	38.00 Feet = 3800.00
Mark B	g	292.16	- G Elev. = 292.90	= Elev. y = -0.74	H Feet = 8.9	y = h = 9.64	h / H = dp	1.08	dp x 100 = D = 100.00 %	SC x SL = 17.13	100.00 %	17.13 Feet = 1713.00
Mark C	g	292.16	- G Elev. = 292.90	= Elev. y = -0.74	H Feet = 8.9	y = h = 9.64	h / H = dp	1.08	dp x 100 = D = 100.00 %	SC x SL = 8.66	100.00 %	8.66 Feet = 866.00
Mark D	g	292.16	- G Elev. = 292.30	= Elev. y = -0.14	H Feet = 8.9	y = h = 9.04	h / H = dp	1.02	dp x 100 = D = 100.00 %	SC x SL = 10.50	100.00 %	10.50 Feet = 1050.00
Mark E	g	292.16	- G Elev. = 292.90	= Elev. y = -0.74	H Feet = 8.9	y = h = 9.64	h / H = dp	1.08	dp x 100 = D = 100.00 %	SC x SL = 8.66	100.00 %	8.66 Feet = 866.00
Mark F	g	292.16	- G Elev. = 292.90	= Elev. y = -0.74	H Feet = 8.9	y = h = 9.64	h / H = dp	1.08	dp x 100 = D = 100.00 %	SC x SL = 12.29	100.00 %	12.29 Feet = 1229.00
Mark G	g	292.16	- G Elev. = 292.75	= Elev. y = -0.59	H Feet = 8.9	y = h = 9.49	h / H = dp	1.07	dp x 100 = D = 106.63 %	SC x SL = 19.29	106.63 %	19.29 Feet = 2056.88
Mark H	g	292.16	- G Elev. = 290.50	= Elev. y = 1.66	H Feet = 8.9	y = h = 7.24	h / H = dp	0.81	dp x 100 = D = 81.35 %	SC x SL = 1.50	81.35 %	1.50 Feet = 122.02
Mark I	g	292.16	- G Elev. = 291.00	= Elev. y = 1.16	H Feet = 8.9	y = h = 7.74	h / H = dp	0.87	dp x 100 = D = 86.97 %	SC x SL = 10.00	86.97 %	10.00 Feet = 869.66
Mark J	g	292.16	- G Elev. = 291.00	= Elev. y = 1.16	H Feet = 8.9	y = h = 7.74	h / H = dp	0.87	dp x 100 = D = 100.00 %	SC x SL = 1.50	100.00 %	1.50 Feet = 150.00
Mark K	g	292.16	- G Elev. = 291.75	= Elev. y = 0.41	H Feet = 8.9	y = h = 8.49	h / H = dp	0.95	dp x 100 = D = 95.39 %	SC x SL = 3.70	95.39 %	3.70 Feet = 352.96
Mark L	g	292.16	- G Elev. = 290.00	= Elev. y = 2.16	H Feet = 8.9	y = h = 6.74	h / H = dp	0.76	dp x 100 = D = 75.73 %	SC x SL = 18.00	75.73 %	18.00 Feet = 1363.15
Mark M	g	292.16	- G Elev. = 292.75	= Elev. y = -0.59	H Feet = 8.9	y = h = 9.49	h / H = dp	1.07	dp x 100 = D = 100.00 %	SC x SL = 5.00	100.00 %	5.00 Feet = 500.00
Mark N	g	292.16	- G Elev. = 283.75	= Elev. y = 8.41	H Feet = 8.9	y = h = 0.49	h / H = dp	0.06	dp x 100 = D = 5.51 %	SC x SL = 21.88	5.51 %	21.88 Feet = 141.25
											176.11	15079.91

Total Basement Area = 1465.50 S.F. = Sum of (SC Segment Coverage x SL Segment Length)
 Exempted Basement Area = 15079.91 = Sum of (Wall Segment)
 Exempted Basement Area = 1465.50 Sq.Ft. - 1254.88 = 210.62 GFA Basement
 Basement GFA Exempted Net Basement GFA

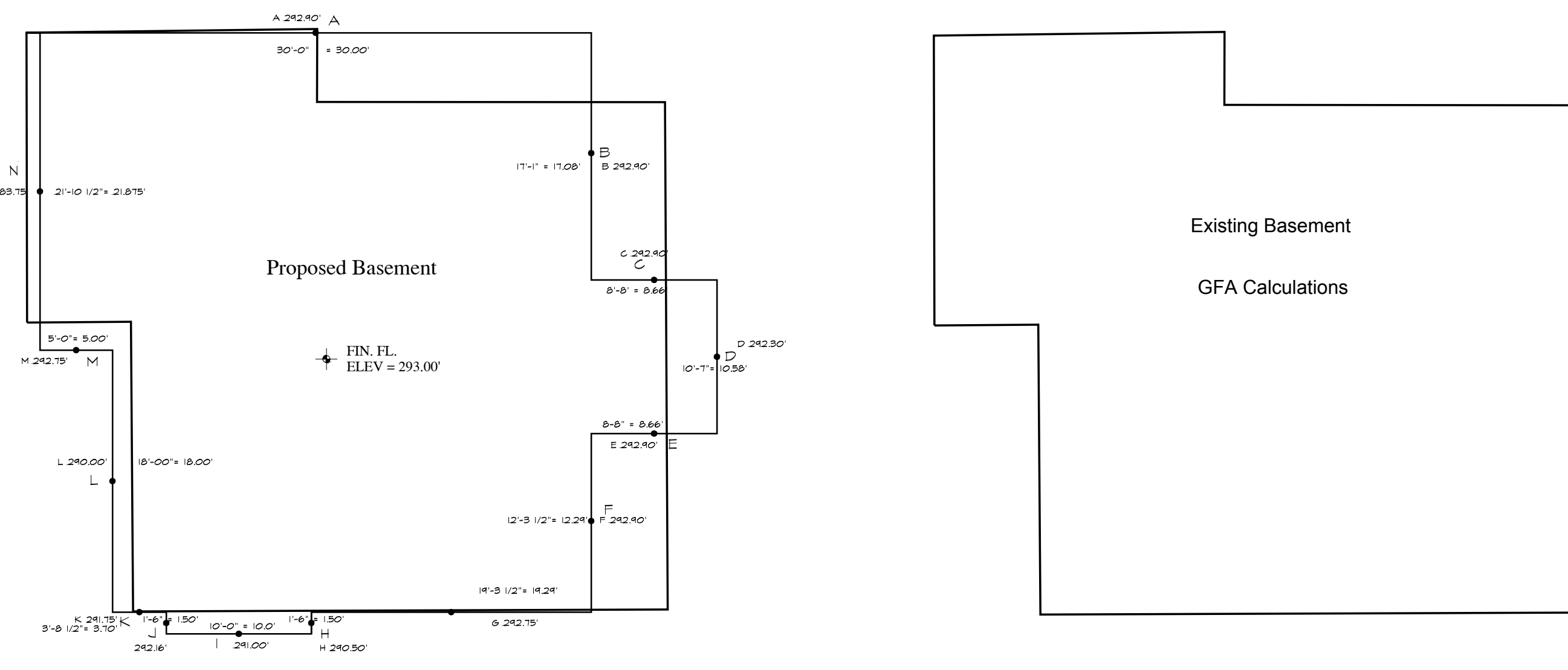

(G.F.A.) = 1,465.50' - 1254.88' = 210.62' GROSS FLOOR AREA

Gross Floor Area Calculations

GROSS FLOOR AREA CALC. MUST BE LESS THAN 45% OF PROP AREA OF LOT 5471.00 x .45% FLOOR AREA TOTAL: 45% ALLOWED 243.20

Category	Area (SQ. FT.)	Notes
UPPER FLOOR AREA:	1,099.00	GROSS
MAIN FLOOR AREA:	1,483.75	GROSS
EXCLUDED STAIR AREA:	-106.50	EXCLUDED
MAIN FLOOR AREA NET F.A.R.:	1,377.25	MAIN LESS STAIR NET
BASEMENT FLOOR AREA:	1,465.50	GROSS
EXCLUDED BASEMENT AREA:	-1,254.88	EXCLUDED
BASEMENT FLOOR AREA NET F.A.R.:	210.62	BASEMENT NET
TOTAL COMBINED FLOOR AREAS:	4,048.25	GROSS
TOTAL COMBINED FLOOR AREA NET F.A.R.:	2,666.87	F.A.R.
F.A.R. CALCULATION FLOOR AREA RATIO:	44.99	% ACTUAL

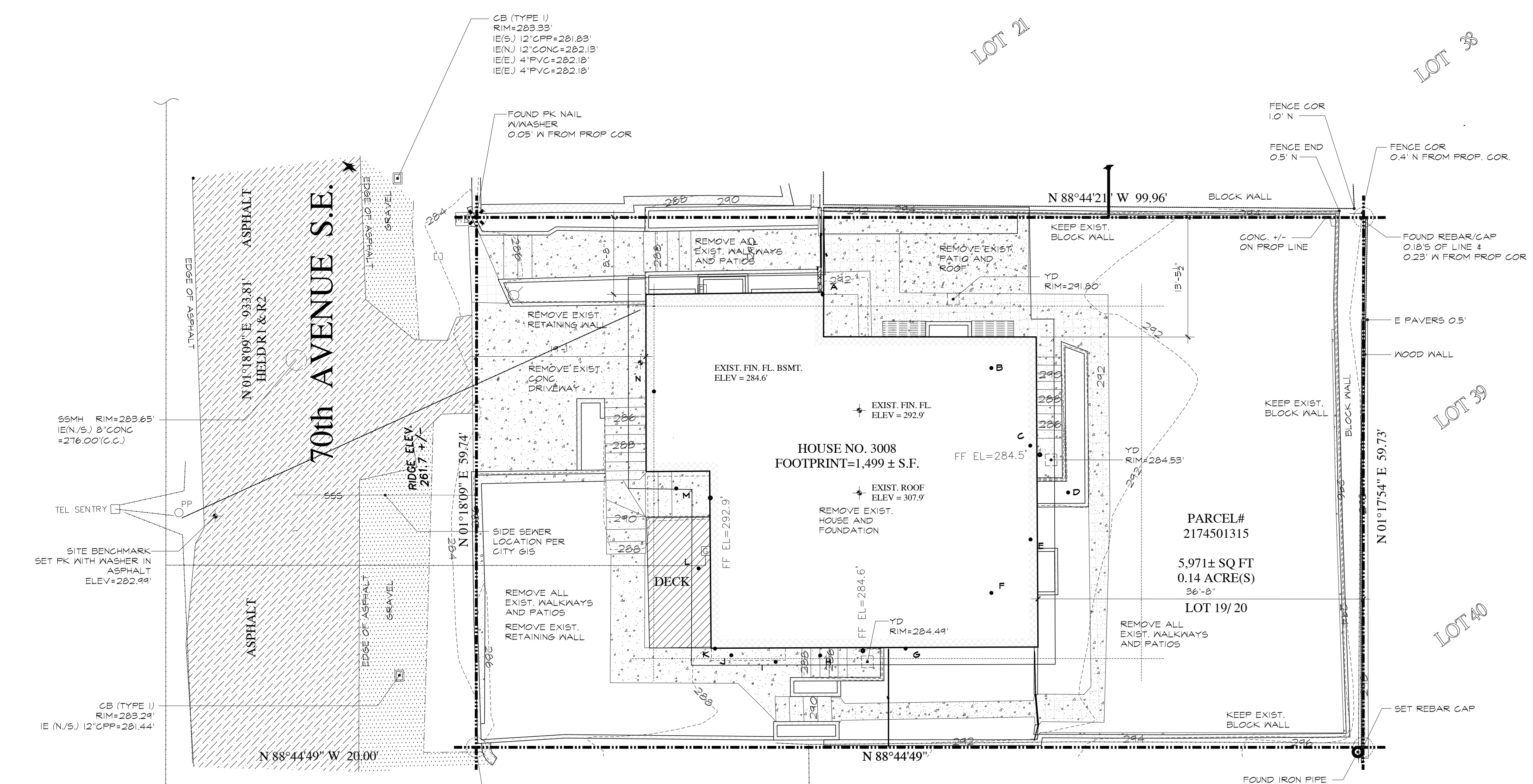

Demolition Plan

SCALE: 1/8" = 1'-0"

RUDOLPH
ARCHITECTS
915 Rucker Avenue Everett, Washington
206 226-5588

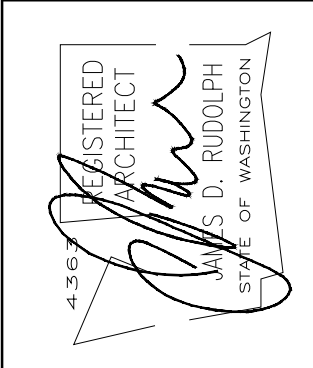

PERMIT SET 03/11/24
 REVISION 02/10/24
 REVISION 04/13/25
 REVISION xx/xx/xx

A New Residence For
Teddy and Megan Dann
 3008 70th Avenue S.E. Mercer Island Washington 98040

OWNER CERTIFICATE
 XXX XXX XXX
 XXX XXX XXX
 License # XXXXXXXX

A2

1483.75 SQ.FT. Main Floor
 106.50 SQ.FT. Stair Exempt
 1377.25 SQ.FT. Total Main Floor Proposed
 1099.50 SQ.FT. Upper Floor
 1465.50 SQ.FT. Total Basement
 1254.88 SQ.FT. Exempt Basement
 210.62 SQ.FT. Basement Net
 2686.88 SQ.FT. Total FAR Actual
 2686.95 SQ.FT. Total FAR Allowed
 - 0.07 SQ.FT. Under FAR Allowed

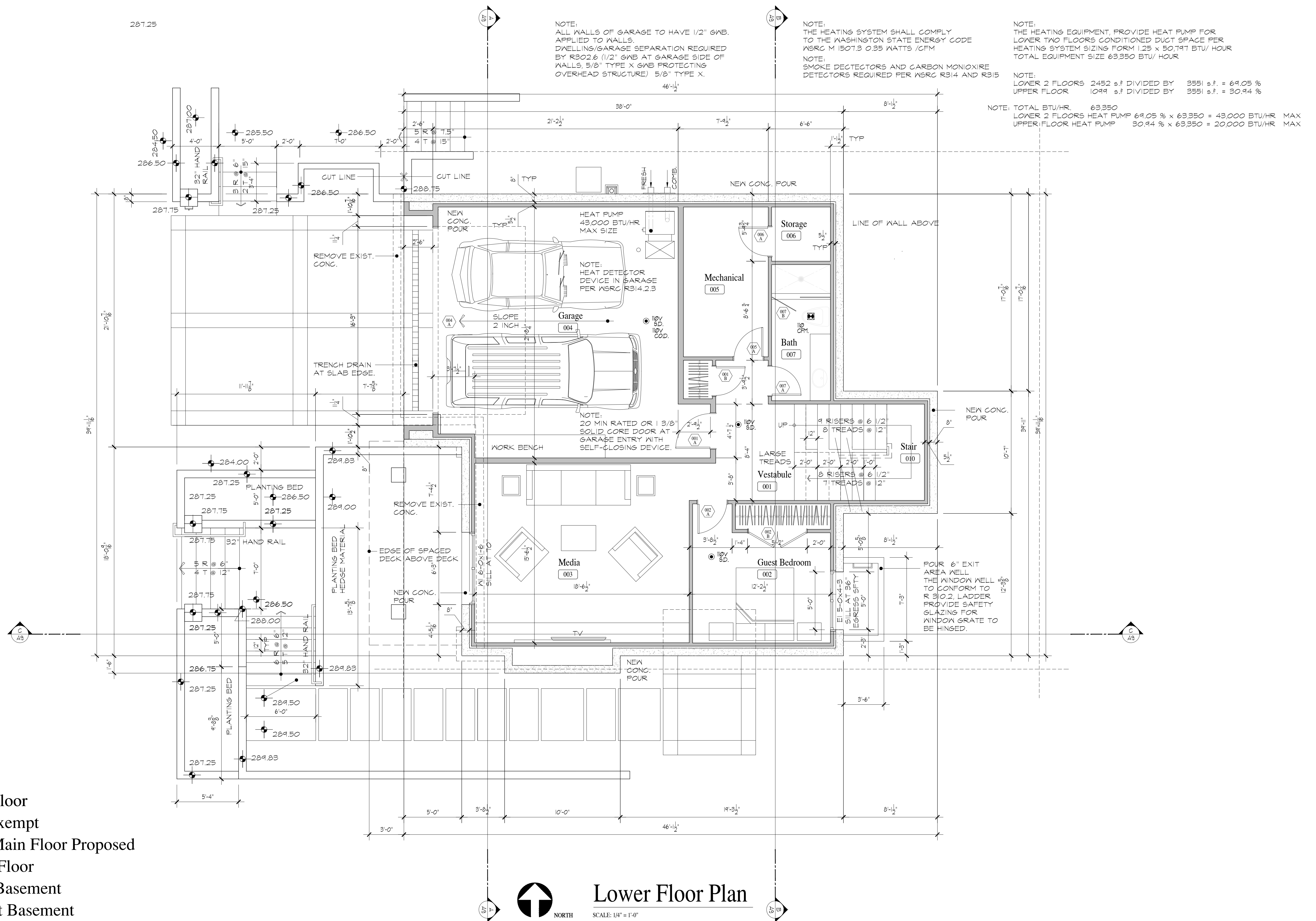

Lower Floor Plan

SCALE: 1/4" = 1'-0"

A New Residence For

Teddy and Megan Dann

3008 70th Avenue S.E., Mercer Island Washington 98040

RUDOLPH ARCHITECTS

915 Rucker Avenue Everett, Washington 206 226-5588

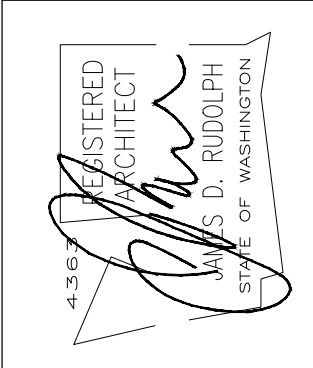

PERMIT SET 03/11/24
 REVISION 02/10/24
 REVISION 04/13/25
 REVISION xx/xx/xx

GREATEST COURTESY
 XXX XXX XXX
 XXX XXX XXX
 XXX XXX XXX
 License # XXXXXXXXXX

A3

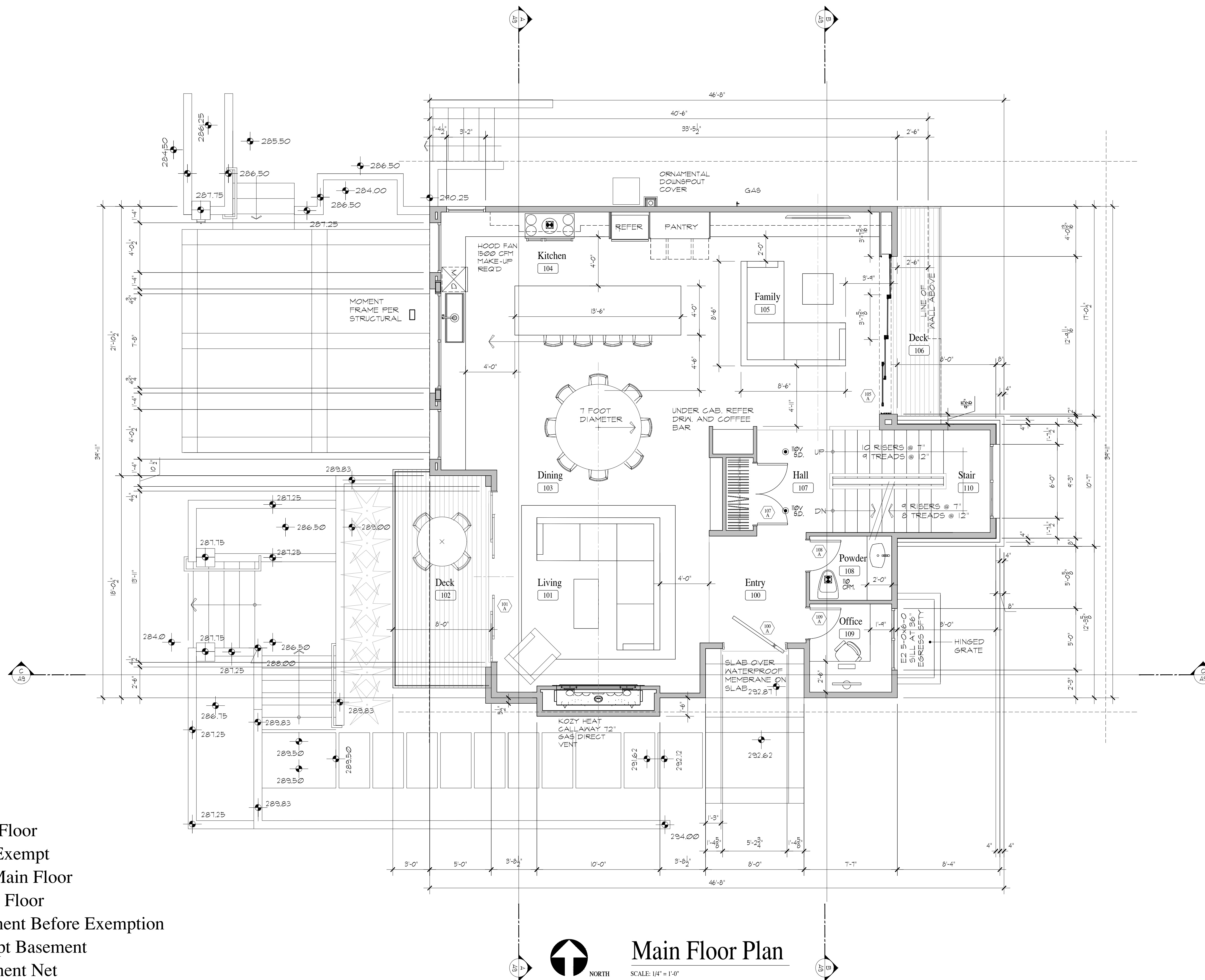

1483.75	SQ.FT.	Main Floor
106.50	SQ.FT.	Stair Exempt
1377.25	SQ.FT.	Net. Main Floor
1099.50	SQ.FT.	Upper Floor
1465.50	SQ.FT.	Basement Before Exemption
1254.88	SQ.FT.	Exempt Basement
210.62	SQ.FT.	Basement Net
2686.87	SQ.FT.	Total FAR Actual
2686.95	SQ.FT.	Total FAR Allowed
- 0.07	SQ.FT.	Under FAR Allowed

Main Floor Plan
 SCALE: 1/4" = 1'-0"

RUDOLPH
ARCHITECTS
915 Rucker Avenue Everett, Washington
206 226-5588

PERMIT SET 03/11/24
REVISION 02/10/24
REVISION 04/13/25
REVISION xx/xx/xx

A New Residence For

Teddy and Megan Dann

3008 70th Avenue S.E. Mercer Island Washington 98040

GENERAL CONTRACTOR
XXX XXX XXX
XXX XXX XXX WW XXXX
(000) XXX-XXX-XXXX
License # XXXXXXXXXX

A4

993.00 SQ.FT. Upper Floor
 106.50 SQ.FT. Stair
 1099.50 SQ.FT. Total Upper Floor

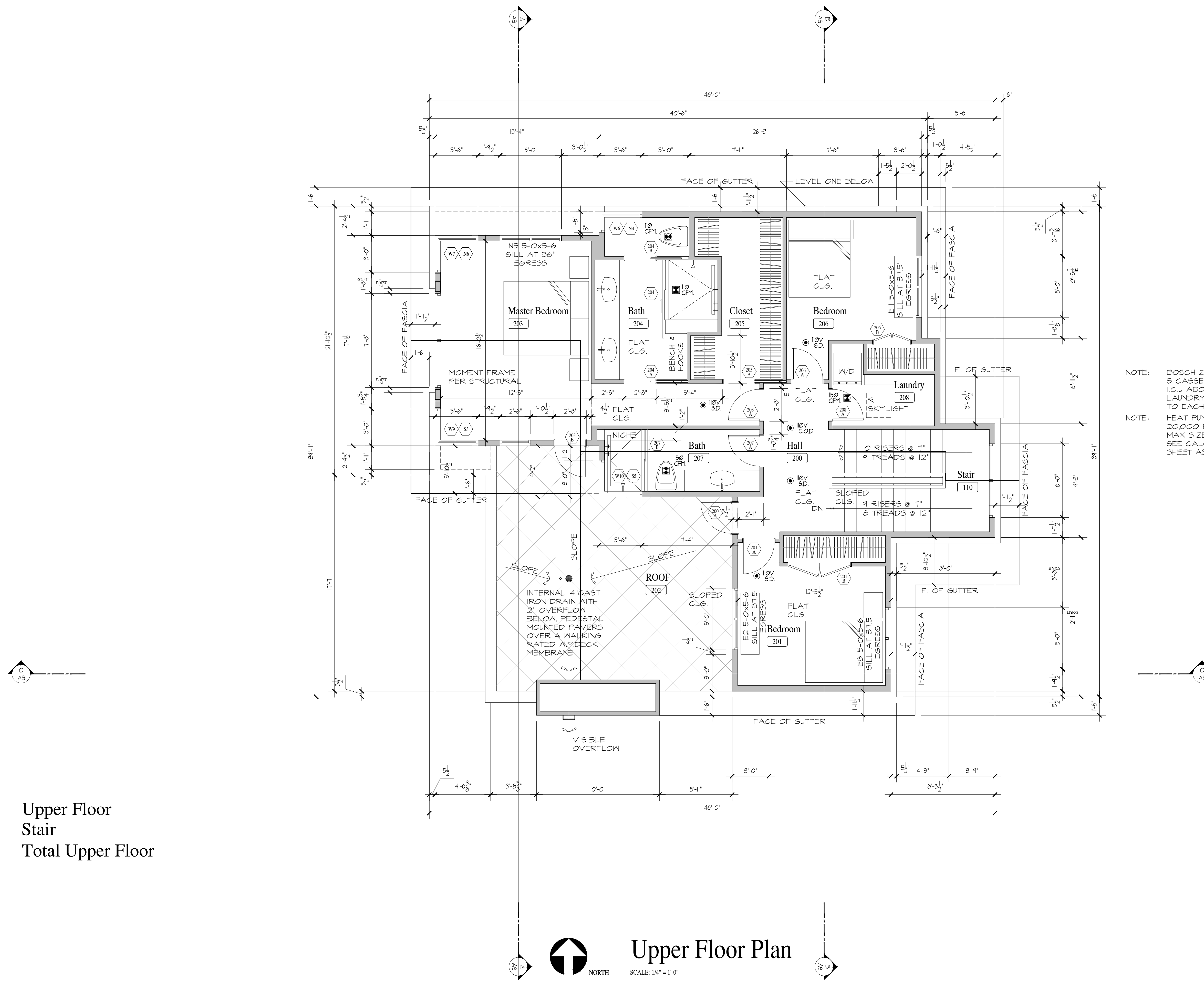

Upper Floor Plan
 SCALE: 1/4" = 1'-0"

NOTE: BOSCH ZONED 3 CASSETTS I.G.U ABOVE LAUNDRY DUCTED TO EACH BEDROOM
 NOTE: HEAT PUMP 20000 BTU/HR MAX SIZE SEE CALC. NOTE ON SHEET A3

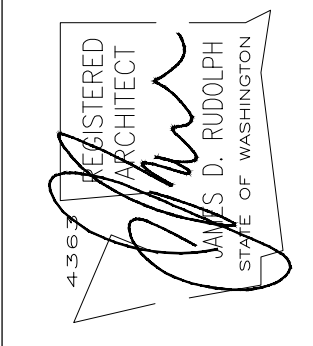

PERMIT SET 03/11/24
 REVISION 02/10/24
 REVISION 04/13/25
 REVISION xx/xx/xx

A New Residence For
Teddy and Megan Dann
 3008 70th Avenue S.E. Mercer Island Washington 98040

GENERAL CONTRACTOR
 XXX XXX XXX
 XXX XXX XXX XX WW XXXX
 (XXX) XXX XXX
 License # XXXXXXXXXX

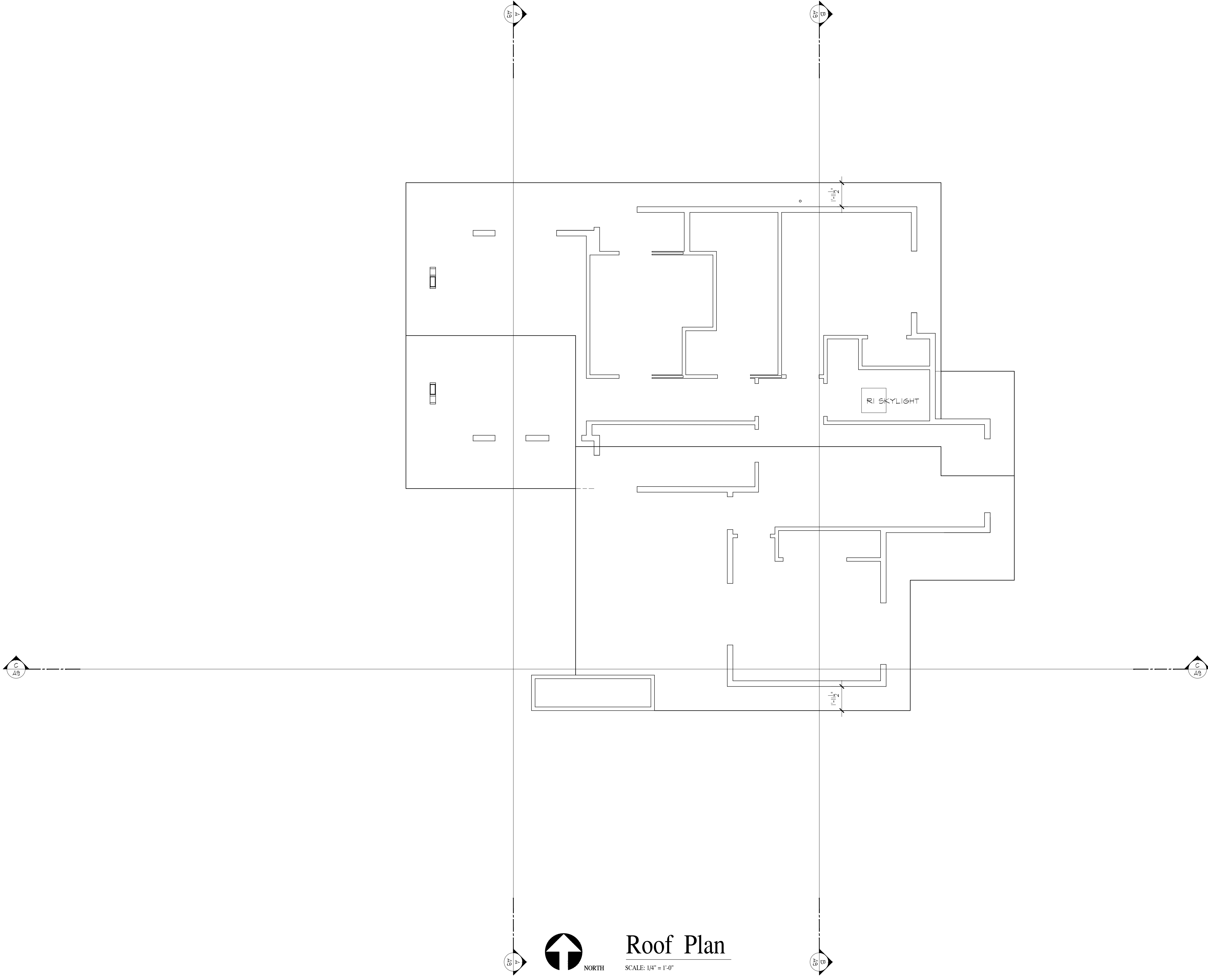

Roof Plan

SCALE: 1/4" = 1'-0"

GENERAL CONTRACTOR
 XXX XXX XXX
 XXX XXX XXX WW XXXX
 (XXX) XXX-XXXX
 License # XXXXXXXXXX

A6

PERMIT SET	03/11/24
REVISION	02/10/24
REVISION	04/13/25
REVISION	xx/xx/xx

A New Residence For
Teddy and Megan Dann
 3008 70th Avenue S.E., Mercer Island Washington 98040

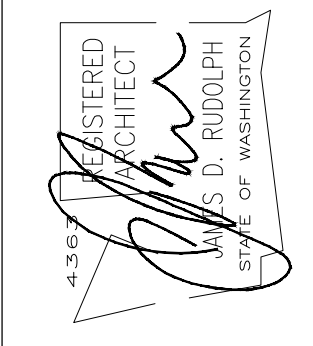

RUDOLPH
 ARCHITECTS
 915 Rucker Avenue Everett, Washington
 206 226-5588

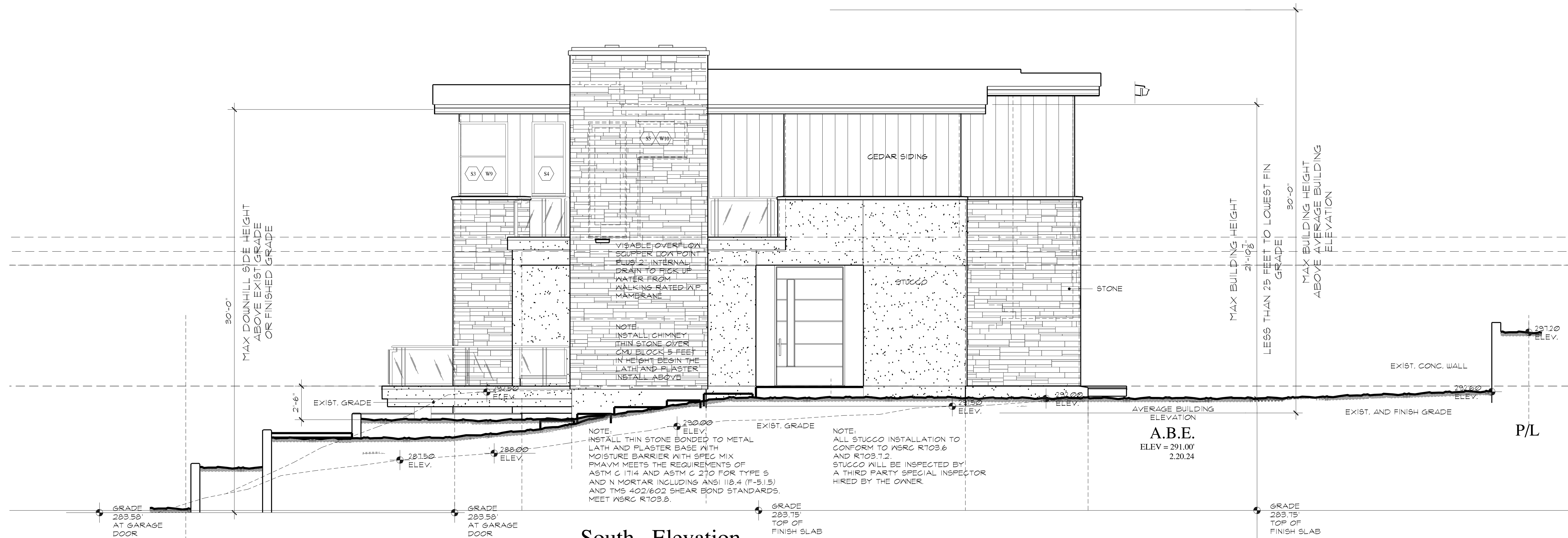

South Elevation

SCALE: 1/4" = 1'-0"

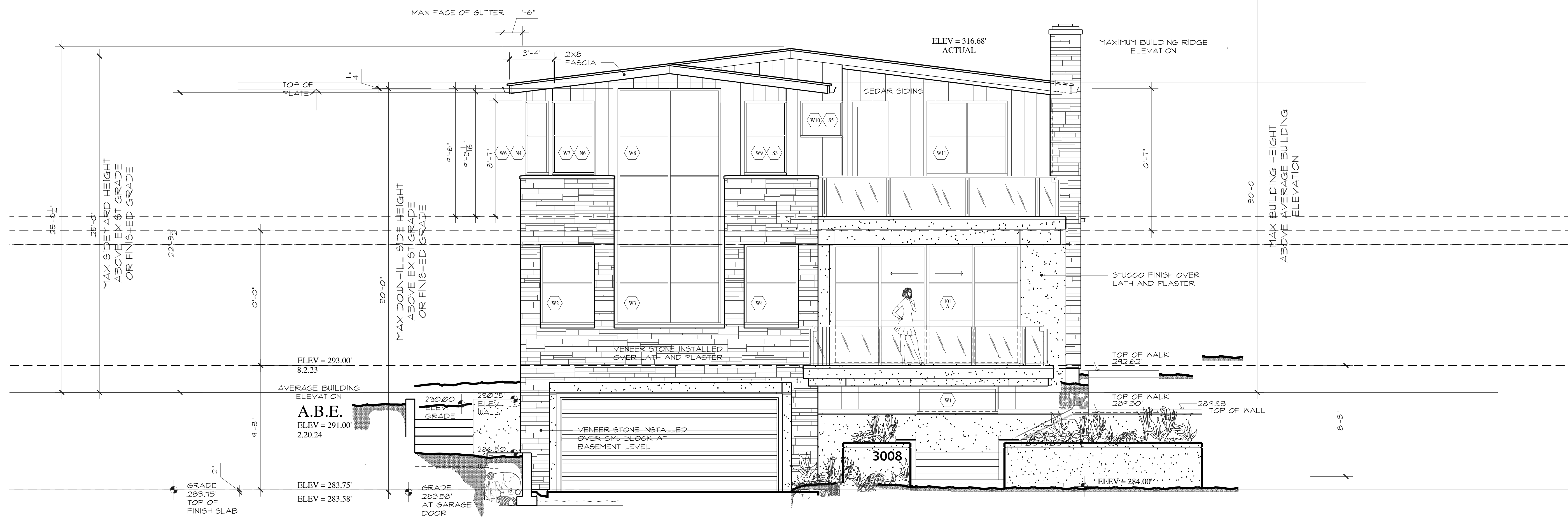

West Elevation

SCALE: 1/4" = 1'-0"

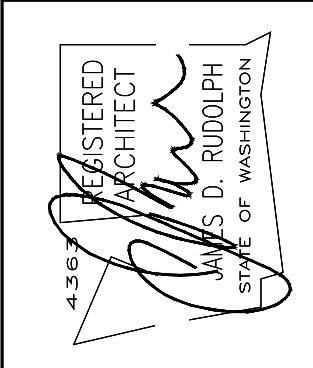

PERMIT SET	03/11/24
REVISION	02/10/24
REVISION	04/13/25
REVISION	xx/xx/xx

PROJECT CREDENTIALS
XXX XXX XXX
XXX XXX XXX WW XXXX
000 XXX XXX
License # XXXXXXXXX

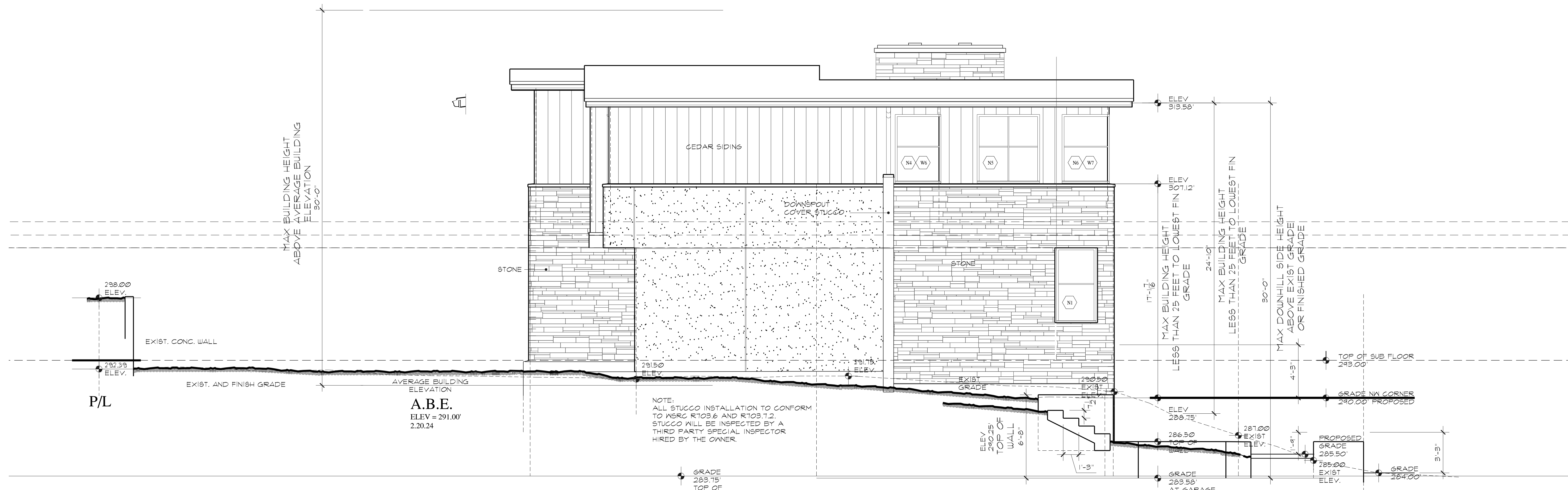

North Elevation

SCALE: 1/4" = 1'-0"

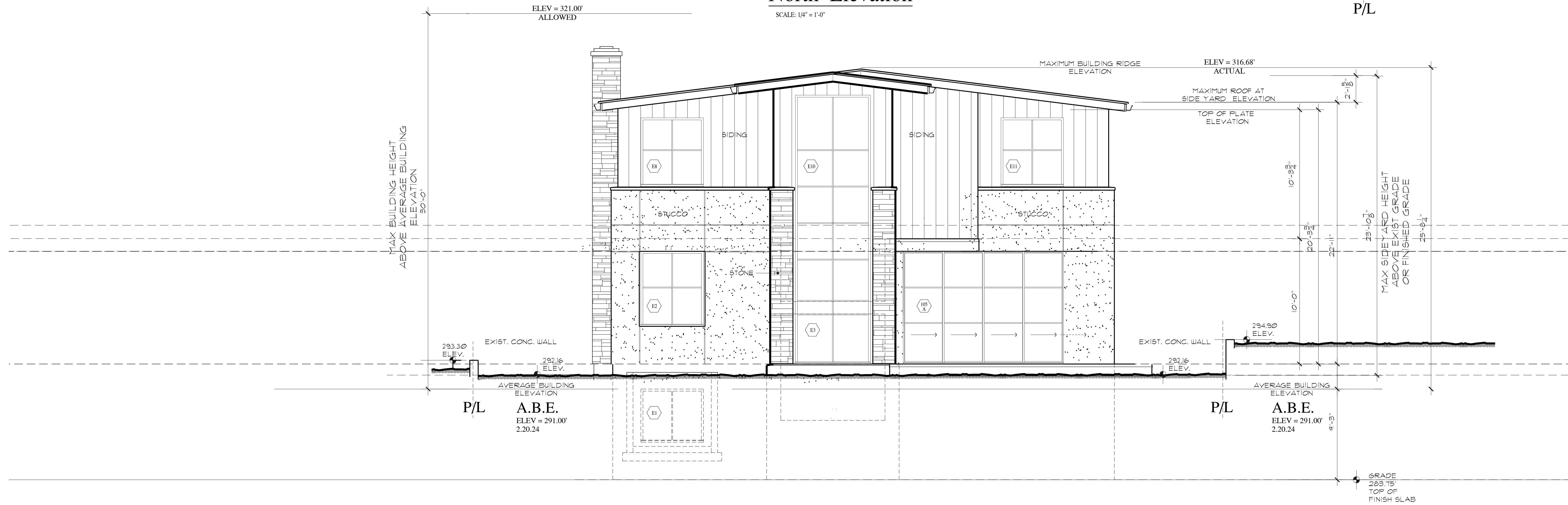

East Elevation

SCALE: 1/4" = 1'-0"

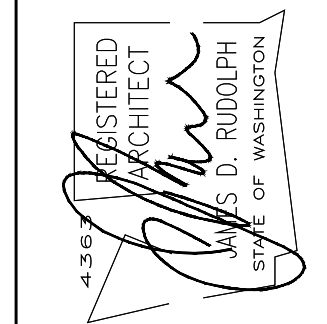

PERMIT SET	03/11/24
REVISION	02/10/24
REVISION	04/13/25
REVISION	xx/xx/xx

GENERAL CONTRACTOR
XXX XXX XXX
XXX XXX XXX
License # XXXXXXXXXX

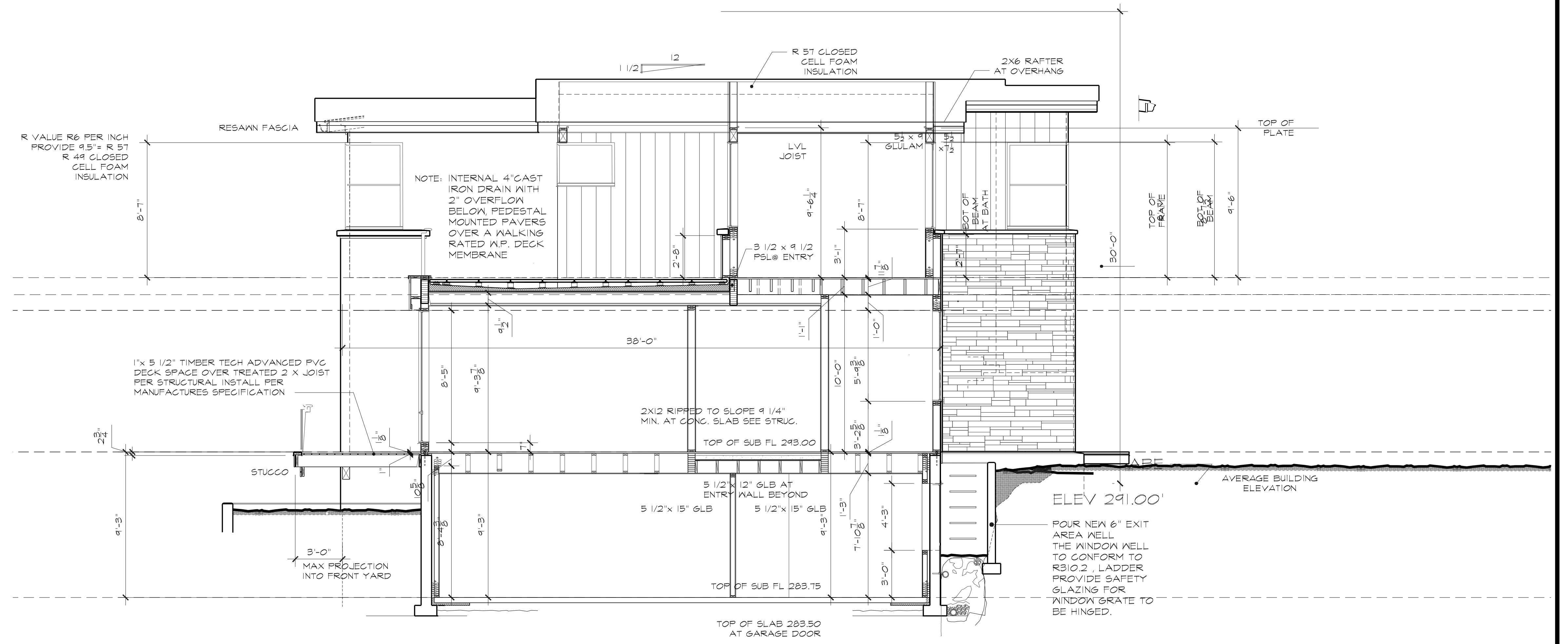

Section C-C
SCALE: 1/4" = 1'-0"

ENERGY CREDIT CALCULATION

SEE 2018 W.S.E.C. PRESCRIPTIVE ENERGY CODE COMPLIANCE SINGLE FAMILY

HEATING OPTION SELECTED	CREDITS
OPTION # 2 HEAT PUMP	1.0 CREDITS
ENERGY OPTIONS SELECTED	
OPTION # 1.4 EFFICIENT BUILDING ENVELOPE	1.0 CREDITS
AIR LEAKAGE CONTROL EFFICIENT VENTILATION	
OPTION # 2.3	1.5 CREDITS
HIGH EFFICIENCY H.V.A.C.	
OPTION # 3.2	1.0 CREDITS
HIGH EFFICIENCY H.V.A.C. DISTRIBUTION SYSTEM	
OPTION # 4.2	1.0 CREDITS
EFFICIENT WATER HEATING	
OPTION # 5.2	0.5 CREDITS
TOTAL CREDITS	6.0 CREDITS

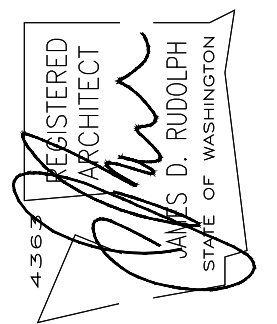

PERMIT SET 03/11/24
REVISION 02/10/24
REVISION 04/13/25
REVISION xx/xx/xx

GENERAL CONTRACTOR
XXX XXX XXX
XXX XXX XXX
Licence # XXXXXXXXXX

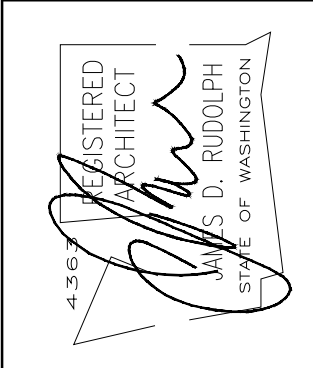
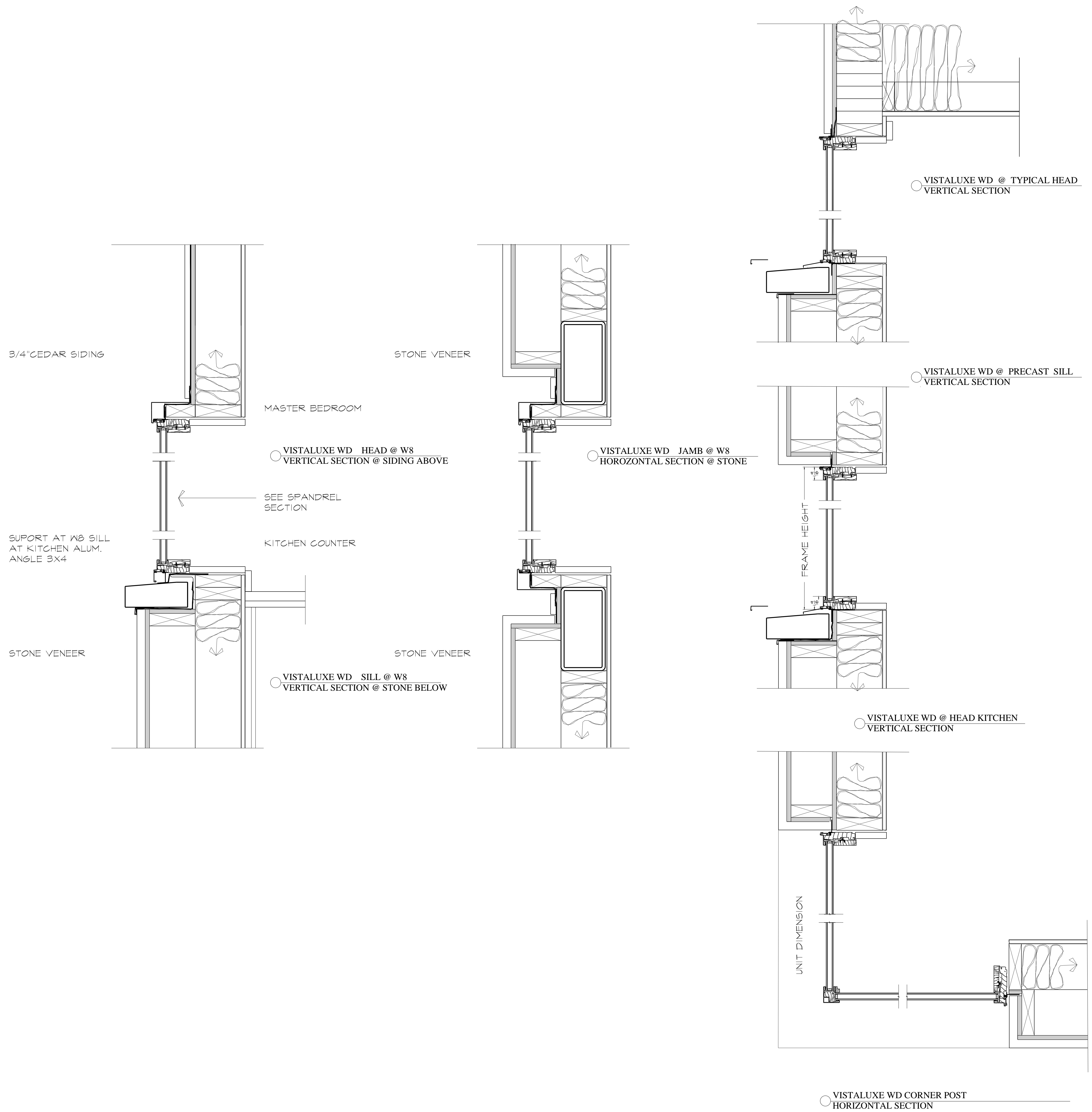

PERMIT SET	03/11/24
REVISION	02/10/24
REVISION	04/13/25
REVISION	xx/xx/xx

A New Residence For
Teddy and Megan Dann
3008 70th Avenue S.E., Mercer Island, Washington 98040

GENERAL CONTRACTOR
XXX XXX XXX
XXX XXX XXX XX WW XXXX
000 XXX-XXX
License # XXXXXXXXXX

3/4" CEDAR SIDING

MASTER BEDROOM
CEILING

VISTALUXE WD HEAD @ W8
VERTICAL SECTION @ SIDING ABOVE

STONE VENEER

PRECAST SILL DETAIL BEYOND
MASTER FLOOR

VISTALUXE WD SILL @ W8
VERTICAL SECTION MASTER FLOOR

R 21 BATT INSUL AT ALL EXTERIOR
WALL LOCATIONS TYP.

2 1/2" SPACE FOR
HORZ. OUTLETS 7" FRAMING HEIGHT
AT SILL TYP.

SPANDREL GLASS
BACK PAINTED IGL
CERAMIC FLOOD COAT
ON #4 SURFACE

MOMENT FRAME PER
STRUCTURAL
JOIST HANGER

SUPPORT WINDOW
FRAMING JAMBS W/CLIPS
AT 16" ON CENTER
TOP AND BOTTOM

DOWN FRAMING @ KIT. CEILING

VISTALUXE WD HEAD @ W8 SPANDREL
VERTICAL SECTION KITCHEN

R 21 BATT INSUL AT ALL EXTERIOR
WALL LOCATIONS TYP.

SUPPORT AT W8 SILL
AT KITCHEN ALUM.
ANGLE 3x4

PRECAST SILL

STONE VENEER

VISTALUXE WD SILL @ PRECAST @ W8
VERTICAL SECTION KITCHEN COUNTER

VISTALUXE WD @ MASTER HEAD
VERTICAL SECTION

PRECAST SILL DETAIL

VISTALUXE WD @ MASTER SILL
VERTICAL SECTION

VISTALUXE WD @ MASTER FLOOR SILL
VERTICAL SECTION

R 21 BATT INSUL AT ALL EXTERIOR
WALL LOCATIONS TYP.

MOMENT FRAME PER
STRUCTURAL
JOIST HANGER

DOWN FRAMING @ KIT. CEILING

VISTALUXE WD @ SPANDREL
VERTICAL SECTION

R 21 BATT INSUL AT ALL EXTERIOR
WALL LOCATIONS TYP.

VISTALUXE WD @ TYP.SILL
VERTICAL SECTION

RUDOLPH
ARCHITECTS
915 Rucker Avenue Everett, Washington
206 226-5588

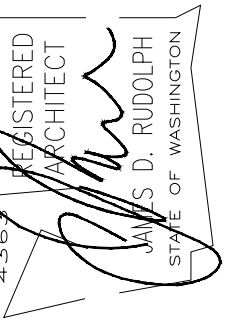

PERMIT SET 03/11/24
REVISION 02/10/24
REVISION 04/13/25
REVISION xx/xx/xx

A New Residence For
Teddy and Megan Dann
3008 70th Avenue S.E., Mercer Island, Washington 98040

GENERAL CONTRACTOR
XXX XXX XXX
XXX XXX XXX
XXX XXX XXX XX WW XXXX
000 XXX-XXX
License # XXXXXXXXXX

A12

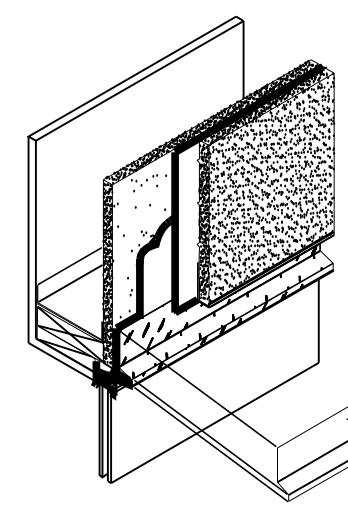

SHEATHING
WATER RESISTANT BARRIER
SELF-FURRING LATH
CEMENT PLASTER
HEAD FLASHING MEMBRANE
CASING BEAD
HEAD FLASHING (METAL OR PVC)

NOTE: FOR END DAMS REFER TO FWB9
3" (77 mm) MIN.
DEPTH OF CEMENT PLASTER PLUS 1/4" (7 mm)
1/2" (13 mm) MIN.

SLOPE OUTWARD 1/8" (3 mm) MIN.
EXTEND HEAD FLASHING HORIZONTALLY 3/4" (19 mm) MIN. BEYOND WINDOW JAMB EACH SIDE.

(Fabricated From Metal or PVC)

43 Window Head Flashing
SCALE: 3/4" = 1'-0"

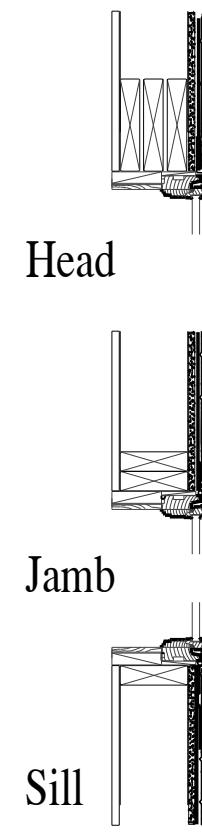

SHEATHING
CEMENT PLASTER
SELF-FURRING LATH
WATER RESISTANT BARRIER, LAP OVER FLANGE OF METAL FLASHING
CASING BEAD
METAL HEAD FLASHING
SEALANT
WOOD WINDOW
CEMENT PLASTER
SELF-FURRING LATH
WATER RESISTANT BARRIER
CASING BEAD
BACKER ROD AND SEALANT
WOOD WINDOW
WOOD WINDOW
BACKER ROD AND SEALANT
CASING BEAD
SELF-FURRING LATH
CEMENT PLASTER
WATER RESISTANT BARRIER

44 Wood Window
SCALE: 3/4" = 1'-0"

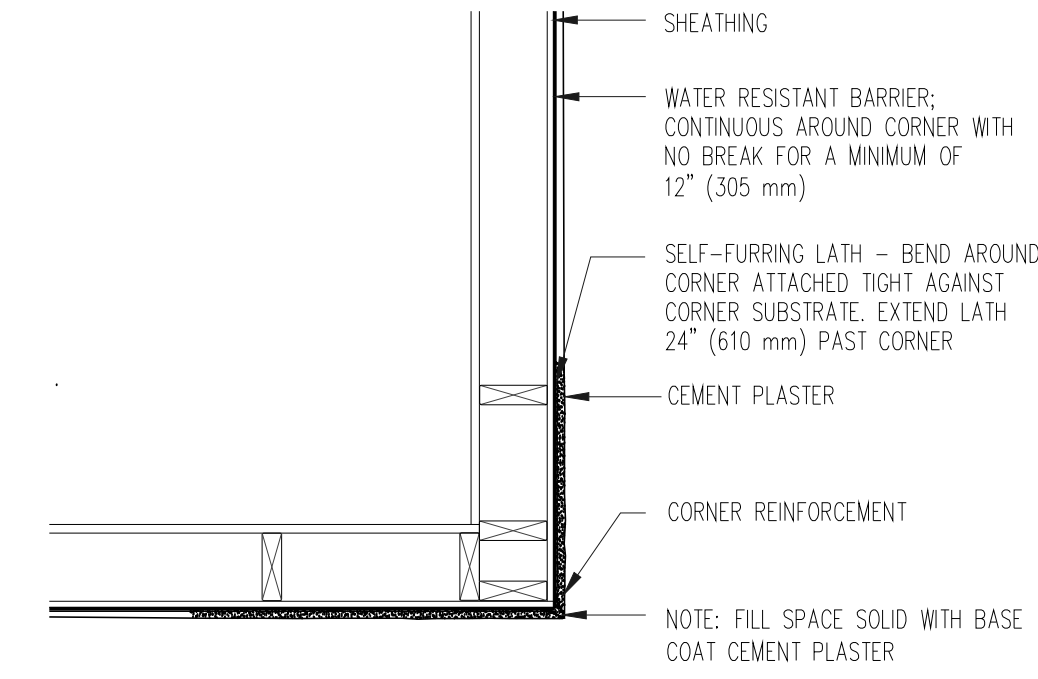

NOTE: FILL SPACE SOLID WITH BASE COAT CEMENT PLASTER
WELDED WIRE WITH PLASTIC NOSE, OR PVC CORNER TRIM IS RECOMMENDED IF FINISH COAT IS A SAND FINISH CEMENT PLASTER OR ACRYLIC FINISH COAT

45 Corner Trim for Fine Finish
SCALE: 3/4" = 1'-0"

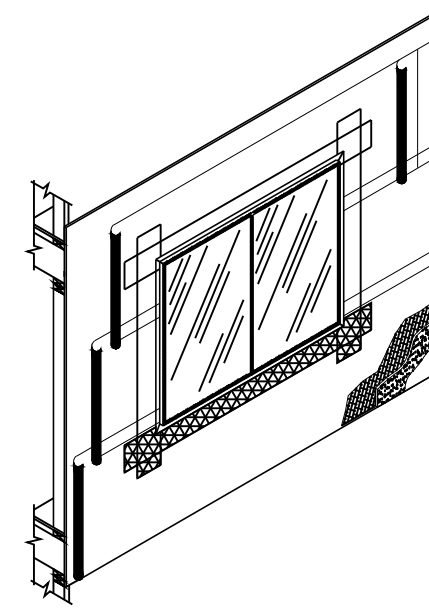

LAP WATER RESISTANT BARRIER VERTICALLY 12" (305 mm)
LAP WATER RESISTANT BARRIER HORIZONTALLY 3" (76 mm) MIN.

SLIP LOWER END OF JAMB FLASHING MEMBRANE AND SILL FLASHING MEMBRANE OVER WATER RESISTANT BARRIER AT THE WINDOW SILL

LATH (SELF FURRED)

FINISH COAT BASECOAT

THIS SHEET OF WATER RESISTANT BARRIER TO SLIP UNDER SILL AND FLASHING MEMBRANE, NOTCH WATER RESISTANT BARRIER TO FIT TIGHTLY AROUND WINDOW FRAME

ONE AND/OR TWO LAYERS OF WATER RESISTANT BARRIER PER BUILDING CODE REQUIREMENTS

48 Flashing Membrane and Water Resistant Barrier Application Sequence
SCALE: 3/4" = 1'-0"

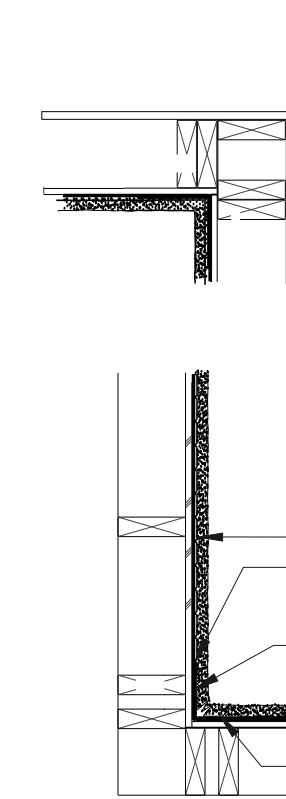

FLASHING MEMBRANE AROUND CORNER, OVER WATER RESISTANT BARRIER, OR TWO LAYERS OF WATER RESISTANT BARRIER
SELF-FURRING LATH, BEND AT INSIDE CORNER, ATTACH TIGHT TO INSIDE CORNER SUBSTRATE. EXTEND MIN. 24" (610 mm) PAST CORNER. DO NOT CUT MEMBRANE WHEN INSTALLING LATH

SHEATHING
CEMENT PLASTER
SELF-FURRING LATH
FLASHING MEMBRANE - OVER WATER RESISTANT BARRIER EXTENDING 8" (203 mm) MIN. OR EACH SIDE
WATER RESISTANT BARRIER CONTINUOUS AROUND CORNER

INSIDE CORNER CONTROL JOINT
NOTE: AN INSIDE CORNER CONTROL JOINT IS NOT A STANDARD RECOMMENDATION WHEN FRAMING AND SUBSTRATE CONSTRUCTION THAT THE STUCCO ASSEMBLY IS ATTACHED TO ARE THE SAME

49 Inside Corner Control Joint
SCALE: 3/4" = 1'-0"

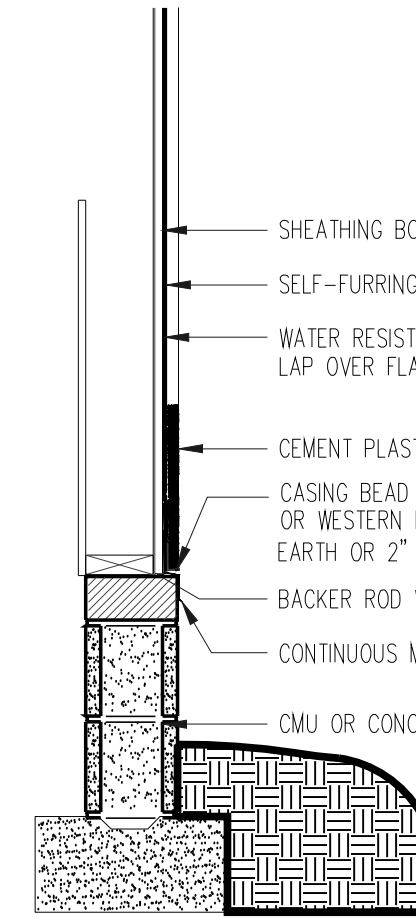

CASING BEAD W/ WEEPS BY AMCO, CEMCO, OR WESTERN PLACED A MINIMUM 4" ABOVE EARTH OR 2" ABOVE PAVED SURFACES.

50 Termination at Foundation
SCALE: 3/4" = 1'-0"

NOTE: FLASHING MEMBRANE TO BE INSTALLED BEHIND FASCIA THAT ADJUTS WALL. WRB TO BE INSTALLED IN "SHINGLE-FASHION" WITH FLASHING MEMBRANE.
FLASHING MEMBRANE
SEALANT (OPTIONAL)
WATER TIGHT DIVERTER SEAMS (TYPICAL)
KICKER FLASH

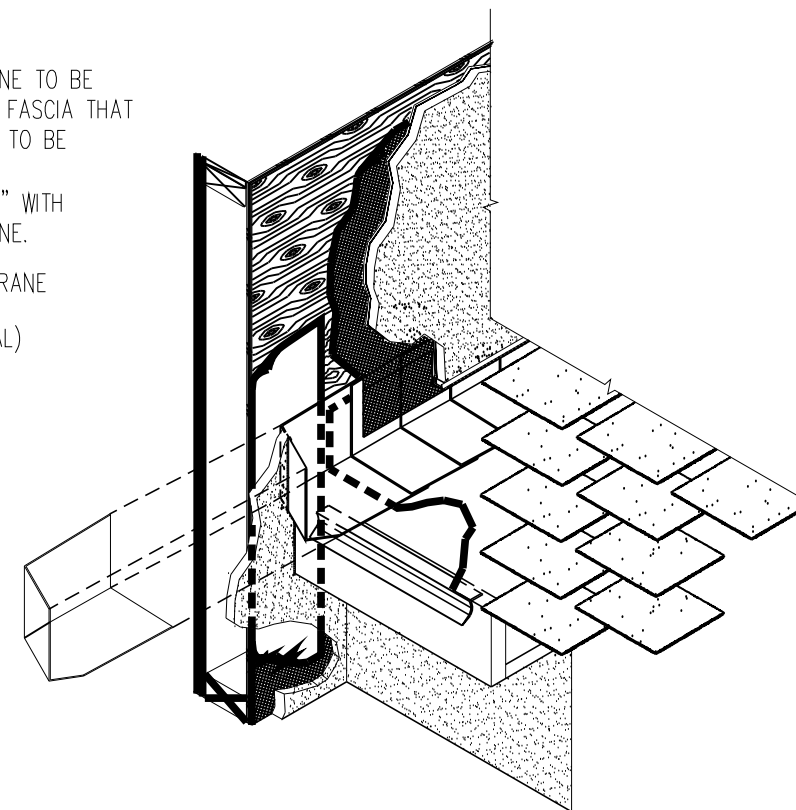

53 Roof/Kicker Flashing Axonometric
SCALE: 3/4" = 1'-0"

WATER RESISTANT BARRIER, LAP OVER METAL FLASHING, BEHIND CASING BEAD
SELF-FURRING LATH OVER CASING BEAD

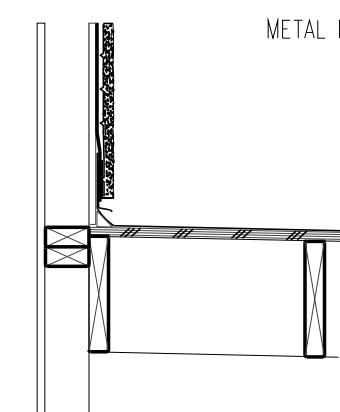

METAL FLASHING, LAP OVER ROOFING MEMBRANE
ROOF DECKING OR DECK SURFACE
MINIMUM 2% SLOPE

54 Counter Flashing at Roofing/Deck Membrane
SCALE: 3/4" = 1'-0"

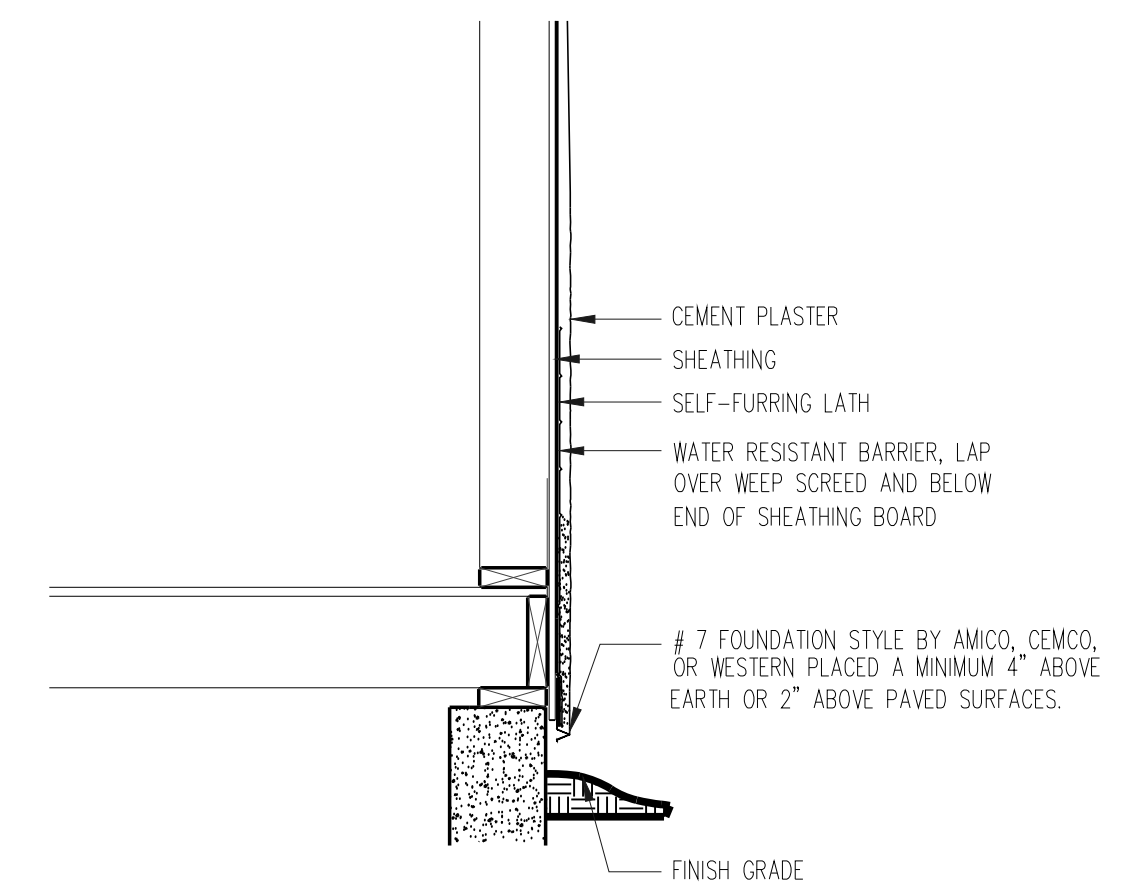

7 FOUNDATION STYLE BY AMCO, CEMCO, OR WESTERN PLACED A MINIMUM 4" ABOVE EARTH OR 2" ABOVE PAVED SURFACES.

55 Termination at Foundation/Finished Grade
SCALE: 3/4" = 1'-0"

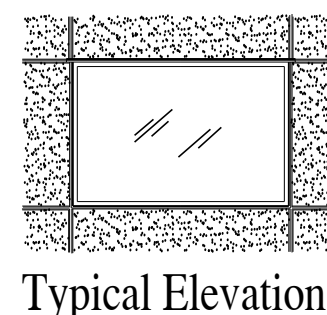

Typical Elevation

NOTE: FLANGES OF CONTROL JOINTS AND/OR OTHER TRIM ACCESSORIES MAY REQUIRE TRIMMING ATTACHMENT FLANGES FOR PROPER FIT INTO CASING BEAD. ALL ACCESSORIES NEED TO FIT TIGHT AND CREATE A UNIFORM DEPTH OF CONTROL JOINTS AND OTHER TRIM.

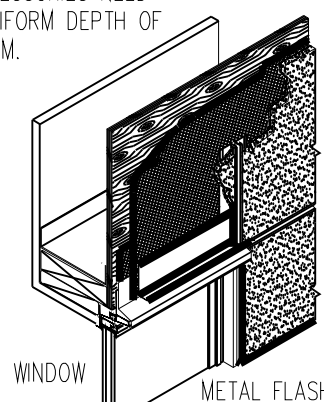

58 Flashing/Control Joint at Window Head
SCALE: 3/4" = 1'-0"

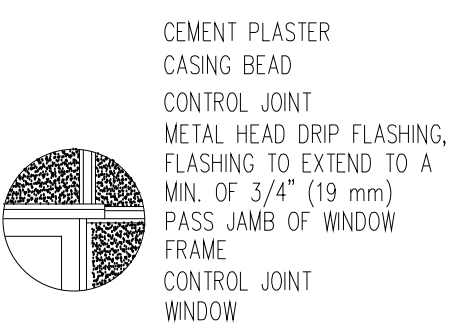

SHEATHING
WATER RESISTANT BARRIER
SELF-FURRING LATH
CEMENT PLASTER

CASING BEADS

3/8" (10 mm) RIB LATH
INSTALL DIRECTLY AGAINST SOFFIT FRAMING 24" (609 mm) O.C.
CEMENT PLASTER

NOTES: FRAMING JOIST SPACED AT 24" (609 mm) REQUIRES 3/8" (10 mm) RIB LATH PERPENDICULAR TO JOINTS. LATH RIBS SHALL BE NESTED.

59 Stucco Soffit/Fascia
SCALE: 3/4" = 1'-0"

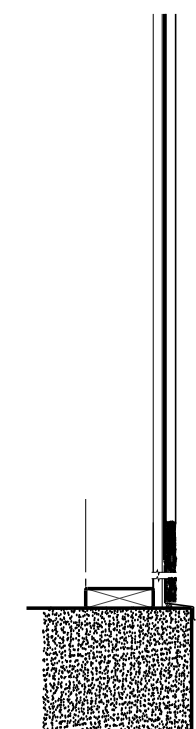

SELF-FURRING LATH
SHEATHING BOARD
WATER RESISTANT BARRIER, LAP OVER FLASHING BEHIND CASING BEAD
CEMENT PLASTER
CASING BEAD (WITH WEEP HOLES)
SEALANT
FLASHING
FOUNDATION WALL

60 Casing Bead at Concrete Foundation
SCALE: 3/4" = 1'-0"

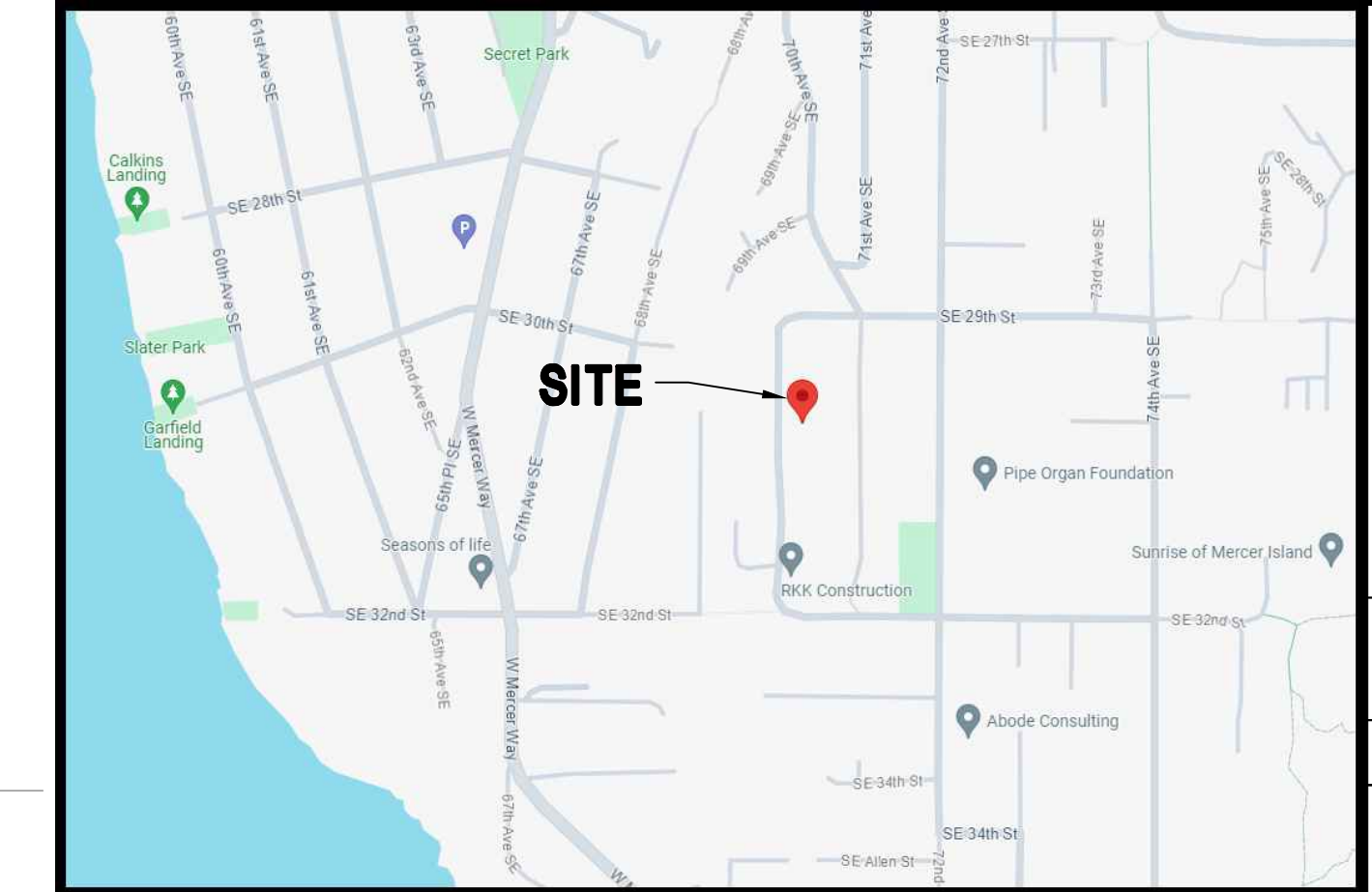
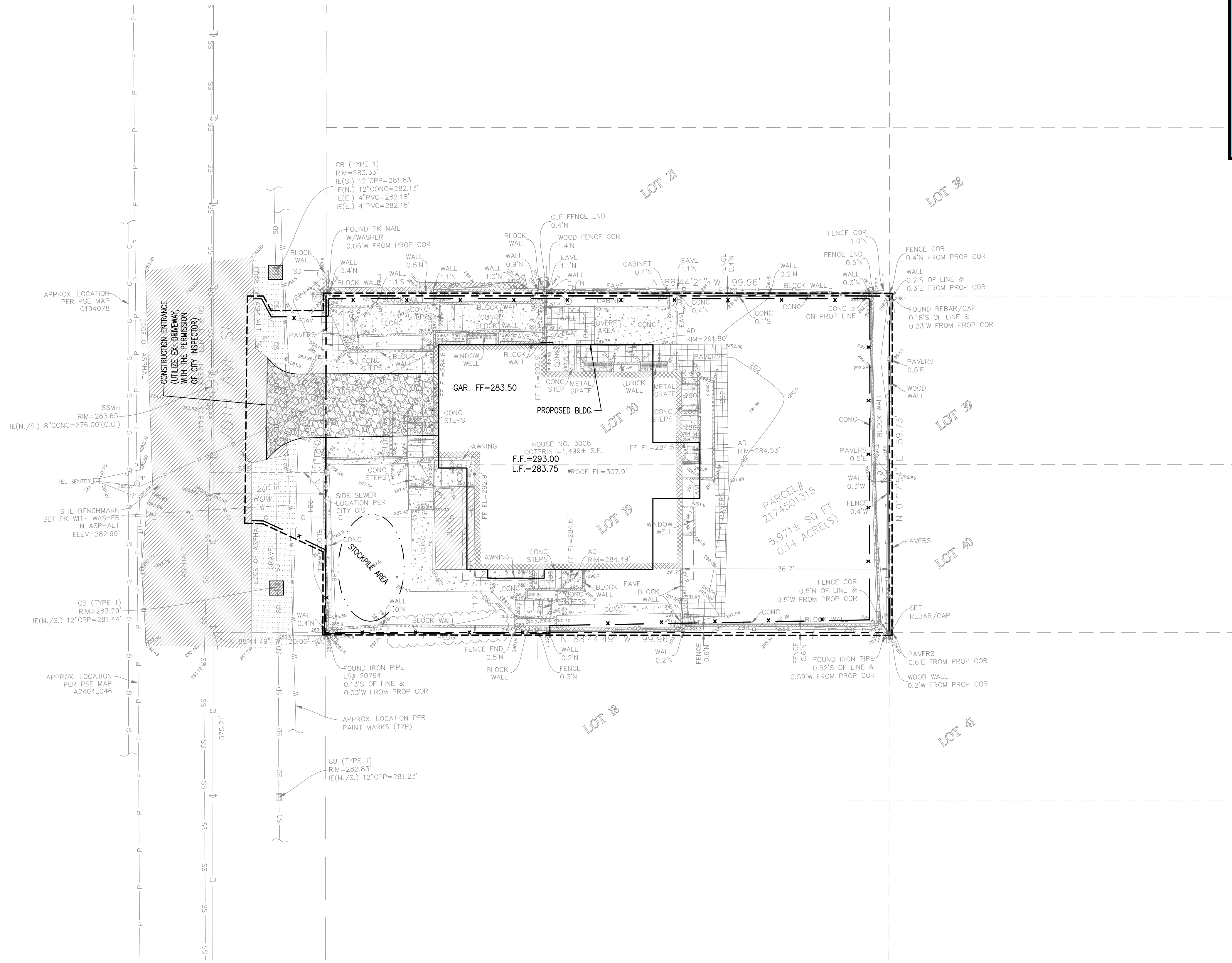

NO.	DATE	REVISION



C2MY
 C2MY ENGINEERS, LLC
 PO BOX 52883
 BELLEVUE, WA 98015
 (206) 922-9376
 cmchin@c2my.com

LEGEND:

- TEMPORARY CONSTRUCTION ENTRANCE (USING EX. ASP. DRWY.)
- SILT FENCE/CLEARING LIMITS
- DISTURBANCE LIMITS
- PROPOSED BUILDING

SURVEY LEGEND:

- | | | | |
|--|---------------------------|--|---------------------------|
| | ASPHALT SURFACE | | NAIL AS NOTED |
| | BENCHMARK | | POWER METER |
| | BUILDING | | POWER (OVERHEAD) |
| | CENTERLINE ROW | | POWER POLE |
| | CONCRETE SURFACE | | REBAR & CAP (SET) |
| | CULVERT PIPE | | REBAR / IRON PIPE (FOUND) |
| | DECK | | RETAINING WALL |
| | FENCE LINE (CHAIN LINK) | | ROCKERY |
| | FENCE LINE (WOOD) | | SEWER LINE |
| | GAS LINE | | SEWER MANHOLE |
| | GAS METER | | STORM DRAIN LINE |
| | GRAVEL SURFACE | | TELEPHONE (OVERHEAD) |
| | HEDGE FOLIAGE LINE | | TREE (AS NOTED) |
| | INLET (TYPE 1) | | WATER LINE |
| | INLET (TYPE 2) | | WATER METER |
| | MONUMENT (IN CASE, FOUND) | | WATER VALVE |

LEGAL DESCRIPTION

(PER STATUTORY WARRANTY DEED RECORDING# 20211206001056)
 LOTS 19 AND 20, BLOCK 7, EAST SEATTLE, ACCORDING TO THE PLAT THEREOF RECORDED IN VOLUME 3 OF PLATS, PAGE 22, RECORDS OF KING COUNTY, WASHINGTON.
 SITUATE IN THE COUNTY OF KING, STATE OF WASHINGTON.

BENCHMARK AND DATUM PER SURVEY

NAD 83(2011) WASHINGTON NORTH STATE PLANE
 COORDINATES PER GPS OBSERVATIONS
 NAVD 88 PER GPS OBSERVATIONS

EARTHWORK QUANTITIES:

CUT = 70 CY.
 FILL = 50 CY.

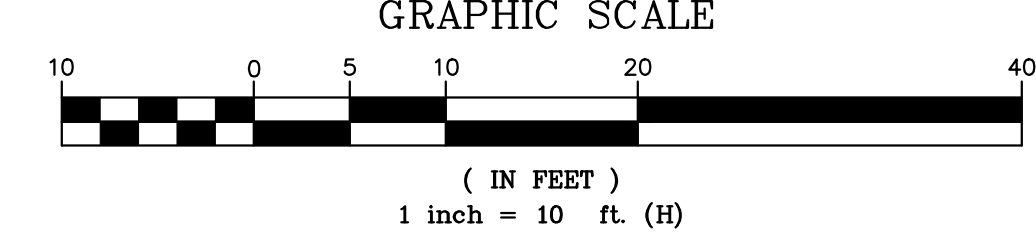

DATE:
 09-11-24

PROJECT: DANN RESIDENCE
 3008 10TH AVENUE SE
 MERCER ISLAND, WA 98040

TESC PLAN

FILE NO:
 2405
 DWS

SHEET
 C1.0

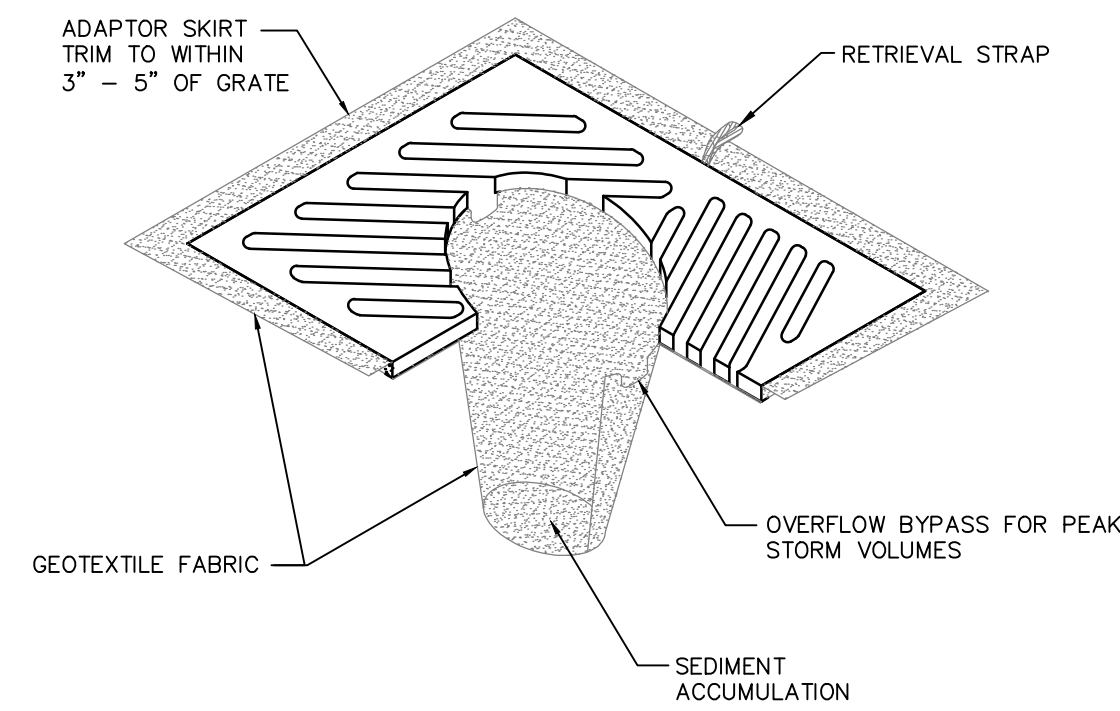

- NOTES**
1. INSERT SHALL BE INSTALLED PRIOR TO CLEARING AND GRADING ACTIVITY, OR UPON PLACEMENT OF A NEW CATCH BASIN.
 2. SEDIMENT SHALL BE REMOVED FROM THE UNIT WHEN IT BECOMES HALF FULL .
 3. SEDIMENT REMOVAL SHALL BE ACCOMPLISHED BY REMOVING THE INSERT, EMPTYING, AND RE-INSERTING IT INTO THE CATCH BASIN.

CATCH BASIN INLET PROTECTION INSERT
NTS

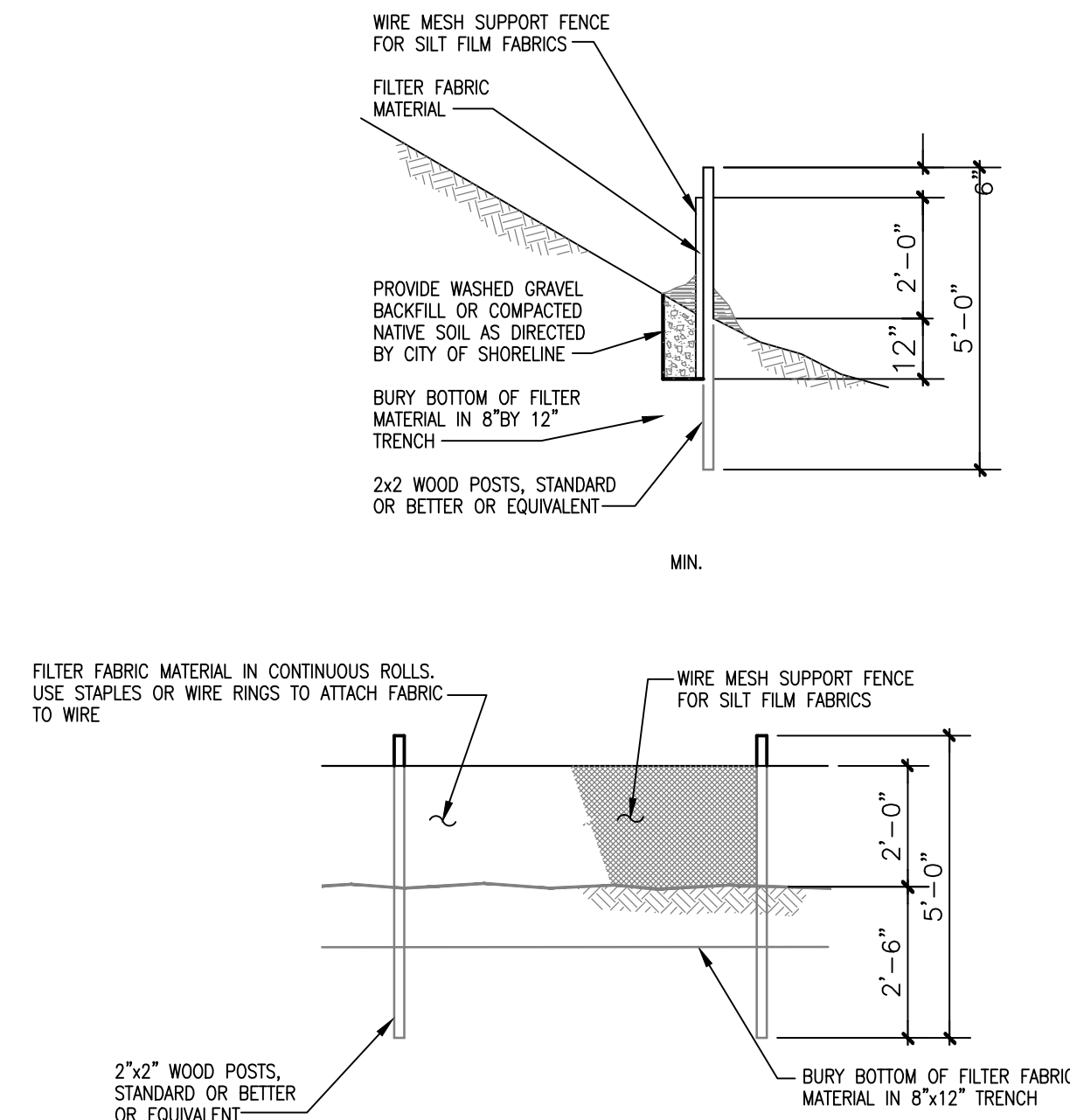

SILT FENCE
NO SCALE

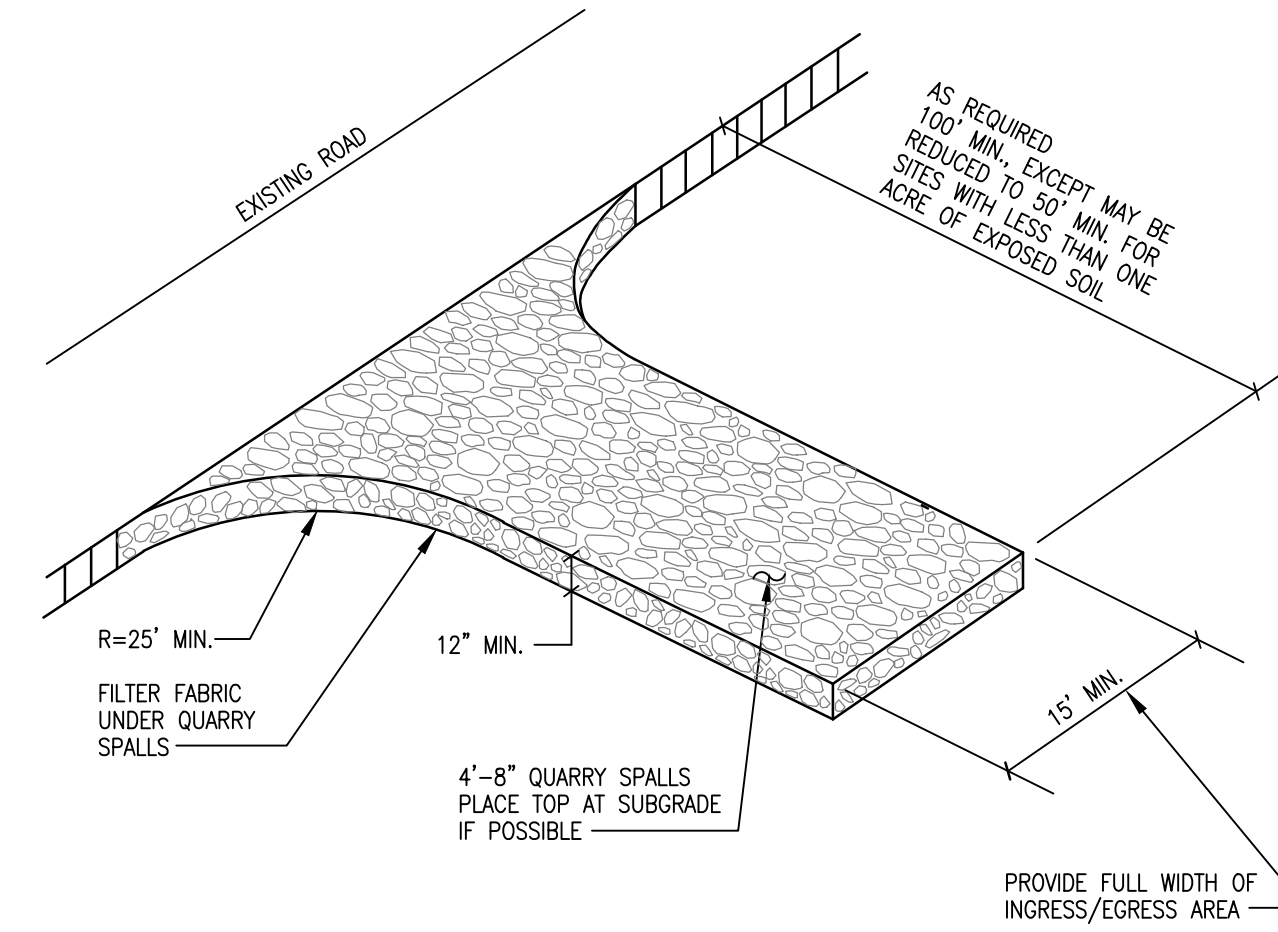

STABILIZED CONSTRUCTION ENTRANCE
NO SCALE

NOTES:

1. STONE SIZE - USE 4" STONE, OR RECLAIMED OR RECYCLED CONCRETE EQUIVALENT.
2. LENGTH - AS REQUIRED, BUT NOT LESS THAN 50 FEET (EXCEPT ON A SINGLE RESIDENCE LOT WHERE A 30 FOOT MINIMUM LENGTH WOULD APPLY).
3. THICKNESS - NOT LESS THAN 12"
4. WIDTH - 15 FOOT MINIMUM, BUT NOT LESS THAN THE FULL WIDTH AT POINTS WHERE INGRESS OR EGRESS OCCURS.
5. FILTER CLOTH - WILL BE PLACED OVER THE ENTIRE AREA PRIOR TO PLACING OF STONE. FILTER WILL NOT BE REQUIRED ON A SINGLE FAMILY RESIDENCE LOT.
6. SURFACE WATER - ALL SURFACE WATER FLOWING OR DIVERTED TOWARD CONSTRUCTION ENTRANCES SHALL BE PIPED ACROSS THE ENTRANCE. IF PIPING IS IMPRACTICAL, A MOUNTABLE BERM WITH 5:1 SLOPES WILL BE PERMITTED.
7. MAINTENANCE - THE ENTRANCE SHALL BE MAINTAINED IN A CONDITION WHICH WILL PREVENT TRACKING OR FLOWING OF SEDIMENT ONTO PUBLIC RIGHT-OF-WAY. THIS MAY REQUIRE PERIODIC TOP DRESSING WITH ADDITIONAL STONE AS CONDITIONS DEMAND AND REPAIR AND/OR CLEANOUT OF ANY MEASURES USED TO TRAP SEDIMENT. ALL SEDIMENT SPILLED, DROPPED, WASHED OR TRACKED ONTO PUBLIC RIGHT-OF-WAY MUST BE REMOVED IMMEDIATELY.
8. WASHING - WHEELS SHALL BE CLEANED TO REMOVE SEDIMENT PRIOR TO ENTRANCE ONTO PUBLIC RIGHT-OF WAY. WHEN WASHING IS REQUIRED, IT SHALL BE DONE ON AN AREA STABILIZED WITH STONE AND WHICH DRAINS INTO AN APPROVED SEDIMENT TRAPPING DEVICE.
9. PERIODIC INSPECTION AND NEEDED MAINTENANCE SHALL BE PROVIDED AFTER EACH RAIN.

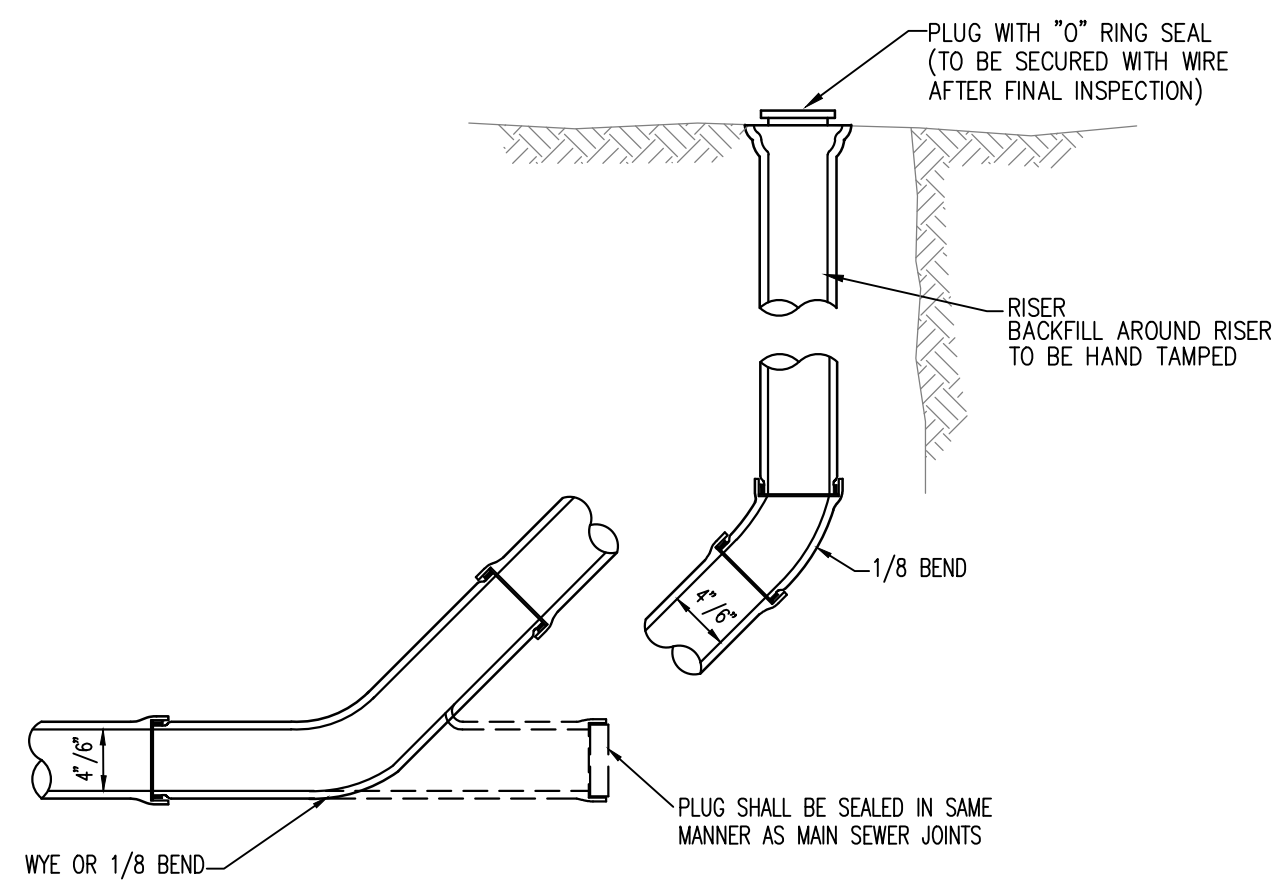

- NOTE:**
1. FOR SIDE SEWER AND SERVICE DRAINS ON UNPAVED AREA.

CLEANOUT DETAILS
NTS

REVISION	
NO.	
DATE	

C2MY
C2MY ENGINEERS, LLC
PO BOX 52883
BELLEVUE, WA 98015
(206) 922-9376
cmchin@c2my.com

DATE:
09-11-24

PROJECT: DANN RESIDENCE
3008 10TH AVENUE SE
MERCER ISLAND, WA 98040

TESC AND DRAINAGE DETAILS

FILE NO:
2405
DWS

SHEET
C1.1

SW 1/4, NW 1/4, SEC 12, TWP. 24N., RGE 4E., W.M.

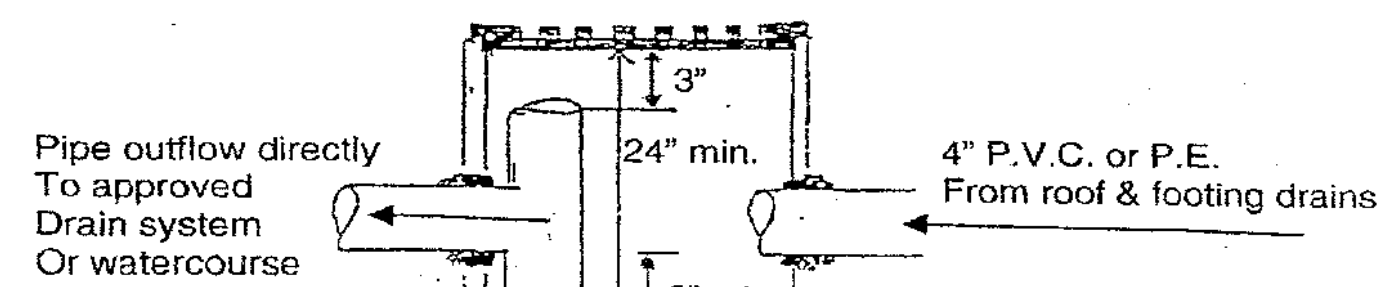
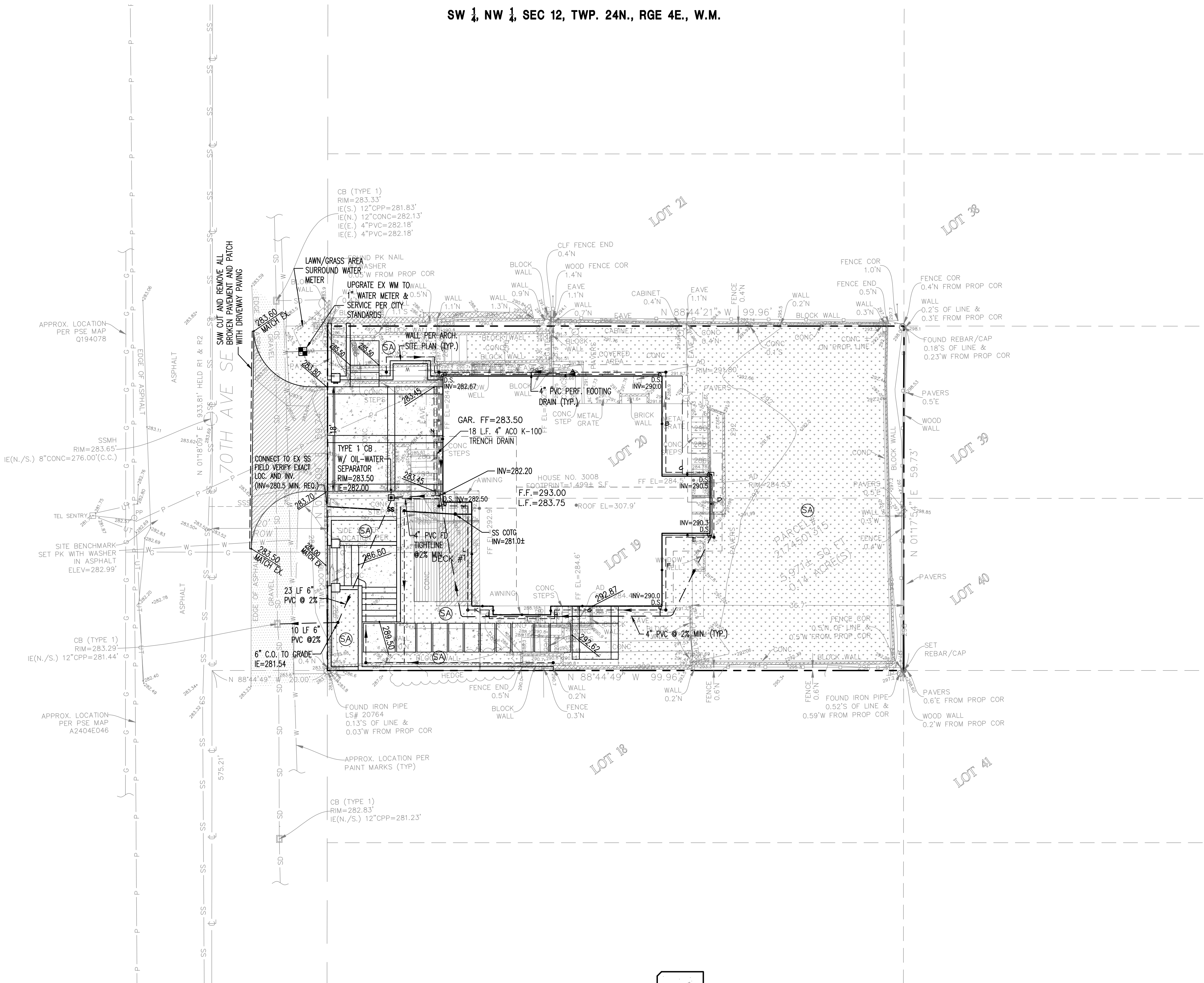

Catch Basin with Oil Separator

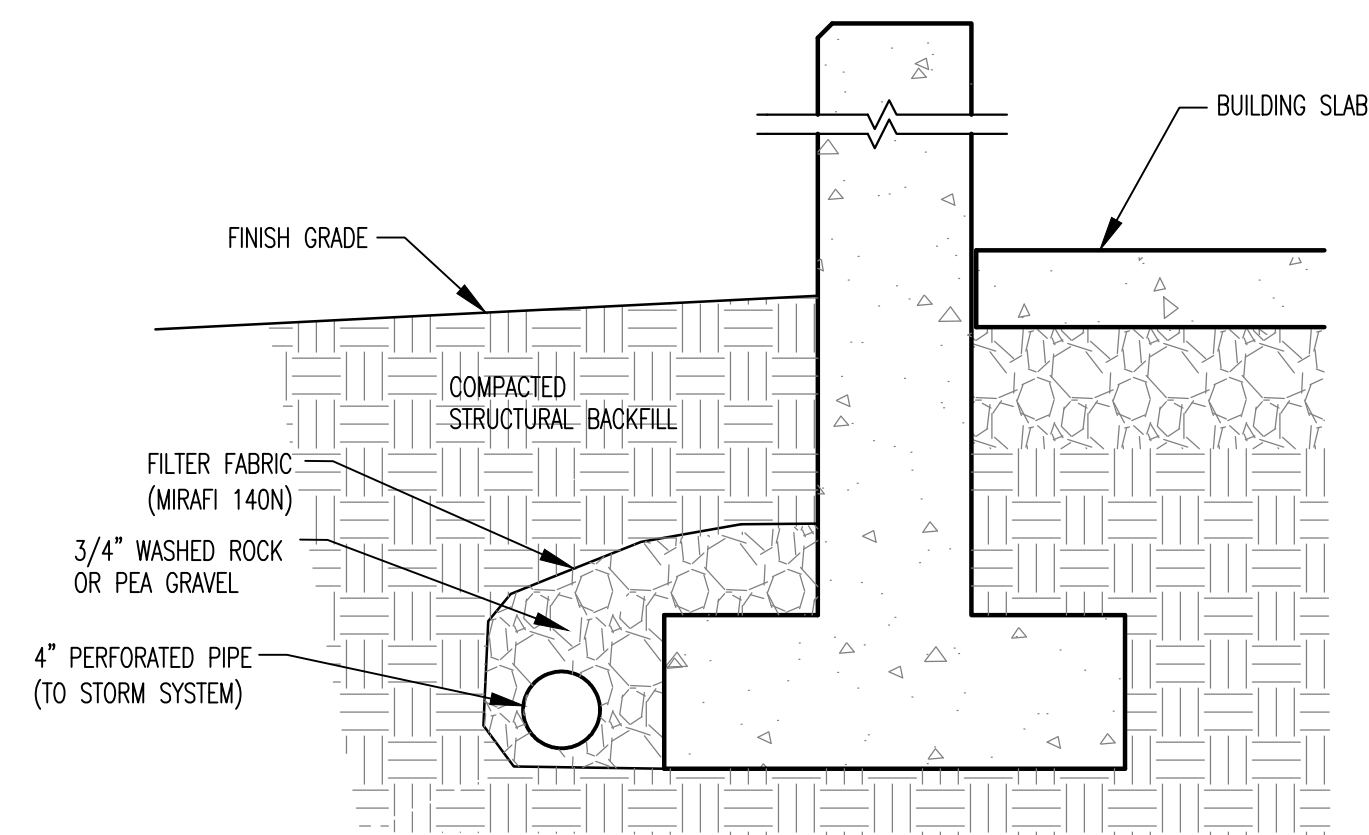

FOOTING DRAIN DETAILS

SOIL AMENDMENT NOTE:

THE LAWN AND LANDSCAPE AREAS ARE REQUIRED TO PROVIDE POST-CONSTRUCTION SOIL QUALITY AND DEPTH IN ACCORDANCE WITH BMP 15.13. THE PROJECT CIVIL ENGINEER MUST PROVIDE A LETTER OF CERTIFICATION TO ENSURE THAT THE LAWN AND LANDSCAPE AREAS ARE MEETING THE POST-CONSTRUCTION SOIL QUALITY AND DEPTH REQUIREMENTS SPECIFIED ON THE APPROVED PLAN SET PRIOR TO FINAL INSPECTION OF THE PROJECT.

SIDE SEWER NOTE:

THE TV INSPECTION OF THE EXISTING SIDE SEWER TO THE CITY SEWER MAIN IS REQUIRED. IF THE RESULT OF THE TV INSPECTION IS NOT IN SATISFACTORY CONDITION, AS DETERMINED BY THE CITY OF MERCER ISLAND INSPECTOR, THE REPLACEMENT OF THE EXISTING SIDE SEWER IS REQUIRED.

SITE IMPERVIOUS AREA SUMMARY:

EXISTING LOT AREA = 5,971 S.F.
 EXISTING BUILDING ROOF = 2,129 S.F.
 EXISTING DRIVEWAY = 294 S.F.
 EXISTING WALKWAY = 674 S.F.
 TOTAL EXISTING HARD SURFACES AREA = 3,169 S.F.
 EXISTING IMPERVIOUS IS 53.1% > 35% (REDEVELOPMENT FLOW CHART)

PROPOSED DRIVEWAY WITHIN ROW = 279 S.F.
 PROPOSED DRIVEWAY WITHIN PROPERTY = 363 S.F.
 PROPOSED WALKWAY = 418 S.F.
 PROPOSED BUILDING ROOF = 1,833 S.F.
 PROPOSED DECK = 168 S.F.
 TOTAL NEW HARD SURFACES AREA = 2,782 S.F. < 5000 S.F.

PER FIGURE I-3.2 FLOW CHART FOR DETERMINING REQUIREMENT FOR REDEVELOPMENT: MINIMUM #1 TO #5 APPLIED TO NEW AND REPLACED HARD SURFACES AND THE LAND DISTURBED

NET DECREASE IN IMPERVIOUS AREA ON-SITE = 387 S.F.

LEGEND

- EX. SANITARY SEWER ——— SS ———
- EX. WATER LINE ——— W ———
- EX. STORM DRAIN ——— SD ———
- CONCRETE DRIVEWAY [Pattern]
- SOIL AMENDMENT-SA [Pattern]
- SAW CUT LINE - - - - -
- ROOF DRAIN TIGHTLINE WITH C.O.T.G.(4" PVC) ———
- FOOTING DRAIN W/ CLEANOUT TO GRADE (C.O.T.G.) ———

NOTES:

1. SEE ARCHITECTURE SITE PLAN FOR OTHER PROPOSED INFORMATION NOT SHOWN ON THIS SHEET.

DRAINAGE GENERAL NOTES:

1. DOWNSPOUTS SHALL BE TIED INTO A NON-PERFORATED, RIGID, SMOOTH-BORE PIPE WHICH DRAINS TO AN APPROVED STORM SYSTEM
2. PROVIDE CLEANOUTS AT THE UPPER END OF THE SYSTEM AND AT EACH CUMULATIVE CHANGE OF DIRECTION IN EXCESS OF 135 DEGREES.
3. ALL PIPE FITTINGS SHALL BE MADE OF THE SAME MATERIAL AS THE STRAIGHT PIPE. GLEED JOINTS SHALL USE A BONDING AGENT RECOMMENDED BY THE PIPE MANUFACTURER.
4. FOOTING DRAINS SHALL BE INSTALLED AROUND ALL NEW FOUNDATIONS AND SHALL BE TIGHTLINED TO DISCHARGE TO THE SPLASH BLOCK. FOOTING DRAINS SHALL BE CONSTRUCTED OF PERFORATED PIPE AT THE BASE OF THE FOOTING, AND SHALL MEET MATERIAL STANDARDS OF D2729 FOR PVC PIPE, WITH THE PERFORATIONS DIRECTED DOWNWARD. PLACE GRANULAR BACKFILL AROUND AND ABOVE THE FOOTING DRAIN TO A DEPTH OF 2/3 OF THE WALL HEIGHT. PROVIDE FILTER FABRIC WRAP AROUND BETWEEN THE GRANULAR BACKFILL AND THE NATIVE SOIL.

BENCHMARK AND DATUM PER SURVEY

NAD 83(2011) WASHINGTON NORTH STATE PLANE COORDINATES PER GPS OBSERVATIONS
 NAVD 88 PER GPS OBSERVATIONS



Know what's below.
Call before you dig.

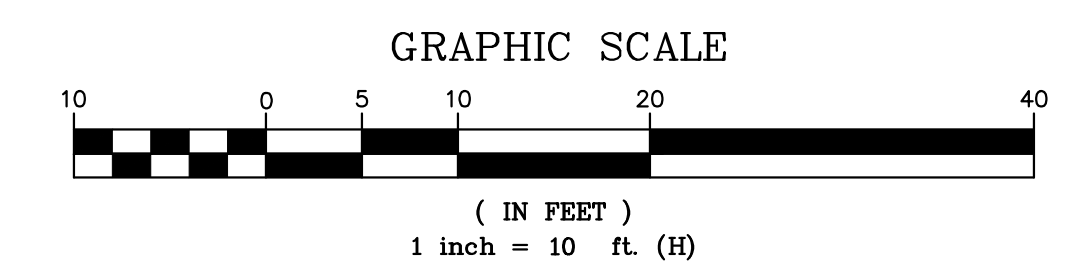

	REVISION			
NO.	DATE	REVISED PER	CITY COMMENTS	
1	06-28-2024			
C2MY ENGINEERS, LLC PO BOX 52883 BELLEVUE, WA 98015 (206) 922-9376 cmchin.c2my@gmail.com				
DATE: 09-11-24				
PROJECT: DANN RESIDENCE 3008 10TH AVENUE SE MERCER ISLAND, WA 98040 Paving, Grading, Drainage Plan				
FILE NO: 2409 DW5				
SHEET C2.0				

GENERAL STRUCTURAL NOTES:

CRITERIA:

1.1 All Materials, workmanship, design, and construction shall conform to the drawings, specifications, and the Seattle Building Code (SBC), 2018 Edition.

1.2 Design Loading Criteria
The Design Loading of the Structure is as follows:

Live Loads (in accordance with SCB Table 1607.1)			
Occupancy or Use	Uniform Live Load	Concentrated Live Load	Notes
Floor, Residential	40-psf	-	
Balconies & Decks	60-psf	-	1.5 x Occupancy Load
Uninhabitable attic, with storage	20-psf	-	Concurrent with Snow Loads
Uninhabitable attic, without storage	10-psf	-	Non-concurrent with Snow Loads
Handrails and Guards	-	200-lbs	Any point, any direction (ASCE 7-16, Section 4.5.1)

Wind Design Data ASCE 7-16, Chapter 28: Simplified Envelope Procedure		Seismic Design Data ASCE 7-16, Section 12.8: Equivalent Lateral Force Procedure	
Basic Design Wind Speed (3-sec gust), V	100 mph	Risk Category	II
Risk Category	II	Seismic Importance Factor, I _s	1.0
Wind Exposure	B	Mapped Spect. Accel., Short Period, S _s	1.405
Internal Pressure Coefficient	N/A	Mapped Spect. Accel., 1-Sec, S ₁	0.489
Exterior Components and Cladding	25-psf	Site Class	D
Topographical Factor, K _{zt}	1.60	Spectral Response Coeff., Short Period, S _{DS}	1.124
		Spectral Response Coeff., 1-Sec, S _{D1}	0.590
		Seismic Design Category	D

Snow Loads (ASCE 7-16, Chapter 7)		Ply. Shear Walls	
Ground Snow Load, P _g	25-psf	Response Modification Factor, R	6.5
Flat Roof Snow Load, P _f = 0.7 C _e C _t I _s P _g	25-psf	Seismic Response Coefficient, C _s	0.173
* Snow Exposure Factor, C _e	1.0	Design Base Shear, V	20.8 Kips
* Snow Load Importance Factor, I _s	1.0		
* Thermal Factor, C _t	1.2		

Do not adjust for slope or drift unless noted on the Drawings. See Drawings for Additional Loading Criteria.

1.3 Structural Drawings shall be used in conjunction with all other project documents for bidding and construction. Contractor shall verify dimensions and conditions for compatibility and shall notify architect of all discrepancies prior to construction.

1.4 Contractor shall provide Temporary Bracing for the structure and structural components until all final connections have been completed in accordance with the drawings.

1.5 Contractor shall be responsible for all safety precautions and the methods, techniques, sequences or procedures required to perform the work.

1.6 Contractor-initiated changes shall be submitted in writing to the Architect and Structural Engineer for approval prior to fabrication or construction. Changes shown on shop drawings only will not satisfy this requirement.

1.7 Drawings indicate general and typical details of construction. Where conditions are not specifically indicated but are of similar character to details shown, similar details of construction shall be used, subject to review and approval by the Architect and the Structural Engineer.

1.8 All structural systems composed of components to be field erected shall be supervised by the Supplier during manufacturing, delivery, handling, storage and erection in accordance with instructions prepared by the Supplier.

GEOTECHNICAL:

2.1 Allowable Soil Pressure, Lateral Earth Pressure, and Soil Profile Type assume IBC prescribe minimum. Footings shall bear on firm, undisturbed earth at least 18" below adjacent finished grade. Notify Structural Engineer if suitable soils not present. Unless otherwise noted, footings shall be centered below columns or walls above. Backfill behind all retaining walls with free draining, granular fill and provide for subsurface drainage.

Geotechnical Properties	
Soil Site Class	D
Allowable Soil Bearing Pressure	1500-psf
Active Lateral Earth Pressure (Restrained)	60-pcf
Active Lateral Earth Pressure (Unrestrained)	35-pcf
Seismic Lateral Earth Pressure	6H-psf
Passive Lateral Earth Pressure	300-pcf
Base Friction Coefficient	0.35

CONCRETE:

3.1 Concrete shall be mixed, proportioned, conveyed and placed in accordance with SBC Chapter 19 and ACI 318-14. Mix shall be proportioned to produce a slump of 5" or less. All concrete with surfaces exposed to standing water shall be air-entrained with an air-content conforming to ACI 318-14 Table 19.3.3.1. Concrete Strength, based on SBC Section 1904.1, shall be as follows:

Type or Location of Concrete Construction (Moderate Exposure)	Min. 28-Day Compressive Strength, f _c
Interior Slabs-on-Grade	2500-psi
Footings, Basement Walls, Foundation/Stem Walls	3000-psi ¹

¹ Specified compressive strength (f_c) specifications address serviceability requirements. Design strength of concrete is 2500-psi, therefore, strength tests are not required. Provided concrete mix tickets verifying strength specifications.

3.2 Reinforcing Steel shall conform to ASTM A615/A615M-18e1 and the following:

Bar Size	Steel Grade
#5 bar and larger	Grade 60, f _y = 60,000-psi
#4 bar and smaller	Grade 40, f _y = 40,000-psi

Welded Wire Fabric shall conform to ASTM A1064/A1064M-18a

3.3 Reinforcing Steel shall be detailed (including hooks and bends) in accordance with ACI 318-14. Lap all continuous reinforcement (#5 and smaller) 2'-0" minimum. Laps of larger bars (#6 and #7) shall be 3'-0", min. Provide corner bars at all wall and footing intersections and lap 2'-0" minimum. Lap adjacent mats of welded wire fabric a minimum of 8" at sides and ends.

No bars partially embedded in hardened concrete shall be field bent unless otherwise noted on the drawings or approved by the structural engineer.

3.4 Concrete Protection (cover) for Reinforcing Steel shall be as follows:

Condition	Clear Cover
Footings and Unformed Surfaces cast against and permanently exposed to Earth	3"
Formed Surfaces exposed to Earth or Weather (#6 bars or larger)	2"
Formed Surfaces exposed to Earth or Weather (#5 bars or smaller)	1½"
Slabs and Walls, interior face (#11 bars and smaller)	¾"
Column Ties or Spirals and Beam Stirrups	1½"

STEEL:

5.1 Structural Steel design, fabrication, and erection shall be based on the following documents:

- AISC 360-16: Specification for Structural Steel Buildings
- AISC 341-16: Seismic Provisions for Structural Steel Buildings
- AISC 303-16: Code of Standard Practice for Steel Buildings and Bridges
- Specification for Structural Joints using high strength bolts (dated June 11, 2020), prepared by research council on structural connections, RCSC Committee A.1

5.2 Structural Steel shall conform to the following requirements:

Type of Member	ASTM Specification	F _y
Standard Shapes	A992	50 ksi
Plates, Angles & Rods	A36	36 ksi
Hollow Structural Sections (Tube Steel)	A500 (Grade B)	46 ksi
Anchor Bolts	F1554	36 ksi
Connection Bolts	A325-N or F1852-N	

5.3 Dimensional Tolerance for Structural Steel members shall be per the AISC 303-16, Section 6.4 and ASTM Specification A6/A6M. Unless specifically allowed by the Engineer, column members shall not be modified by the rotary straightening process.

5.4 All Welding shall be in conformance with AISC and AWS Standards and shall be performed by WABO certified welders using E70xx electrodes. Only prequalified welds (as defined by AWS) shall be used.

WOOD:

6.1 Framing Lumber shall be kiln dried or MC-19, and graded and marked in conformance with WCLB Standard Grading Rules for West Coast Lumber No. 17. Unless otherwise noted, furnish to the following minimum standards:

Member Use	Size	Species	Grade
Studs	2x, 3x	Hem-Fir or SPF	STUD
Joists/Rafters	2x, 3x	Hem-Fir	No. 2
Plates/Misc.	2x, 3x	Douglas Fir-Larch	No. 2
Beams	4x	Douglas Fir-Larch	No. 2
Posts	4x	Douglas Fir-Larch	No. 2
Timber, Beams	6x & Larger	Douglas Fir-Larch	No. 2
Timber, Posts	6x & Larger	Douglas Fir-Larch	No. 2

6.2 Glued Laminated Members shall be fabricated in conformance with ASTM and AITC Standards. Each member shall bear an AITC Identification Mark and shall be accompanied by an AITC certificate of conformance. Furnish to the following minimum standards:

Member Use	Combination	Species	F _{bx}	F _{by}	F _{cx}	F _{cy}	E _x
Beams	24F-V4	DF/DF	2400-psi	1850-psi	650-psi	265-psi	1800-ksi

Camber all glulam beams to 3,500" radius, unless otherwise noted. Glued laminated members exposed to weather or moisture shall be treated with an approved preservative.

6.3 Engineered Wood shown on the drawings are based on product manufactured by Weyerhaeuser in accordance with ICC Report No. ES ESR-1387. Alternate manufacturers may be used subject to review and approval by the Architect and Structural Engineer. All hangers and other hardware not shown shall be designed and supplied by the Joist Manufacturer. Each piece shall bear a stamp or stamps noting the name and plant number of the manufacturer, the grade, the ICC report number, and the quality control agency. Furnish to the following minimum standards:

Member Use	Product	F _b	F _{c⊥}	F _v	E
Beams	1.55E Laminated Strand Lumber (LSL)	2325-psi	800-psi	310-psi	1550-ksi
Beams	2.0E Laminated Veneer Lumber (LVL)	2600-psi	750-psi	285-psi	2000-ksi
Beams	2.0E Parallel Strand Lumber (PSL)	2900-psi	750-psi	290-psi	2000-ksi
Rim Boards	Laminated Strand Lumber (LSL)	1700-psi	680-psi	400-psi	1300-ksi

6.4 Engineered Wood I-Joists shown on the drawings are based on joists manufactured by Weyerhaeuser in accordance with ICC Report No. ES ESR-1153. Alternate Engineered Wood I-Joists manufacturers may be used subject to review and approval by the Architect and Structural Engineer.

6.5 Prefabricated Connector Plate Wood Trusses shall be designed by the manufacturer in accordance with TPI 1-2014 for the spans and conditions shown on the drawings. Wood trusses shall utilize approved connector plates (MITEK, ITW or other approved Truss Plate Manufacturer).

Unless otherwise noted, loading shall be as follows:

Roof Truss Design Loading	
Member	Uniform Load
Top Chord Snow Load	25-psf
Top Chord Wind Load (Uplift)	15-psf
Top Chord Dead Load	7-psf
Bottom Chord Live Load	10-psf
Bottom Chord Dead Load	5-psf

Floor Truss Design Loading	
Member	Uniform Load
Top Chord Live Load	40-psf
Top Chord Dead Load	10-psf
Bottom Chord Dead Load	5-psf

Submit shop drawings and design calculations prior to fabrication. Submitted documents shall bear the stamp and signature of a registered Professional Engineer, State of Washington. Truss design drawings shall include, at a minimum, the following:

- Slope or Depth, Span and Spacing
- Location of all Joints and Support Locations
- Number of Plies if greater than one
- Required Bearing Widths
- Design Loads and Locations: Include Top and Bottom Chord Live and Dead Loads, Girder Loads, and Environmental Loads (Seismic, Wind, Snow, etc.)
- Other Lateral Loads, including Drag Strut Loads
- Adjustments to Wood and Metal Connector Plate Design Value for Conditions of Use
- Maximum Reaction Force and Direction (including Maximum Uplift)
- Metal-Connector-Plate Type, Size, Thickness, and Location
- Size Species and Grade for each Member
- Truss-to-Truss Connections and Truss Field Assembly Requirements
- Calculated Span-to-Deflection Ratio and maximum Vertical and Horizontal Deflection for Live and Total Loads
- Maximum Axial Tension and Compression Forces in each Truss Member
- Required Permanent Individual Truss Member Restraint Location and the Method and Details of Restraint Bracing to be used
- Placement Layout including Bearing Points, Intersections, Hips, Valleys, etc.
- Truss-to-Truss and Truss-to-Beam Connection Details and Hardware

6.6 Roof Floor & Wall Sheathing shall be APA Rated, Exterior or Exposure 1 Plywood or OSB manufactured under the provisions of Voluntary Product Standards DOC PS-1 or DOC PS-2, or APA PRP-108 Performance Standards and Policies for Structural Use Panels. See Drawings for thickness, span rating, and nailing requirements. Unless otherwise noted, wall sheathing shall be ½" (nominal) with Span Rating of 24/0. Glue floor sheathing to all supporting members with adhesive conforming to APA Specification AFG-01.

6.7 Wood members shall be protected against decay and termites in accordance with SBC Section 2304.12. Where required, members shall be naturally durable species or shall be treated with waterborne preservatives wood in accordance with American Wood Protection Association specification AWPA U1. Members shall be clearly labeled. Modified treated members (ripped or end cut) shall be field treated in accordance with specification AWPA M4.

6.8 Timber Connectors and Proprietary Fasteners shall be "Strong-Tie" by Simpson Company, as specified in their current catalog. Provide number and size of fasteners as specified by manufacturer. Connectors shall be installed in accordance with the manufacturer's instructions. Where connector straps connect two members, center strap on joint and provide number and size of fasteners as specified by manufacturer, with equal number and size of fasteners in each member.

Alternate hardware manufacturer substitutions, such as USP Connectors, shall be ICC approval for equal or greater load capacities. All joint hangers and other hardware shall be compatible in size with specified framing members. See Hanger Conversion Table for pre-approved substitutions.

Timber Connectors and their fasteners shall be protected from corrosion in accordance with manufacturer's recommendations or ASTM A 653, Type G185.

WOOD (Continued):

6.10 Wood Framing Notes: The following apply unless otherwise noted on the drawings:

- All wood framing details shall be constructed to the minimum standards of the IBC. Nailing not specified on the drawings shall conform to IBC Table 2304.10.1 or ICC ES ESR-1539. Coordinate the size and location of all openings with Mechanical and Architectural Drawings.
- Wall Framing: Stud wall size and spacing shall be in accordance with the plan notes. Two studs minimum shall be provided at the ends of all walls, at each side of all openings, and at the ends of all beams and headers. All stud bearing walls on wood framing shall have their lower wood plates attached to framing or concrete below per P1-6 of the shear wall schedule.
- Individual members of Built-Up stud posts shall be nailed to each other with framing nails @ 12"oc, staggered. Individual members of Built-Up joist beams shall be nailed to each other with framing nails @ 12"oc, staggered.
- Solid blocking for wood columns shall be provided through floors to supports below.
- Floor and Roof Framing: Provide solid blocking at all bearing points. Toenail joists to supports with two framing nails. Attach timber joists to flush headers or beams with metal joist hangers in accordance with notes above.
- Roof and floor sheathing shall be laid up with grain perpendicular to supports and nailed per plan notes. Allow 1/8" spacing at all panel edges and ends of floor and roof sheathing. Provide approved panel edge clips centered between joists/trusses at unblocked roof sheathing edges. All floor sheathing edges shall have approved tongue-and-groove joints. Toenail blocking to supports with framing nails @ 12"oc. At blocked floor and roof diaphragms, provide flat 2x blocking at all unframed panel edges and nail with edge nailing specified.

6.9 Dowel-Type Fasteners (Bolts, Lag Screws, Wood Screws and Nails) shall conform to Sections 11 and 12 of the ANSI/AWC NDS-2018.

Dowel Type Fastener	Grade	Requirements at Exterior Use or when in Contact w/ Treated Lumber	Installation
Bolts	ASTM A307	ASTM B 695, Class 55 Galvanized or Stainless Steel	ANSI/AWC NDS-2018 Section 12.1.3 Hole = Bolt Ø + (1/32" to 1/16") Washer @ Bolt Head and @ Nut
All-Thread/Threaded Rod	ASTM F1554	ASTM B 695, Class 55 Galvanized or Stainless Steel	ANSI/AWC NDS-2018 Section 12.1.3 Hole = Rod Ø + (1/32" to 1/16") Washer @ Each Nut
Lag Screws	ASTM A307	ASTM A 153 Galvanized or Stainless Steel	ANSI/AWC NDS-2018 Section 12.1.4 Lead Hole = 0.5 x Shank Ø; Shank Hole = Shank Ø Washer @ Lag Head
Wood Screws		ASTM A 153 Galvanized or Stainless Steel	ANSI/AWC NDS-2018 Section 12.1.5 Pilot Hole = 0.75 x Root Ø (Unless Self-Boring)
Nails	ASTM F1667	ASTM A 153 Galvanized or Stainless Steel	ANSI/AWC NDS-2018 Section 12.1.6 Avoid Overdriving or Underdriving; Avoid Wood Splitting Toenails 30°, 1/3 Nail Length from Joint

Nails specified on the drawings shall be as follows:

Nail Use	Penny Weight	Grade
Framing Nails	12d Box	0.131"Ø x 3½"
Sheathing Nails	8d Common	0.131"Ø x 2½"

All Metal Fasteners exposed to weather or in contact with treated wood shall be protected from corrosion according to table above. Nuts and bolts exposed to weather or in contact with treated wood shall be galvanized in accordance with ASTM A153/A153M-16a or Stainless Steel. See above for Proprietary Fastener requirements. Do not substitute standard Dowel-Type Fasteners for Proprietary Fasteners unless specifically allowed.

QUALITY ASSURANCE:

7.1 See Special Inspection and Testing Requirements Table for inspection and testing requirements. Special Inspection shall be in accordance with SBC Section 1704.2. Standard inspections shall be in accordance with SBC Section 110.

7.2 Structural Observation in accordance with SBC Section 1704.6 is required.

SPECIAL INSPECTION AND TESTING REQUIREMENTS			
Verification and Inspection	Continuous	Periodic	Comments
Soils	-	-	Refer to Geotechnical Report
Concrete	-	-	Provide Batch Mix Tickets
Concrete Retaining Walls Basement Walls	-	X	
Post-Installed Anchors in Concrete	X	-	
Ordinary Steel Moment Frame - Fabrication	-	-	Fabricator shall submit shop drawings and QA/QC procedures as a deferred submittal
Ordinary Steel Moment Frame - Installation	X	-	Field welds of moment frame base to steel wide flange beam.

Hanger Conversion Table		
TYPE	SIMPSON STRONG-TIE PRODUCT #	USP CONNECTORS PRODUCT #
HOLD-DOWNS	HDX-SDS2.5	PHDA
	STHD14/STHD14RJ	STAD14/STAD14RJ
	DTT12	LTS19-TZ w/ 1"x1½" PLATE WASHER (70 KCCQXSDS5.5)
STRAPS	MST48	KST248
	ST2215	KST216
	ST6224	KST224
	CS16	RS150
	MASA/MASAP	FA4
	CMSTC16	CMSTC16
ANGLES/TIES	LG2	LUG2
	LTP4	MP4F
	LTP5	MP5F
	A34	MP34
	A35	MPA1
	H1	RT15
POST CAPS	H2.5	RT7
	H2.5A	RT7A
	LPCXZ	PBXx6TZ
	LCE4	PBE574
	EPCxx	EPCMxx
	CCQxxSDS5.5	KCCQxx
POST BASES	ECCQxxSDS5.5	KECCQxx
	ACx	PBSxx
DRAG STRUTS	PBXx	WEXx
	ABUxx	PAUxx
	ABAXx	PAXxE
	HTS30C	HTW30C
HANGERS	HTS30	HTW30
	DSC5	DSC4
	LUSxx	JUSxx
	IUSxx	THFx
	ITTx	THOxx
	HUxx / HUCxx	HDxx / HDxxF
MUxx	THFx	
HUSxx	HUSxx	

RUDOLPH
ARCHITECTS
5273 140th Avenue N.E., Bellevue, Washington
425 555-5588

BTL
ENGINEERING P.S.
10000 WOODLAND AVENUE, SUITE 1000, WASHINGTON, WA 98149
PH: 206.444.8888 FAX: 206.444.8888

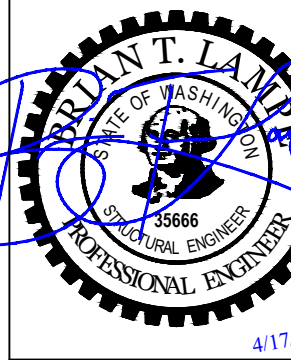

PERMIT 3/3/2024
PERMIT UPDATE 10/1/2024
PLAN REVIEW 01/09/2025
PLAN REVIEW 2 04/17/2025

Revisions To A New Residence for
Teddy and Megan Dann
3008 70th Avenue S.E. - Mercer Island, WA 98040

S1

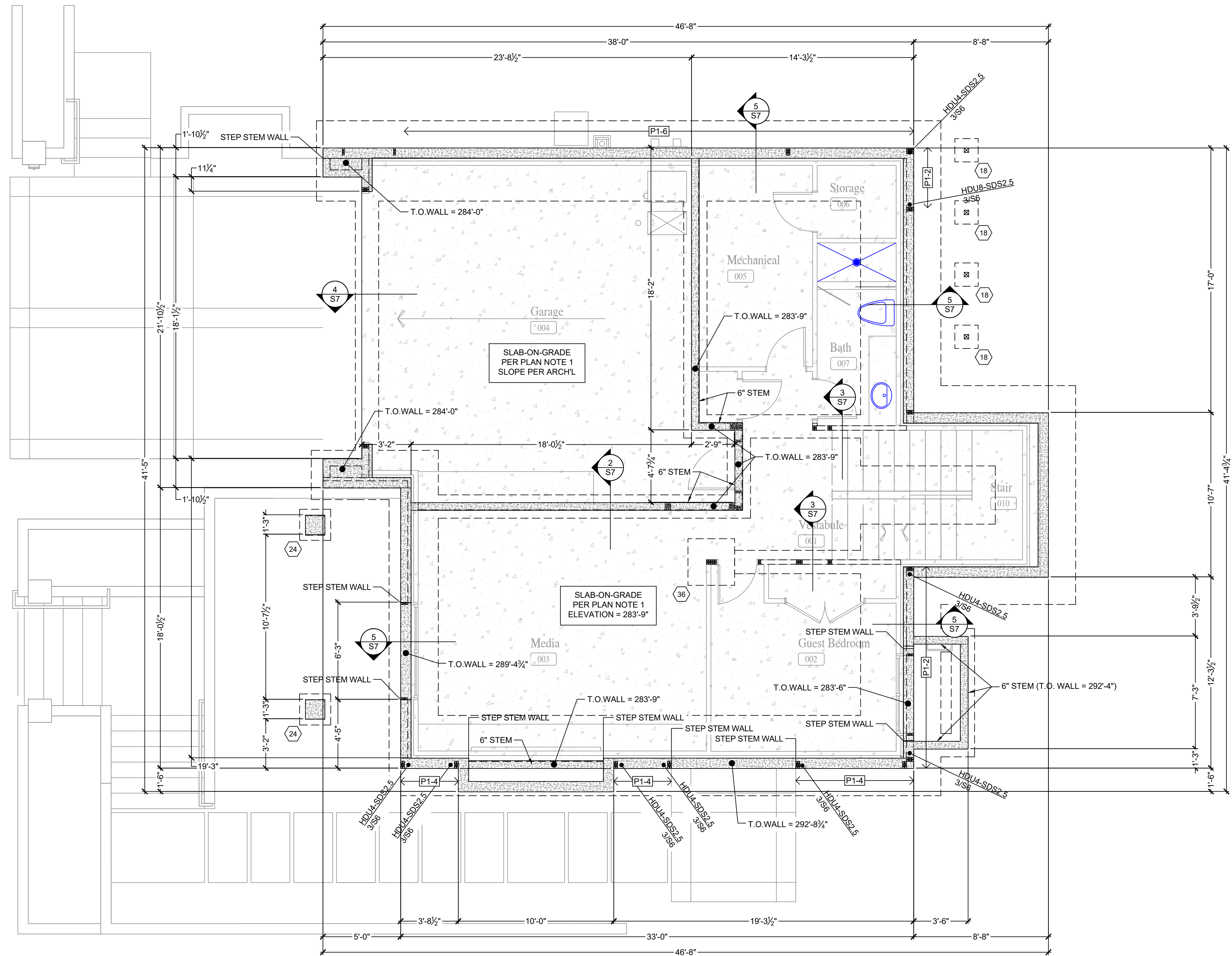

- FOUNDATION PLAN NOTES:**
1. SLAB-ON-GRADE SHALL BE 4" THICK WITH 6x6 W/ 4xW/ 4 W/M AT CENTER, U.O.N. SLAB SHALL BE POURED OVER BASE SOIL PREPARED IN ACCORDANCE WITH THE GEOTECHNICAL REPORT. SLABS SHALL BE POURED OVER 10MIL VAPOR BARRIER PLACED OVER FREE-DRAINING GRANULAR FILL. SEE ARCHITECTURAL DRAWINGS FOR SLAB ELEVATION, DEPRESSION, AND SLOPE REQUIREMENTS. W/M MAY BE OMITTED IF SLAB CONCRETE MIX INCLUDES FIBROUS REINFORCEMENT PER GENERAL STRUCTURAL NOTES.
 2. PROVIDE CONSTRUCTION/CONTROL JOINT IN SLAB PER ARCHITECTURAL DRAWINGS. AREAS SHALL BE APPROXIMATELY SQUARE AND 400-SF OR LESS.
 3. BOTTOM OF FOOTINGS SHALL BE SET ON COMPETENT, PROPERLY COMPACTED BEARING SOIL BELOW FROST DEPTH. THE CONTRACTOR SHALL DETERMINE ACTUAL FOOTING ELEVATIONS BASED ON FINAL GRADES AND SITE CONDITIONS. CONSULT WITH THE GEOTECHNICAL ENGINEER AS REQUIRED.
 4. ANCHOR BOLTS FOR EXTERIOR STUD WALLS SHALL BE IN ACCORDANCE WITH P1-6 OF THE SHEAR WALL SCHEDULE OF 1/S6, U.O.N.
 5. TOP OF STEM WALL ELEVATION SHALL BE 292'-9 1/2", U.O.N.

LEGEND

	DETAIL CALL-OUT
	ANCHOR BOLTS FOR SHEAR WALL ABOVE PER SCHEDULE OF 1/S6
	SLAB-ON-GRADE PER PLAN NOTE 1
	FOUNDATION WALL AND FOOTING
	BEARING OR SHEAR WALL ABOVE
	FOOTING CALLOUT - SEE 4/S6

FOUNDATION PLAN

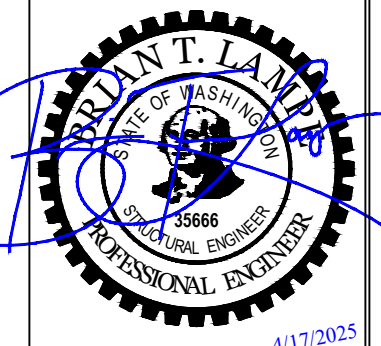
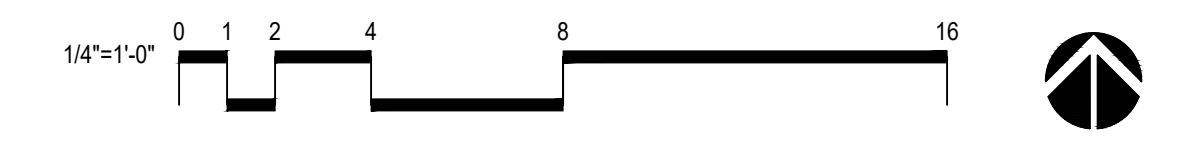

PERMIT	3/3/2024
PERMIT UPDATE	10/12/2024
PLAN REVIEW	01/09/2025
PLAN REVIEW 2	04/17/2025

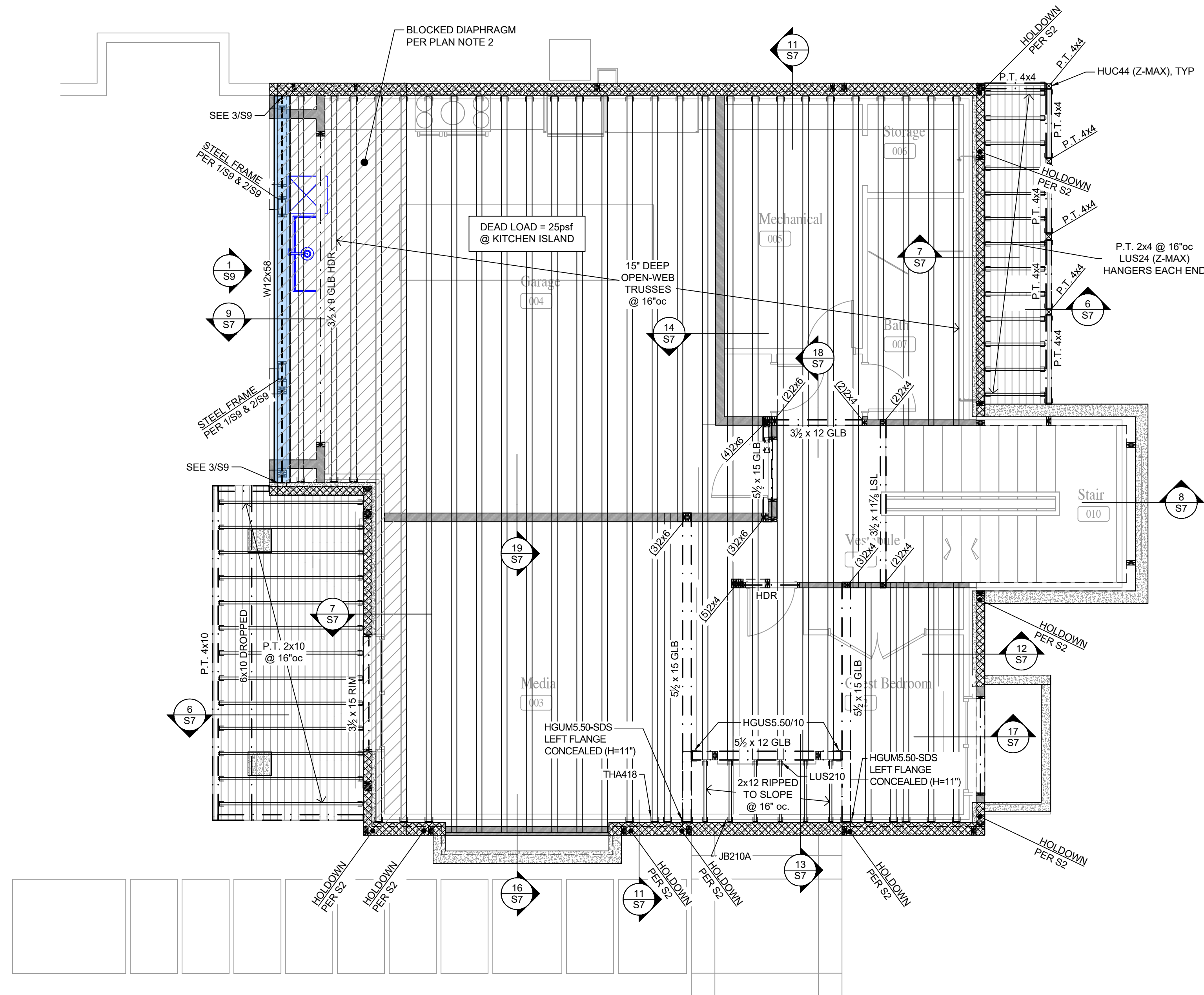

FLOOR FRAMING PLAN NOTES:

1. FLOOR SHEATHING SHALL BE 7/8\"/>

FRAMING, EDGES	6\"/>
FRAMING, EDGES @ BLOCKED DIAPHRAGM	4\"/>
FRAMING, FIELD	10\"/>
BOUNDARIES, BLOCKING, STRUTS	5\"/>

AT AREAS INDICATED AS BLOCKED DIAPHRAGM, PROVIDE 2x FLAT BLOCKING (PER GENERAL STRUCTURAL NOTES) AT ALL UNFRAMED SHEATHING PANEL EDGES. FASTEN SHEATHING TO FRAMING AND BLOCKING WITH WSV212 SUBFLOOR SCREWS (#9 x 2 1/2\") or 0.131\"/>

SEE DRAWINGS FOR OTHER SHEATHING NAILING REQUIREMENTS.

2. AT AREAS INDICATED AS BLOCKED DIAPHRAGM, PROVIDE 2x FLAT BLOCKING (PER GENERAL STRUCTURAL NOTES) AT ALL UNFRAMED SHEATHING PANEL EDGES.

3. FLOOR FRAMING SHALL BE 15\"/>

TOP CHORD LIVE LOAD	40-psf
TOP CHORD DEAD LOAD	10-psf
BOTTOM CHORD LIVE LOAD	N/A
BOTTOM CHORD DEAD LOAD	5-psf

MAXIMUM LIVE LOAD DEFLECTION SHALL BE THE SMALLER OF L/900 OR 7/8\"/>

LAYOUT SHOWN IS FOR ILLUSTRATIVE PURPOSES ONLY. GIRDER AND BEAM LOCATIONS SHOWN SHALL NOT BE CHANGED WITHOUT APPROVAL FROM THE STRUCTURAL ENGINEER. OTHER FRAMING LAYOUT SHOWN MAY BE MODIFIED TO ACCOMMODATE ACCESS, HVAC OR OTHER FIXTURES.

WALL FRAMING PLAN NOTES:

4. EXTERIOR WALLS SHALL BE SHEAR WALL TYPE P1-5 WITH 2x8 STUDS @ 16\"/>

WHERE ADJACENT SHEAR WALLS ARE IN CONTACT, NAIL STUDS TOGETHER PER 13/S6. SEE 1/S6 FOR SPECIAL STUD REQUIREMENTS AT SHEAR WALL TYPES P1-3, P1-2, P2-4, P2-3, AND P2-2.

5. TOP PLATE ELEVATION SHALL BE PER ARCHITECTURAL DRAWINGS.

6. HEADERS SHALL BE 4x8, U.O.N. SEE DETAIL 19/S6.

7. BUILT-UP STUD GROUPS IN WALLS SUPPORTING BEAMS, POSTS OR GIRDER TRUSSES ABOVE SHALL BE (2) STUDS, U.O.N. SEE GENERAL STRUCTURAL NOTES FOR FASTENING REQUIREMENTS.

LEGEND

- DETAIL CALL-OUT
- SHEAR WALL BELOW PER SCHEDULE OF 1/S6
- BEARING OR SHEAR WALL BELOW
- MUDSILL BELOW
- BEARING OR SHEAR WALL ABOVE
- BLOCK THRU FLOOR FOR POST ABOVE (MATCH AREA)
- POST BELOW
- FLUSH FRAMED (BOTTOM FLUSH W/ BOTTOM OF FRAMING)
- HDR HEADER PER PLAN NOTE 5

LOWER WALL/MAIN FLOOR FRAMING PLAN

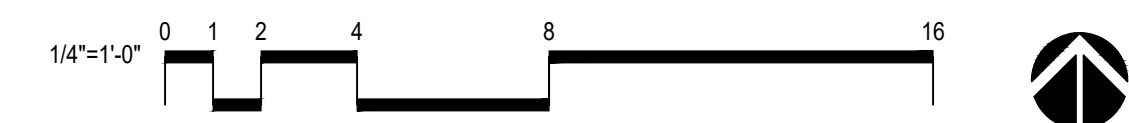

PERMIT	3/3/2024
PERMIT UPDATE	10/1/2024
PLAN REVIEW	01/09/2025
PLAN REVIEW 2	04/17/2025

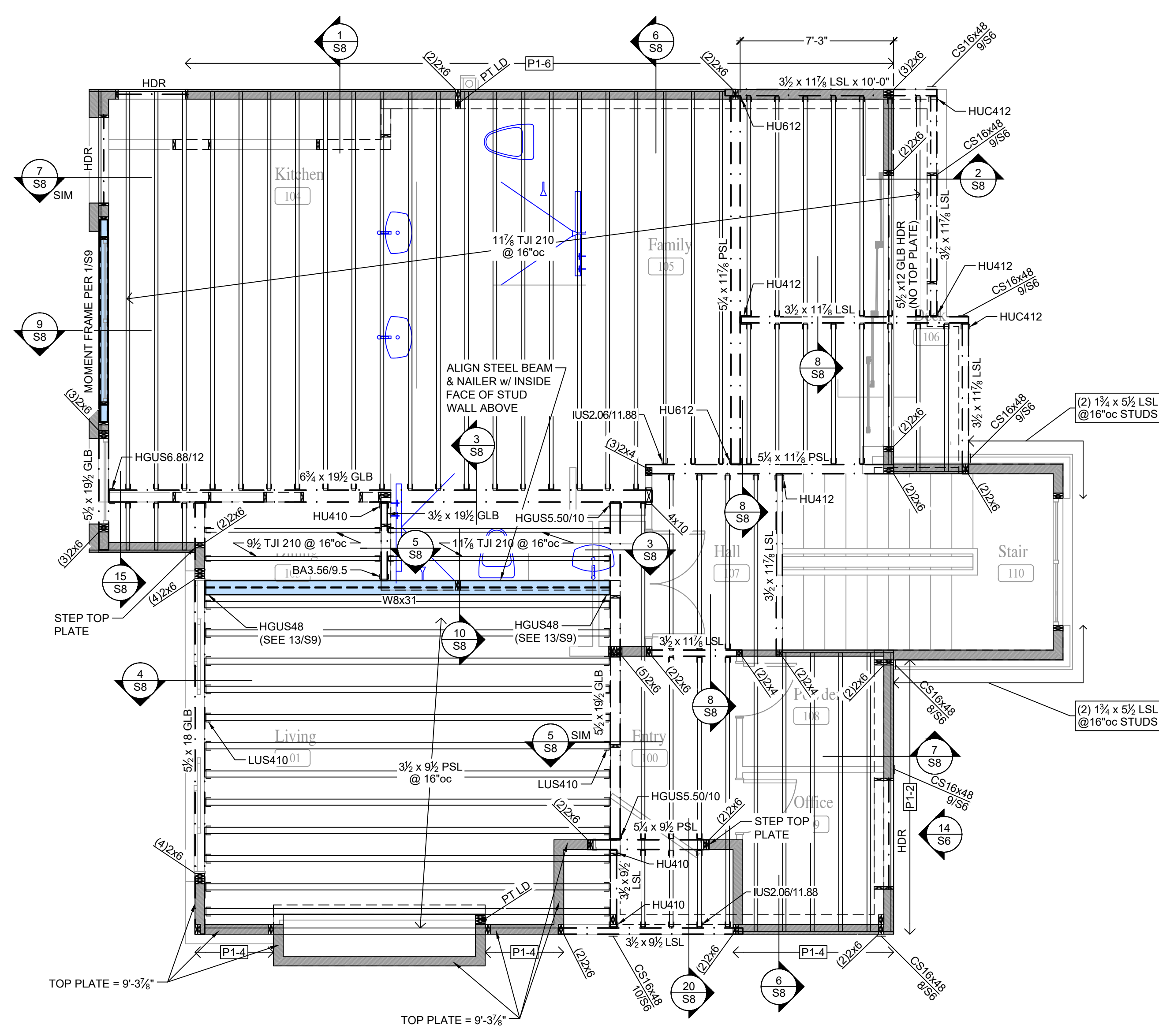

FLOOR FRAMING PLAN NOTES:
 1. FLOOR SHEATHING SHALL BE 1/2" THICK T&G (SINGLE FLOOR PANEL SPAN RATING 48" OC). GLUE SHEATHING TO ALL FRAMING MEMBERS AND BLOCKING BELOW WITH ADHESIVE CONFORMING TO A.P.A SPECIFICATION AFG-01. FASTEN SHEATHING TO FRAMING WITH WSV212 SUBFLOOR SCREWS (#9 x 2") or 0.131"Ø x 2 1/2" NAILS AS FOLLOWS:

FRAMING, EDGES	6"OC
FRAMING, EDGES @ BLOCKED DIAPHRAGM	4"OC
FRAMING, FIELD	10"OC
BOUNDARIES, BLOCKING, STRUTS	6"OC

AT AREAS INDICATED AS BLOCKED DIAPHRAGM, PROVIDE 2x FLAT BLOCKING (PER GENERAL STRUCTURAL NOTES) AT ALL UNFRAMED SHEATHING PANEL EDGES. FASTEN SHEATHING TO FRAMING AND BLOCKING WITH WSV212 SUBFLOOR SCREWS (#9 x 2 1/2") or 0.131"Ø x 2 1/2" NAILS AS FOLLOWS:

SEE DRAWINGS FOR OTHER SHEATHING NAILING REQUIREMENTS.

2. FLOOR JOISTS SHALL BE 1 1/4" TJI 210 @ 16"OC, U.O.N.
 LAYOUT SHOWN IS FOR ILLUSTRATIVE PURPOSES ONLY. GIRDER AND BEAM LOCATIONS SHOWN SHALL NOT BE CHANGED WITHOUT APPROVAL FROM THE STRUCTURAL ENGINEER. OTHER FRAMING LAYOUT SHOWN MAY BE MODIFIED TO ACCOMMODATE ACCESS, HVAC OR OTHER FIXTURES.

WALL FRAMING PLAN NOTES:
 3. EXTERIOR WALLS SHALL BE SHEAR WALL TYPE P1-6 WITH 2x6 STUDS @ 16"OC, U.O.N.
 INTERIOR WALLS SHALL BE 2x4 STUDS @ 16"OC, U.O.N.

WHERE ADJACENT SHEAR WALLS ARE IN CONTACT, NAIL STUDS TOGETHER PER 13/16. SEE 1/16 FOR SPECIAL STUD REQUIREMENTS AT SHEAR WALL TYPES P1-3, P1-2, P2-4, P2-3, AND P2-2.

- 4. TOP PLATE ELEVATION SHALL BE 10'-0" U.O.N.
- 5. HEADERS SHALL BE 3/2" x 9", U.O.N. SEE DETAIL 19/S6.
- 6. BUILT-UP STUD GROUPS IN WALLS SUPPORTING BEAMS, POSTS OR GIRDER TRUSSES ABOVE SHALL BE (2) STUDS, U.O.N. SEE GENERAL STRUCTURAL NOTES FOR FASTENING REQUIREMENTS.

LEGEND

- DETAIL CALL-OUT
- SHEAR WALL BELOW PER SCHEDULE OF 1/S6
- BEARING OR SHEAR WALL BELOW
- BEARING OR SHEAR WALL ABOVE
- BLOCK THRU FLOOR FOR POST ABOVE (MATCH AREA)
- POST BELOW
- FLUSH FRAMED (BOTTOM FLUSH W/ BOTTOM OF FRAMING)
- HEADER PER PLAN NOTE 5

MAIN WALL/UPPER FLOOR FRAMING PLAN

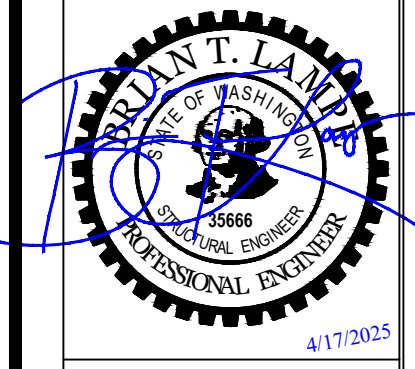
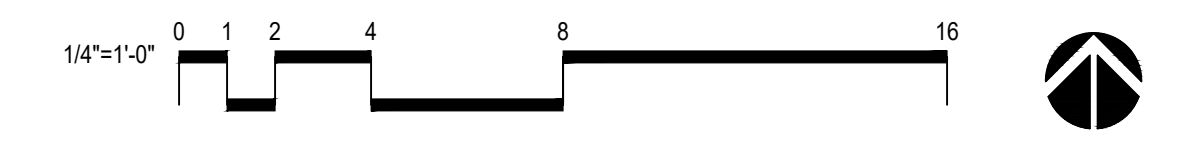

PERMIT	3/3/2024
PERMIT UPDATE	10/1/2024
PLAN REVIEW	01/09/2025
PLAN REVIEW 2	04/17/2025

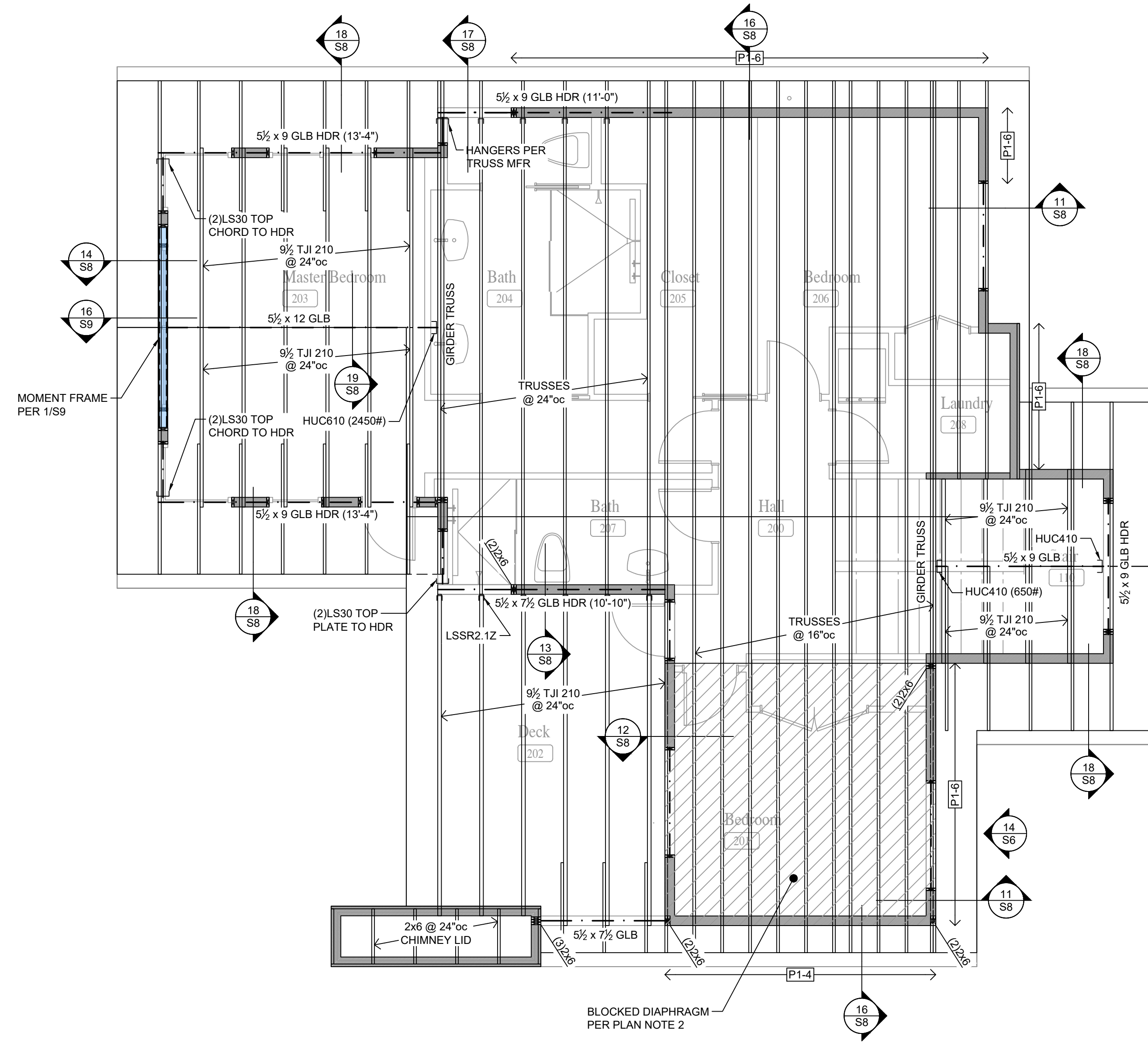

ROOF FRAMING PLAN NOTES:

- ROOF SHEATHING SHALL BE 3/4" THICK (PANEL SPAN RATING 32/16). FASTEN SHEATHING TO FRAMING WITH 0.1317" x 2 1/2" NAILS AS FOLLOWS:

FRAMING EDGES	6"oc
FRAMING FIELD	12"oc
BOUNDARIES, BLOCKING, STRUTS	6"oc

AT UNFRAMED PANEL EDGES, PROVIDE PSCA FRAMING CLIPS CENTERED BETWEEN EACH FRAMING MEMBER. SEE DRAWINGS FOR OTHER SHEATHING NAILING REQUIREMENTS.

- AT AREAS INDICATED AS BLOCKED DIAPHRAGM, PROVIDE 2x FLAT BLOCKING (PER GENERAL STRUCTURAL NOTES) AT ALL UNFRAMED SHEATHING PANEL EDGES.

- ROOF FRAMING SHALL BE CONNECTOR PLATE TRUSSES. U.O.N. LOADING SHALL BE AS FOLLOWS:

TOP CHORD SNOW LOAD	25-psf
TOP CHORD DEAD LOAD	10-psf
BOTTOM CHORD LIVE LOAD	N/A
BOTTOM CHORD DEAD LOAD	5-psf

LAYOUT SHOWN IS FOR ILLUSTRATIVE PURPOSES ONLY. GIRDER AND BEAM LOCATIONS SHOWN SHALL NOT BE CHANGED WITHOUT APPROVAL FROM THE STRUCTURAL ENGINEER. OTHER FRAMING LAYOUT SHOWN MAY BE MODIFIED TO ACCOMMODATE ATTIC ACCESS, SKYLIGHTS, HVAC OR OTHER FIXTURES.

WALL FRAMING PLAN NOTES:

- EXTERIOR WALLS SHALL BE SHEAR WALL TYPE P1-6 WITH 2x6 STUDS @ 16"oc, U.O.N. INTERIOR WALLS SHALL BE 2x4 STUDS @ 16"oc, U.O.N.

WHERE ADJACENT SHEAR WALLS ARE IN CONTACT, NAIL STUDS TOGETHER PER 13/S6. SEE 1/S6 FOR SPECIAL STUD REQUIREMENTS AT SHEAR WALL TYPES P1-3, P1-2, P2-4, P2-3, AND P2-2.

- TOP PLATE ELEVATION SHALL BE 8'-10 1/2" U.O.N.
- HEADERS SHALL BE 5 1/2 x 7 1/2 GLB, U.O.N. T.O. HEADER ELEVATION SHALL BE 9'-3", U.O.N. SEE DETAIL 20/S6. NO HEADERS @ GABLE ENDS. DO NOT SPLICE TOP CHORD @ OPENINGS.
- BUILT-UP STUD GROUPS IN WALLS SUPPORTING BEAMS, POSTS OR GIRDER TRUSSES ABOVE SHALL BE (2) STUDS, U.O.N. SEE GENERAL STRUCTURAL NOTES FOR FASTENING REQUIREMENTS.

LEGEND

- DETAIL CALL-OUT
- SHEAR WALL BELOW PER SCHEDULE OF 1/S6
- BEARING OR SHEAR WALL BELOW
- POST BELOW
- (F) FLUSH FRAMED (BOTTOM FLUSH W/ BOTTOM OF FRAMING)
- HDR HEADER PER PLAN NOTE 5

UPPER WALL/ROOF FRAMING PLAN

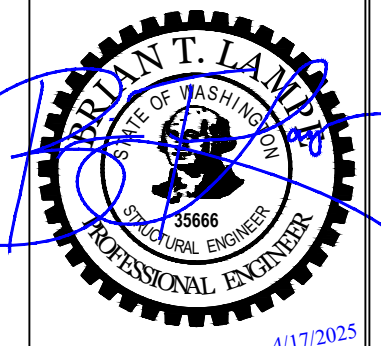
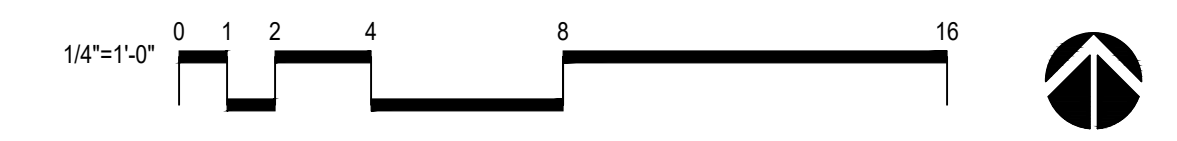

PERMIT	3/3/2024
PERMIT UPDATE	10/1/2024
PLAN REVIEW	01/09/2025
PLAN REVIEW 2	04/17/2025

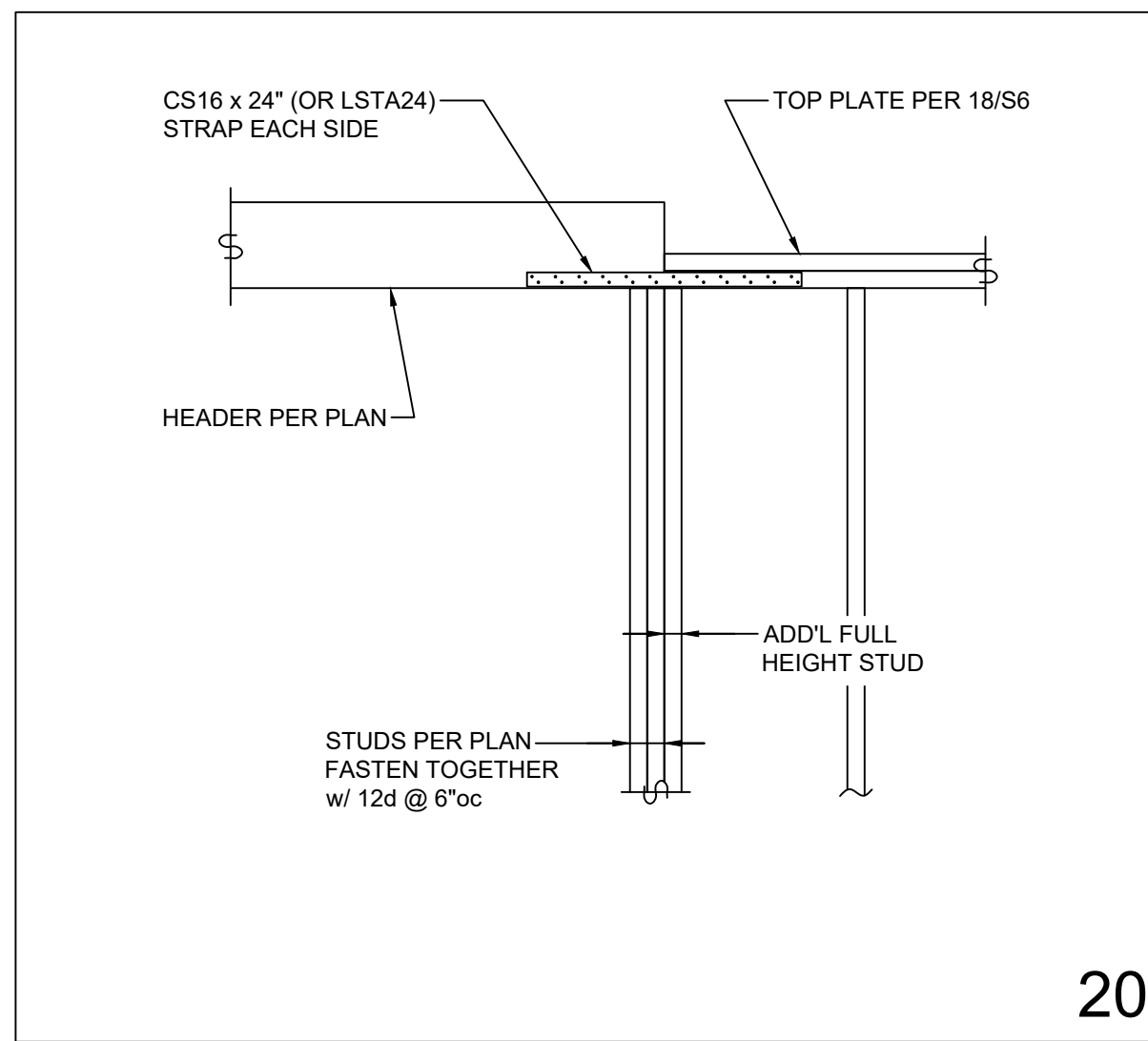

20

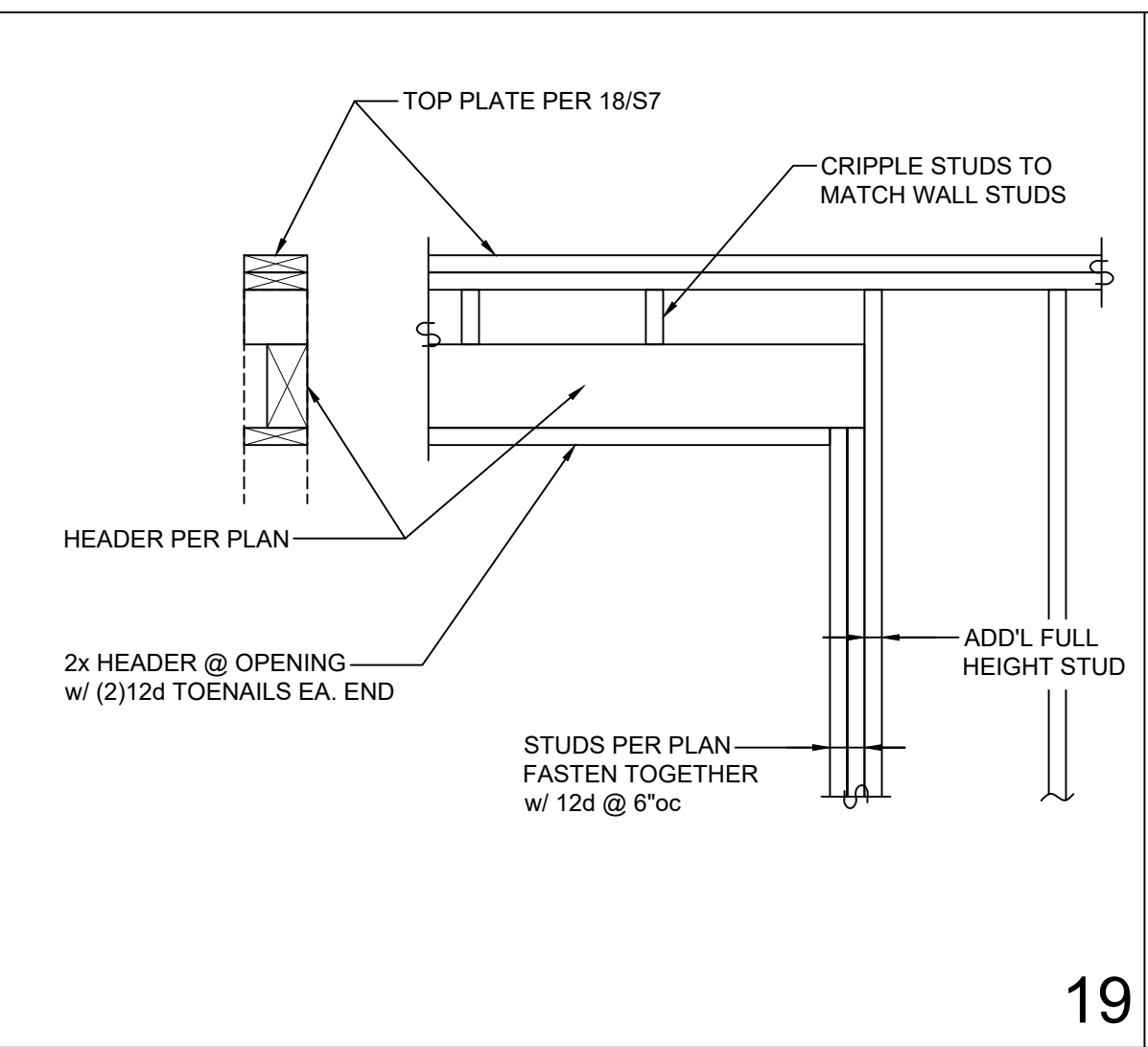

19

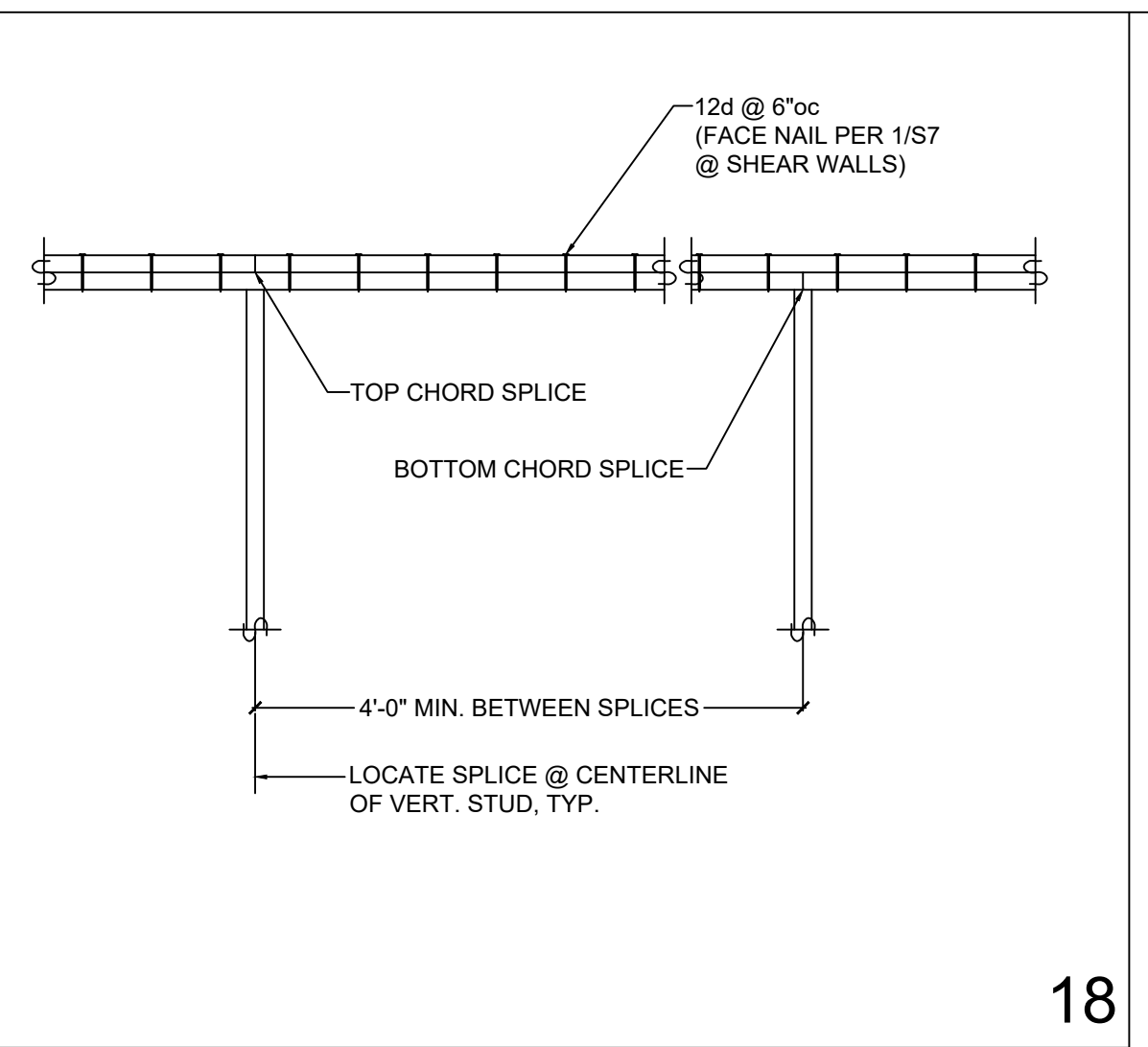

18

SHEAR WALL SCHEDULE
(IN ACCORDANCE W/ ANSI/AF&PA SDPWS-2021 SECTION 4.3)
Updated 4/1/2024

WALL TYPE	SHEATHING (1)	PANEL EDGE NAILING (2)	MINIMUM WIDTH OF NAILED FACE OF FRAMING @ ADJOINING PANEL EDGES (3)		MUDSILL PLATE	FACE NAILING (4)	FRAMING CLIPS (5)	ANCHORAGE TO CONCRETE (6)		SEISMIC CAPACITY h/b = 2 h/b = 3.5	WIND CAPACITY h/b = 2 h/b = 3.5
			SINGLE MEMBER	BUILT-UP MEMBER				ANCHOR BOLTS	MUDSILL ANCHORS		
P1-6	1 SIDE	6" oc	2x	2x	2x	6" oc	A35 @ 28" oc or LTP4 @ 28" oc	5/8" @ 60" oc	MASAP @ 52" oc	240-pf 194-pf	240-pf 194-pf
P1-4	1 SIDE	4" oc	2x	2x	2x	4" oc	A35 @ 19" oc or LTP4 @ 19" oc	5/8" @ 46" oc	MASAP @ 36" oc	350-pf 284-pf	350-pf 284-pf
P1-3	1 SIDE	3" oc	3x	(2)2x	2x	3" oc	A35 @ 14" oc or LTP4 @ 14" oc	5/8" @ 36" oc	MASAP @ 28" oc	450-pf 366-pf	450-pf 366-pf
P1-2	1 SIDE	2" oc	3x	(2)2x	2x	2" oc	A35 @ 8" oc or LTP4 @ 8" oc	5/8" @ 20" oc	MASAP @ 18" oc	590-pf 478-pf	820-pf 669-pf
P2-2	2 SIDES	2" oc	3x	(2)2x	3x	(2) Rows, 2" oc	A35 @ 8" oc and LTP4 @ 8" oc	5/8" @ 12" oc	MASAP @ 7" oc	1180-pf 957-pf	1640-pf 1338-pf

SHEAR WALL SCHEDULE NOTES
 (1) SECTION 4.3.7.1.1
 1/2" OSB or 5/8" PLYWOOD SHEATHING OR SIDING EXCEPT GROUP 5 SPECIES. MINIMUM PANEL SPAN RATING OF (2/4)0. PANELS SHALL NOT BE LESS THAN 4'x8', EXCEPT AT BOUNDARIES AND CHANGES IN FRAMING. ALL EDGES OF ALL PANELS SHALL BE SUPPORTED BY AND FASTENED TO FRAMING MEMBERS OR BLOCKING.
 (2) SECTION 4.3.7.1.2 & SECTION 4.3.7.1.3
 PANEL EDGE NAILING APPLIES TO ALL SHEATHING PANEL EDGES. NAIL SHEATHING TO INTERMEDIATE FRAMING MEMBERS WITH SHEATHING NAILS @ 12" oc. MAXIMUM STUD SPACING SHALL BE 16" oc. SHEATHING NAILS SHALL BE 0.131"Ø x 2 1/2". PLYWOOD EDGE NAILING SHALL BE STAGGERED. NAILS SHALL BE LOCATED AT LEAST 3/8" FROM THE PANEL EDGES.

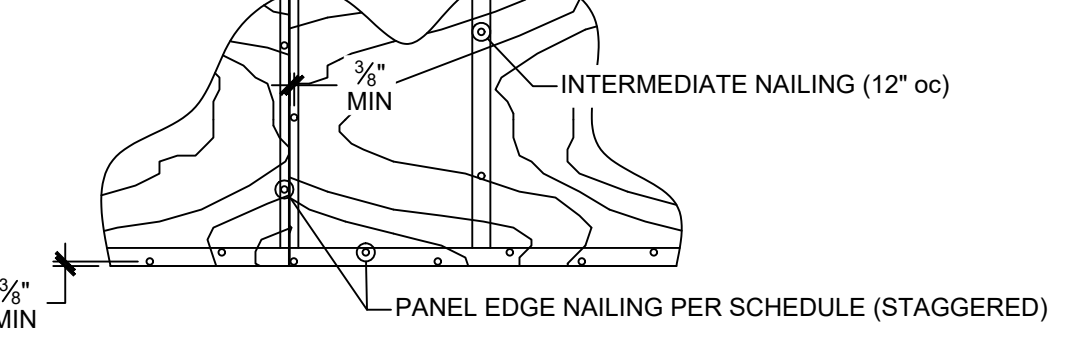

(3) SECTION 4.3.7.1.4
 THE MINIMUM NOMINAL WIDTH OF THE NAILED FACE OF FRAMING AND BLOCKING AT ADJOINING PANEL EDGES SHALL BE AS INDICATED IN THE SCHEDULE.

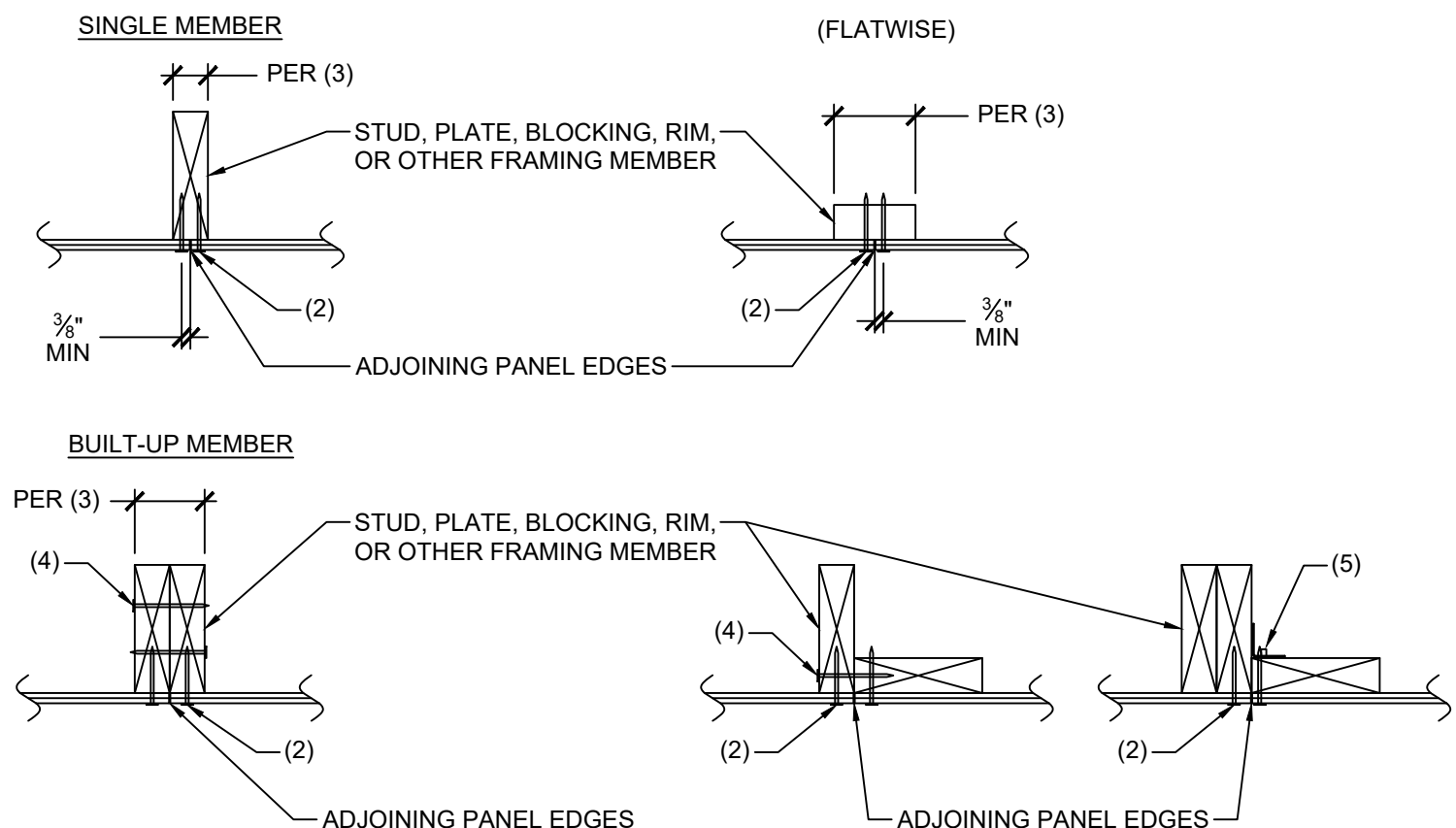

(4) FACE NAILING APPLIES TO CONDITIONS WHERE FRAMING NAILS CAN BE STRAIGHT DRIVEN THRU FIRST MEMBER AND PENETRATE MAIN MEMBER MINIMUM OF 1 1/2". FRAMING NAILS SHALL BE 0.131"Ø x 3 1/4". 0.131"Ø x 3" NAILS MAY BE USED WHEN STITCHING TOGETHER (2)2x MEMBERS WITH NO SPACERS.
 (5) AT ADJOINING PANEL EDGES WHERE SHEATHING CANNOT LAP ON SINGLE MEMBER AND FACE NAILING CANNOT BE ACCOMPLISHED, FRAMING CLIPS SHALL BE USED TO FASTEN BUILT-UP MEMBERS. USE 0.131"Ø x 2 1/2" NAILS AT LTP4 CLIP WHEN INSTALLED OVER 1/2" SHEATHING.

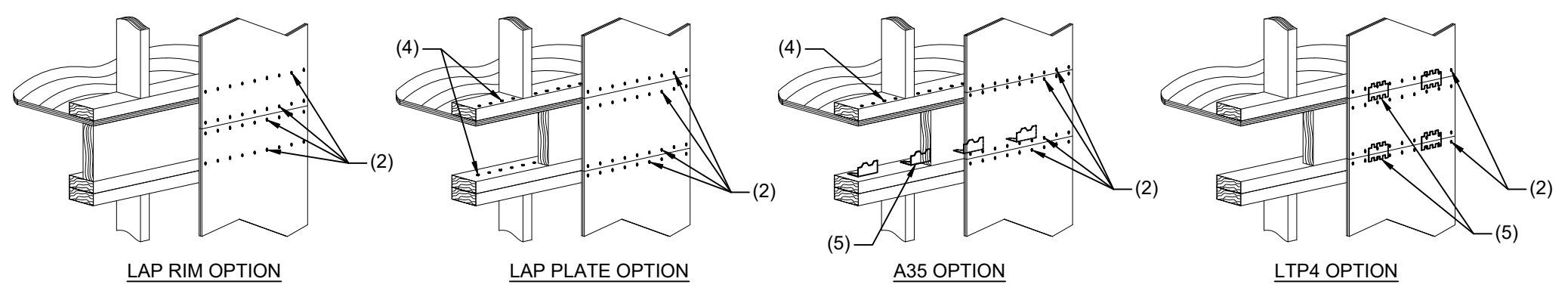

(6) SECTION 4.3.6.4.3
 ANCHOR BOLTS EMBEDMENT SHALL BE 7". U.O.N. ALL ANCHORS SHALL HAVE 3" x 3" x 0.229" PLATE WASHERS. PLATE WASHER SHALL EXTEND TO WITHIN 1/2" OF THE EDGE OF THE BOTTOM PLATE ON THE SIDE WITH SHEATHING. IF SHEATHING IS ON BOTH SIDES OF THE WALL, STAGGER THE ANCHOR BOLTS, AS REQUIRED, SO THAT HALF OF THE PLATE WASHERS ARE WITHIN 1/2" OF THE EDGE OF THE BOTTOM PLATE ON EACH SIDE. HOLE IN PLATE WASHERS MAY BE DIAGONALLY SLOTTED.

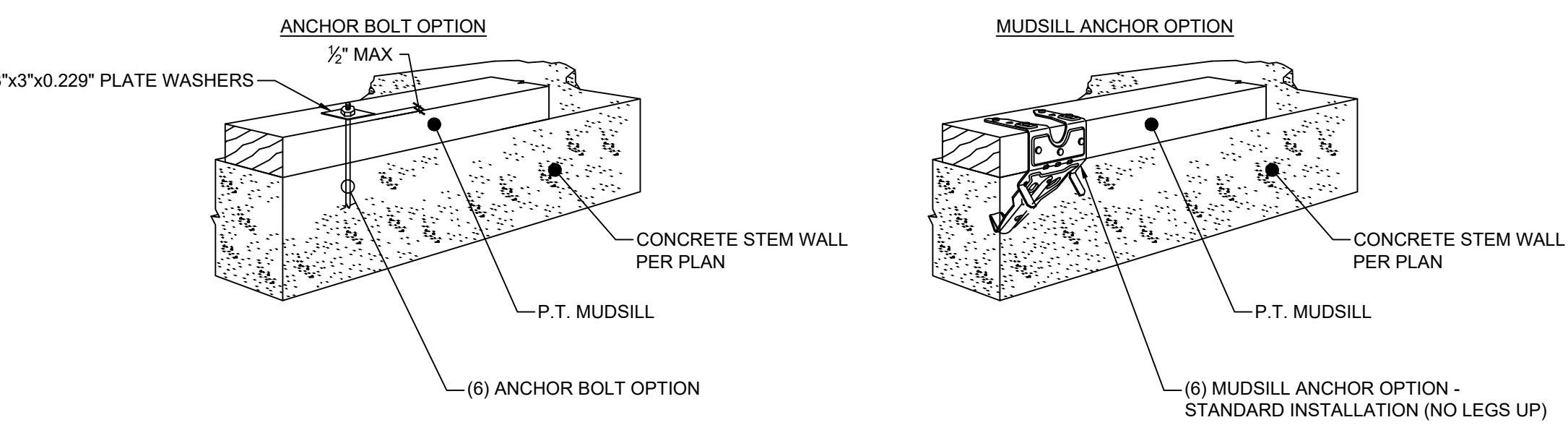

15

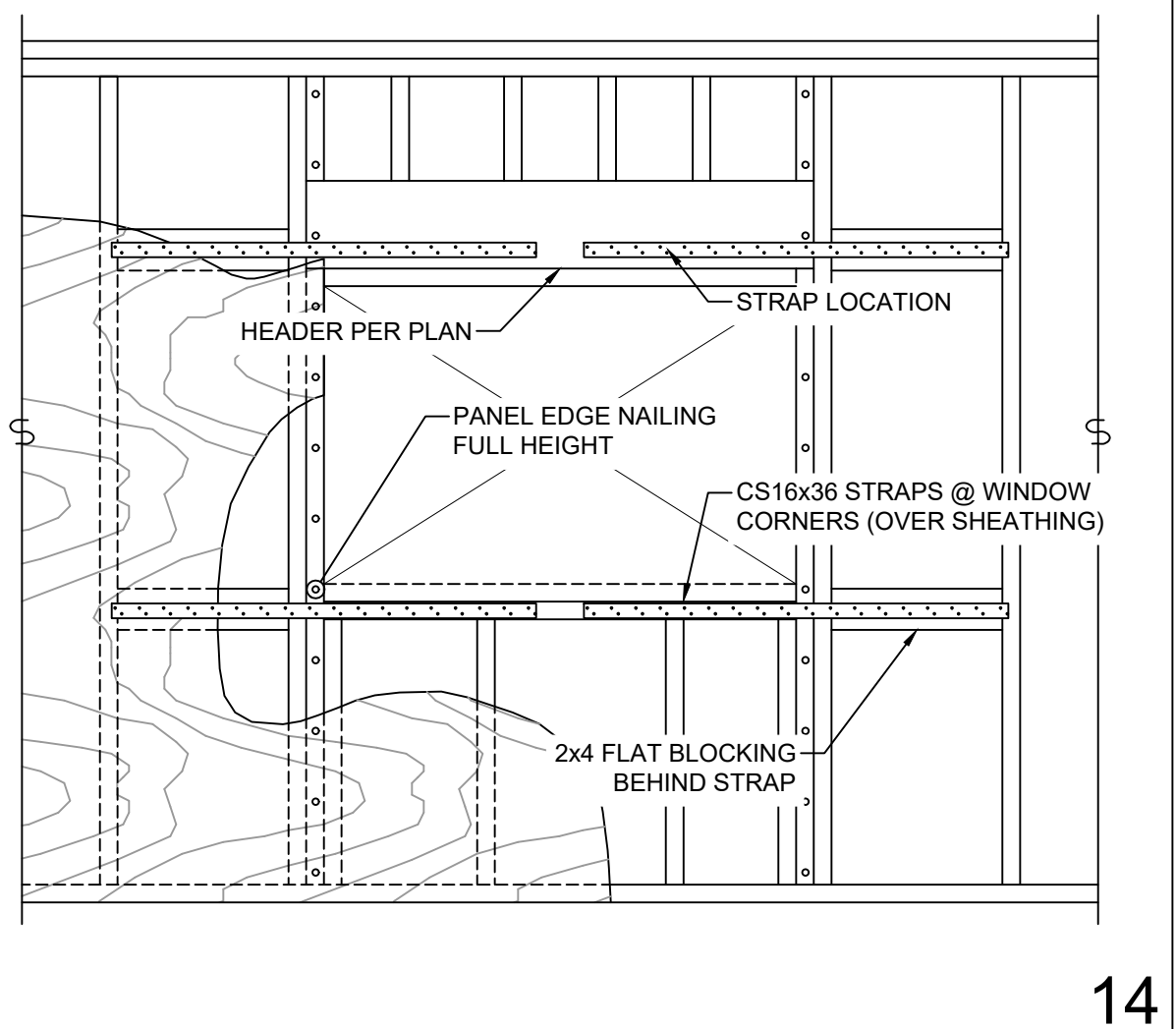

14

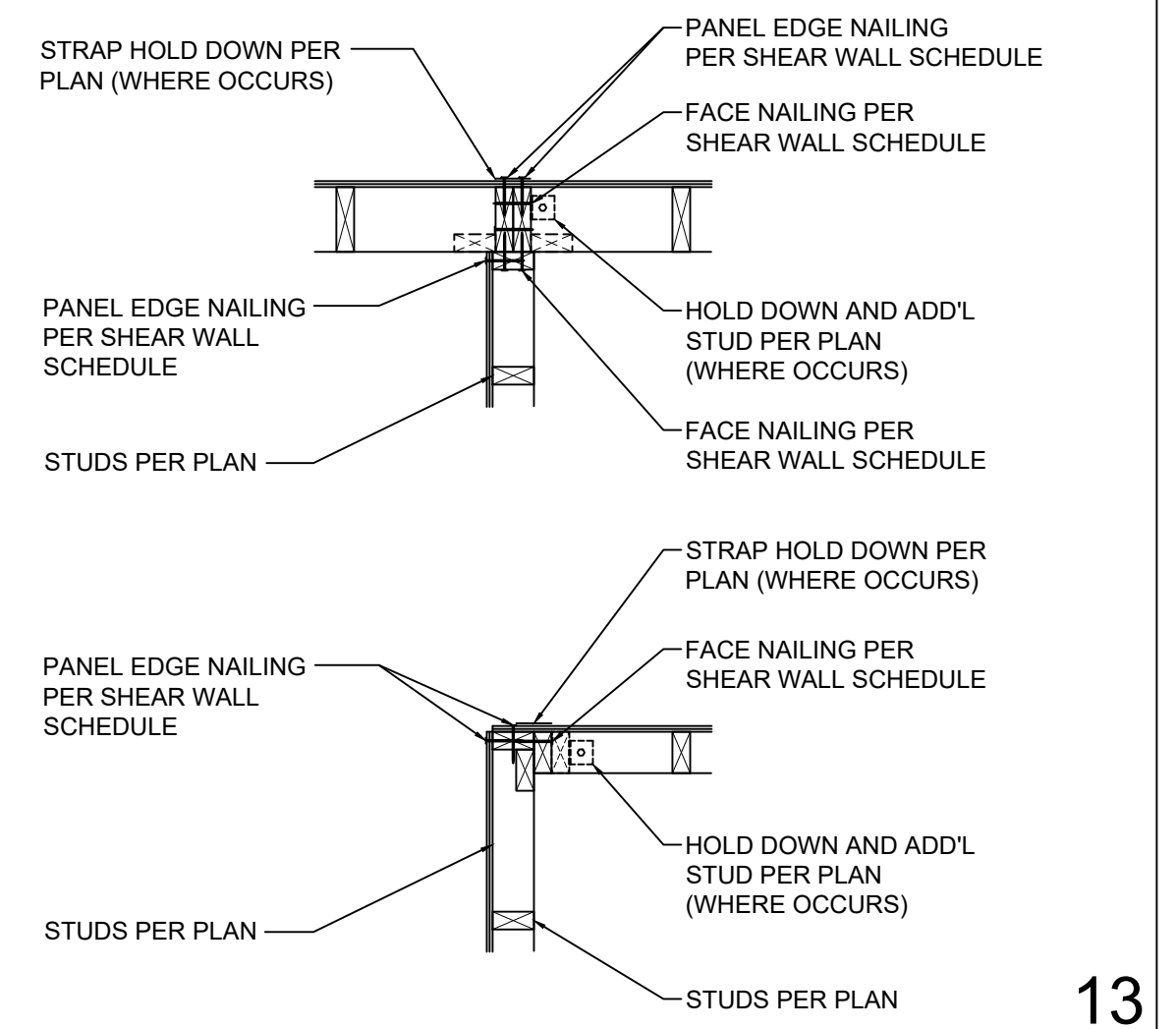

13

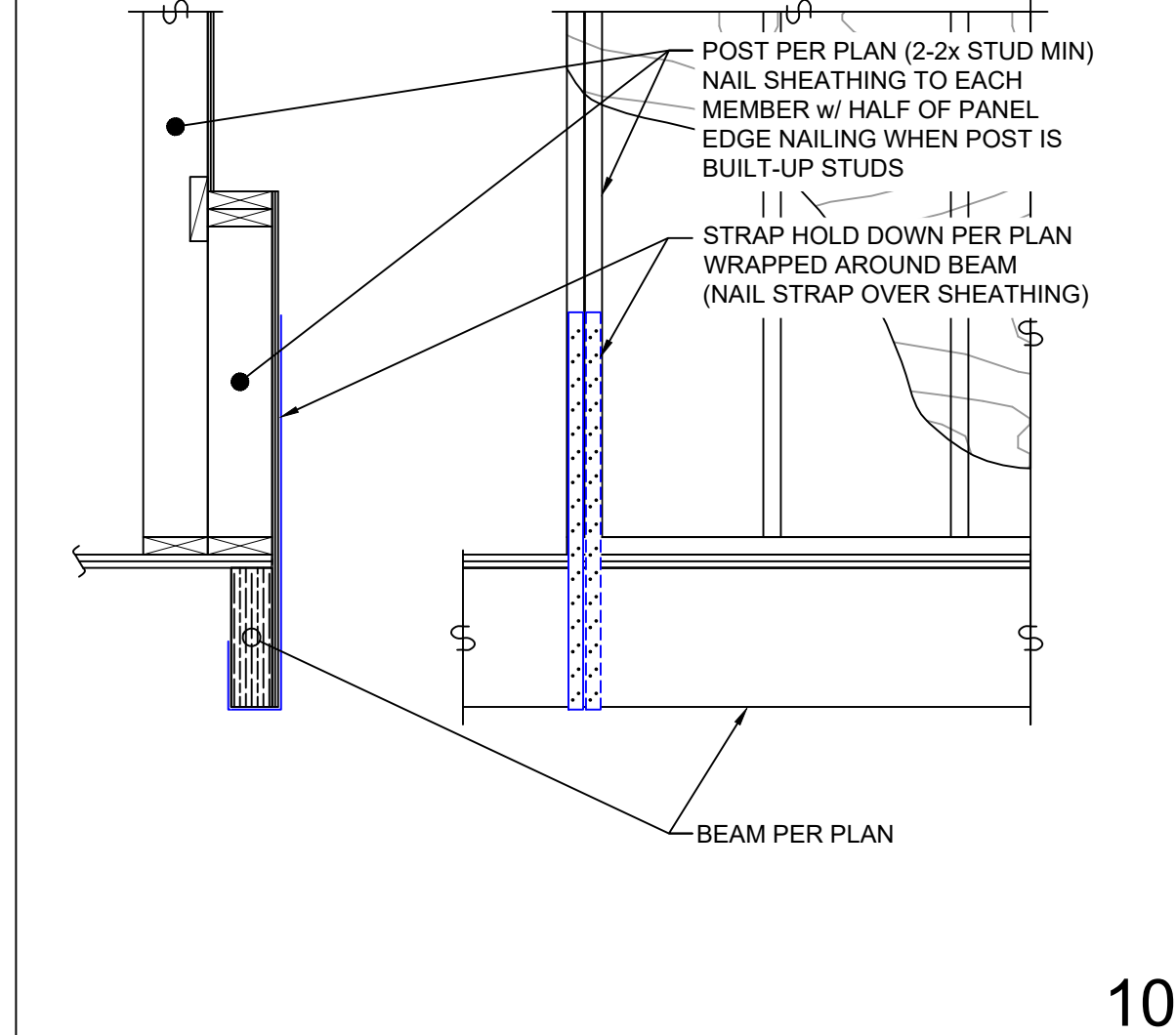

10

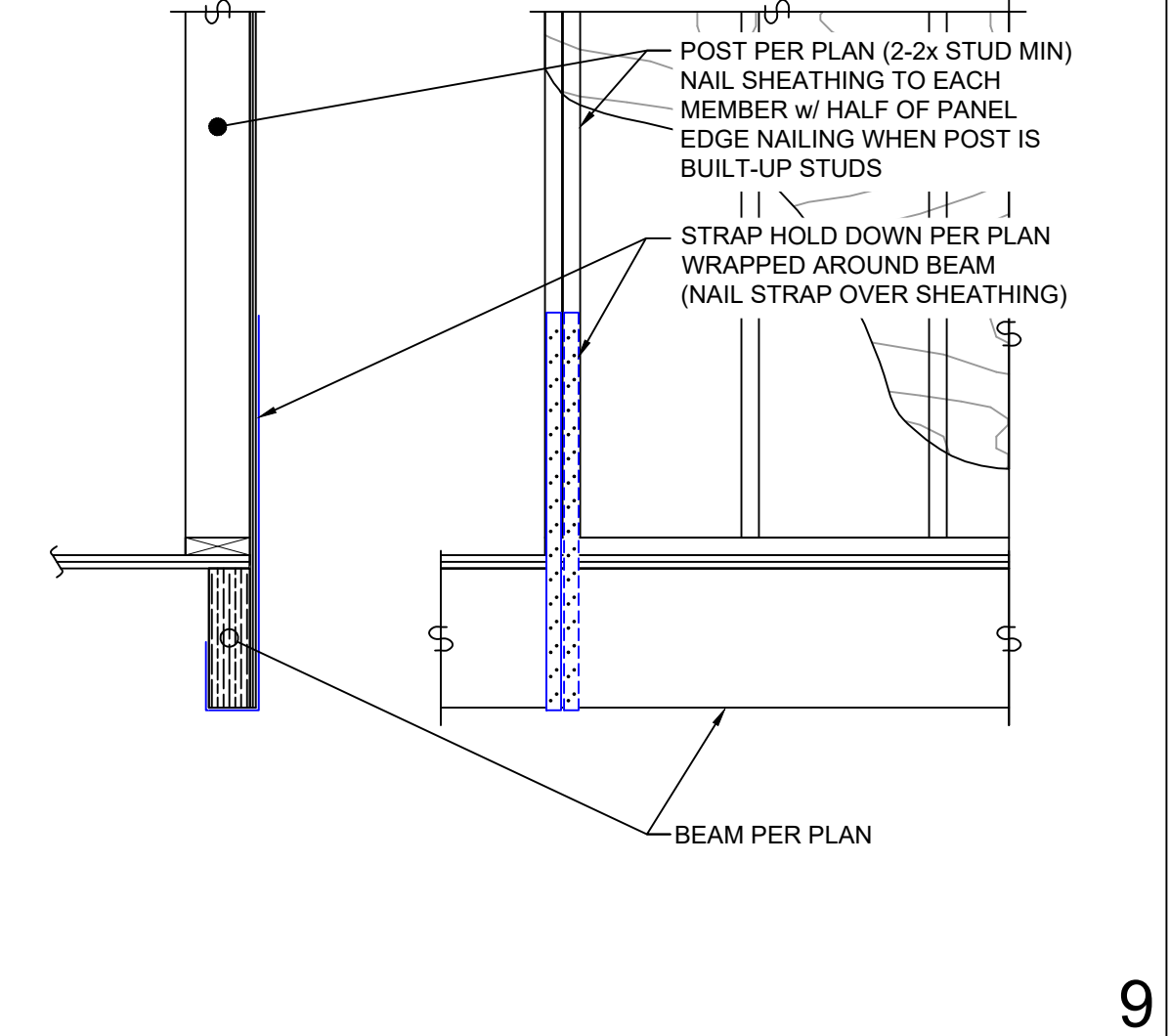

9

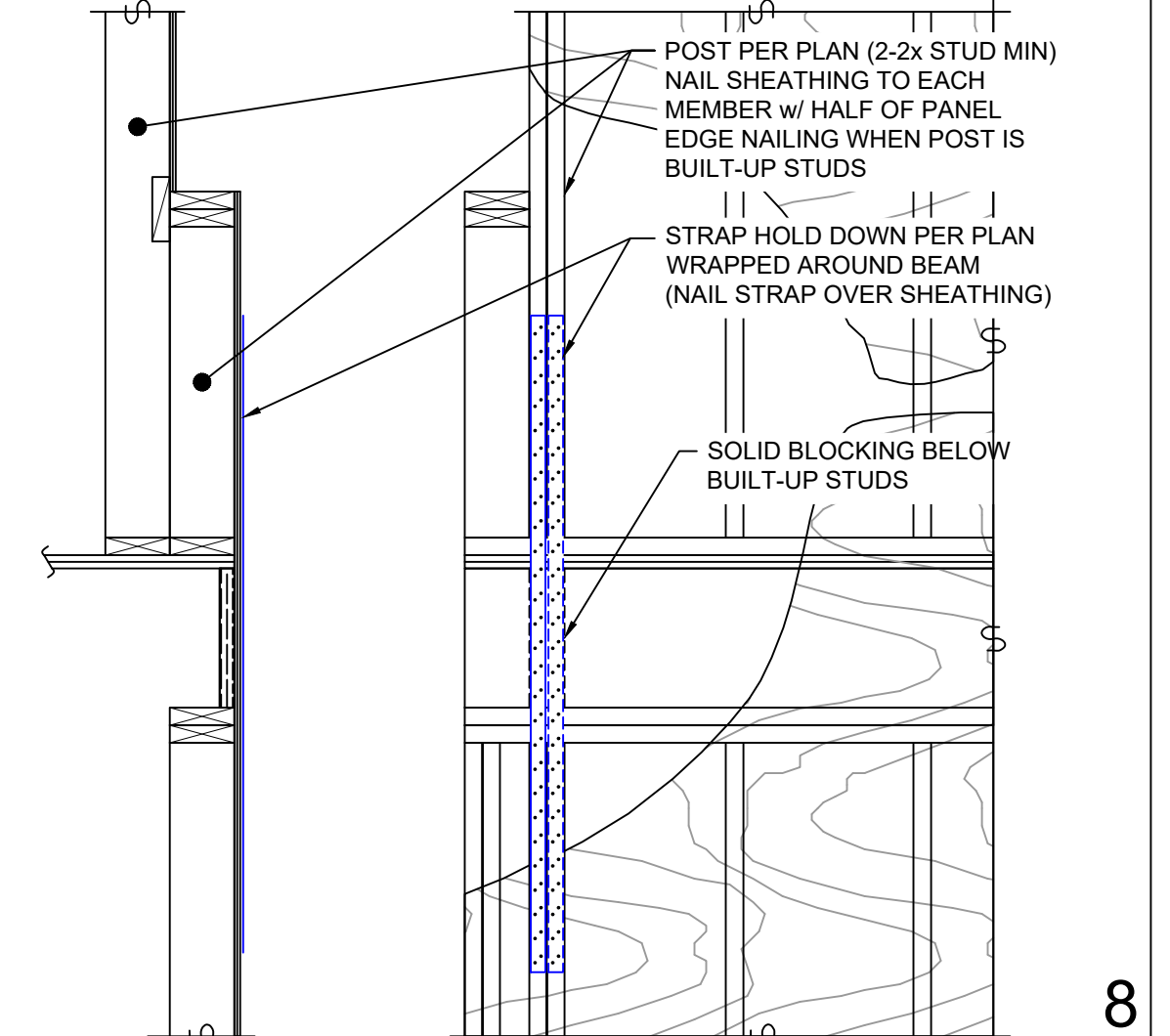

8

PLAN CALLOUT	SIZE	REINFORCING	DETAIL REFERENCE
18	18" sq x 8" thick	(2)#4 EA. WAY BOTTOM	-
24	24" sq x 8" thick	(2)#4 EA. WAY BOTTOM	-
30	30" sq x 8" thick	(3)#4 EA. WAY BOTTOM	-
36	36" sq x 12" thick	(3)#4 EA. WAY BOTTOM	-
42	42" sq x 12" thick	(4)#4 EA. WAY BOTTOM	-
48	48" sq x 12" thick	(5) #4 EA. WAY BOTTOM	-

5

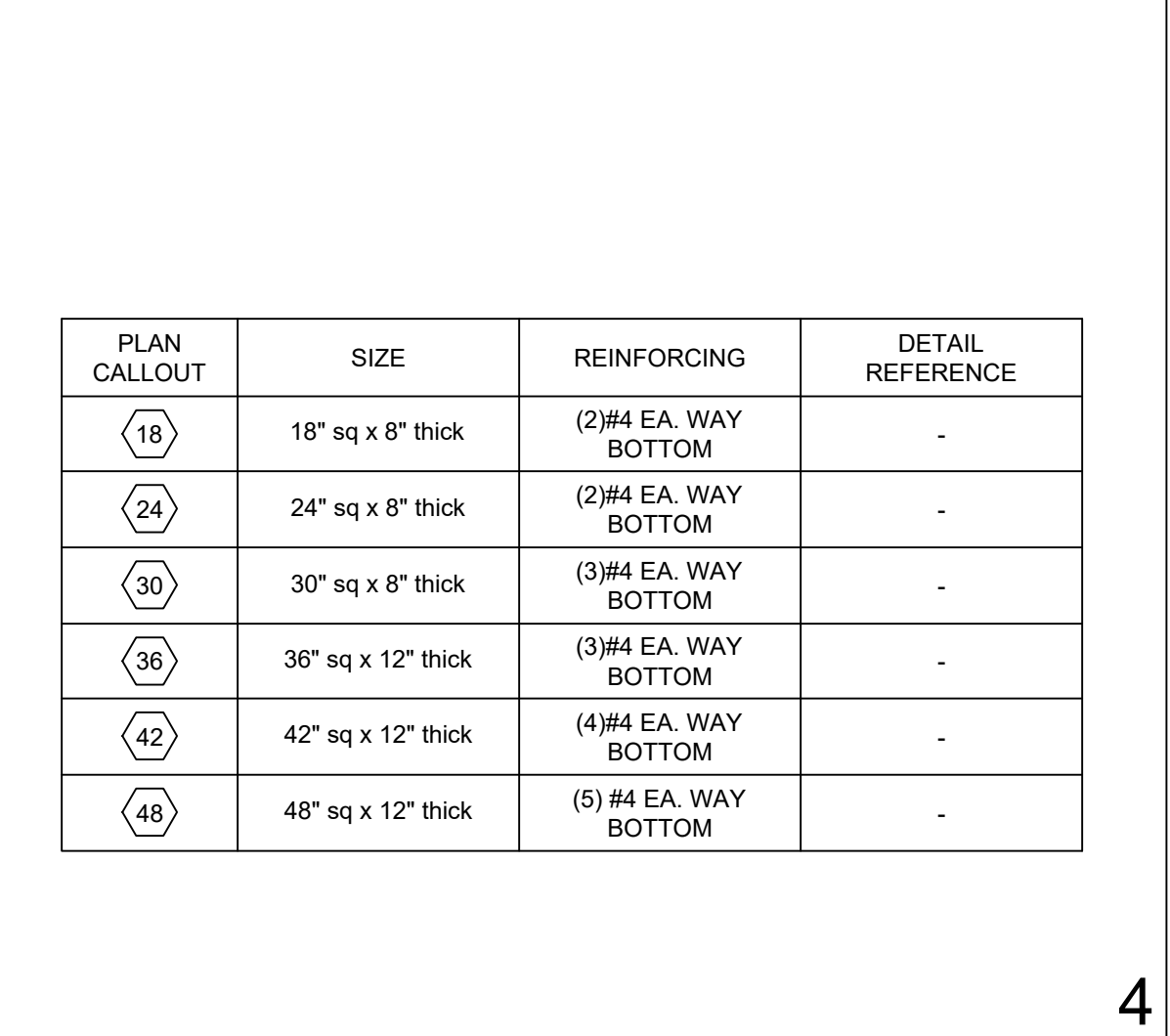

4

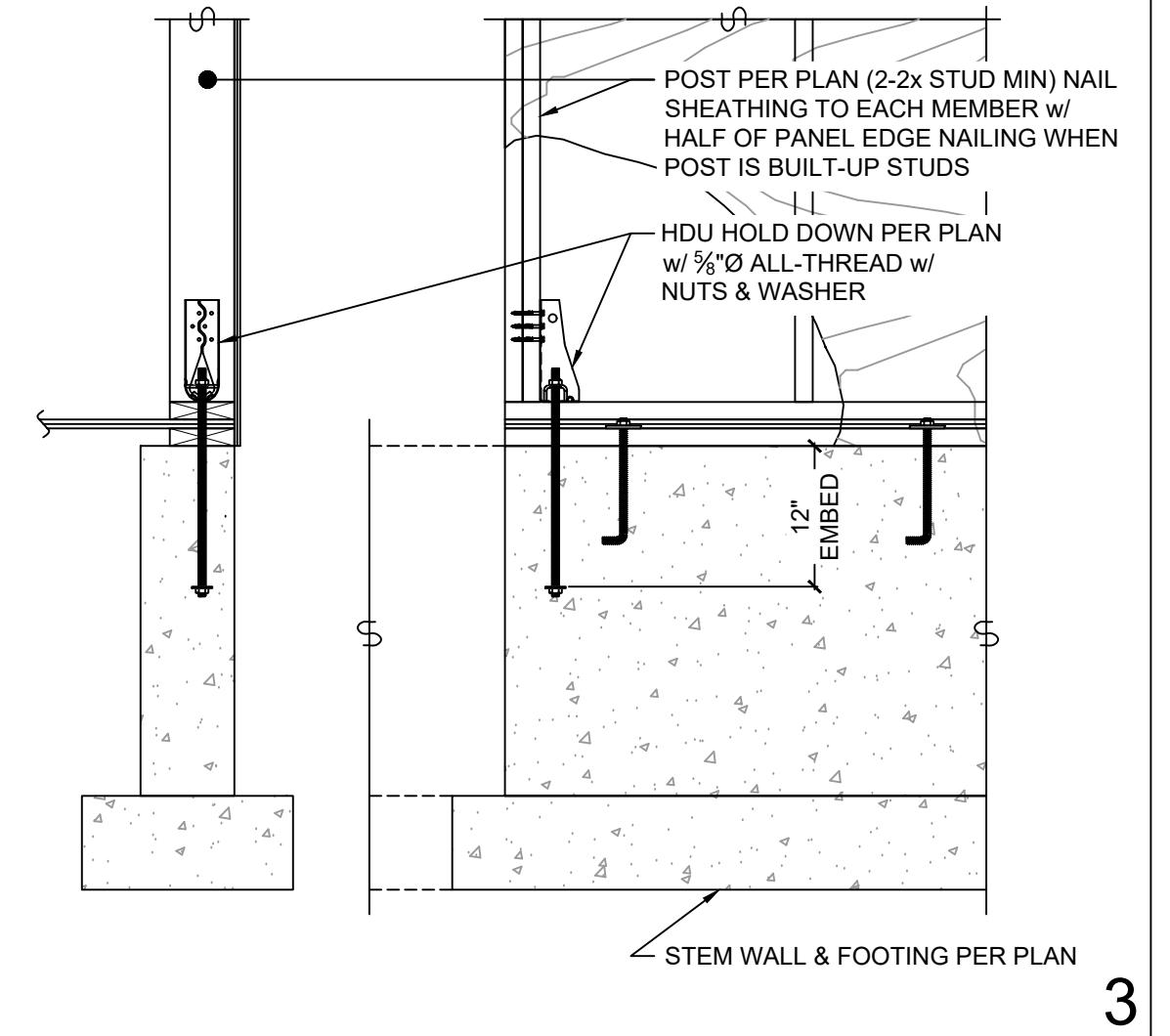

3

(6) ANCHOR BOLT OPTION
 (6) MUDSILL ANCHOR OPTION - STANDARD INSTALLATION (NO LEGS UP)

1

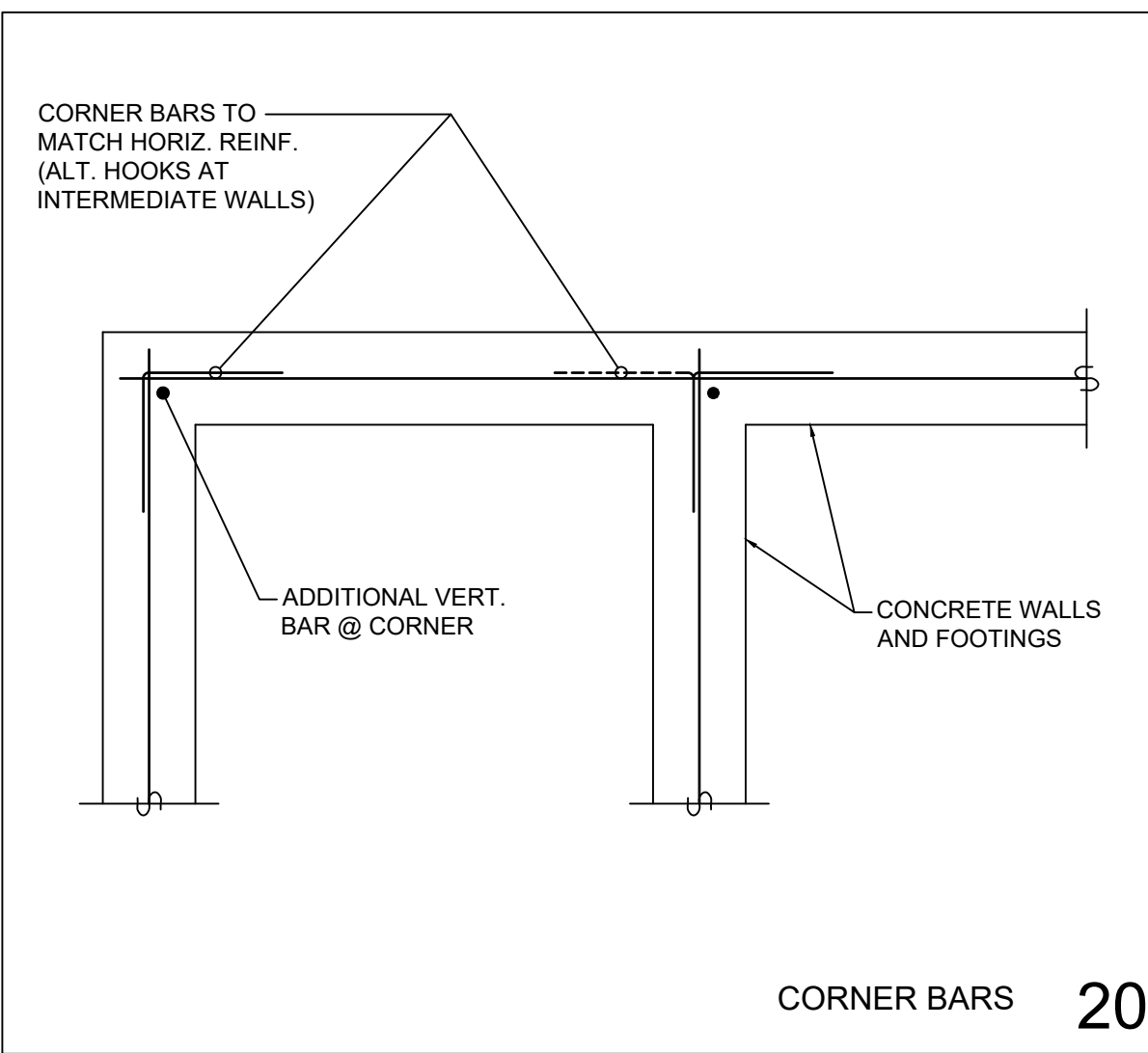

CORNER BARS 20

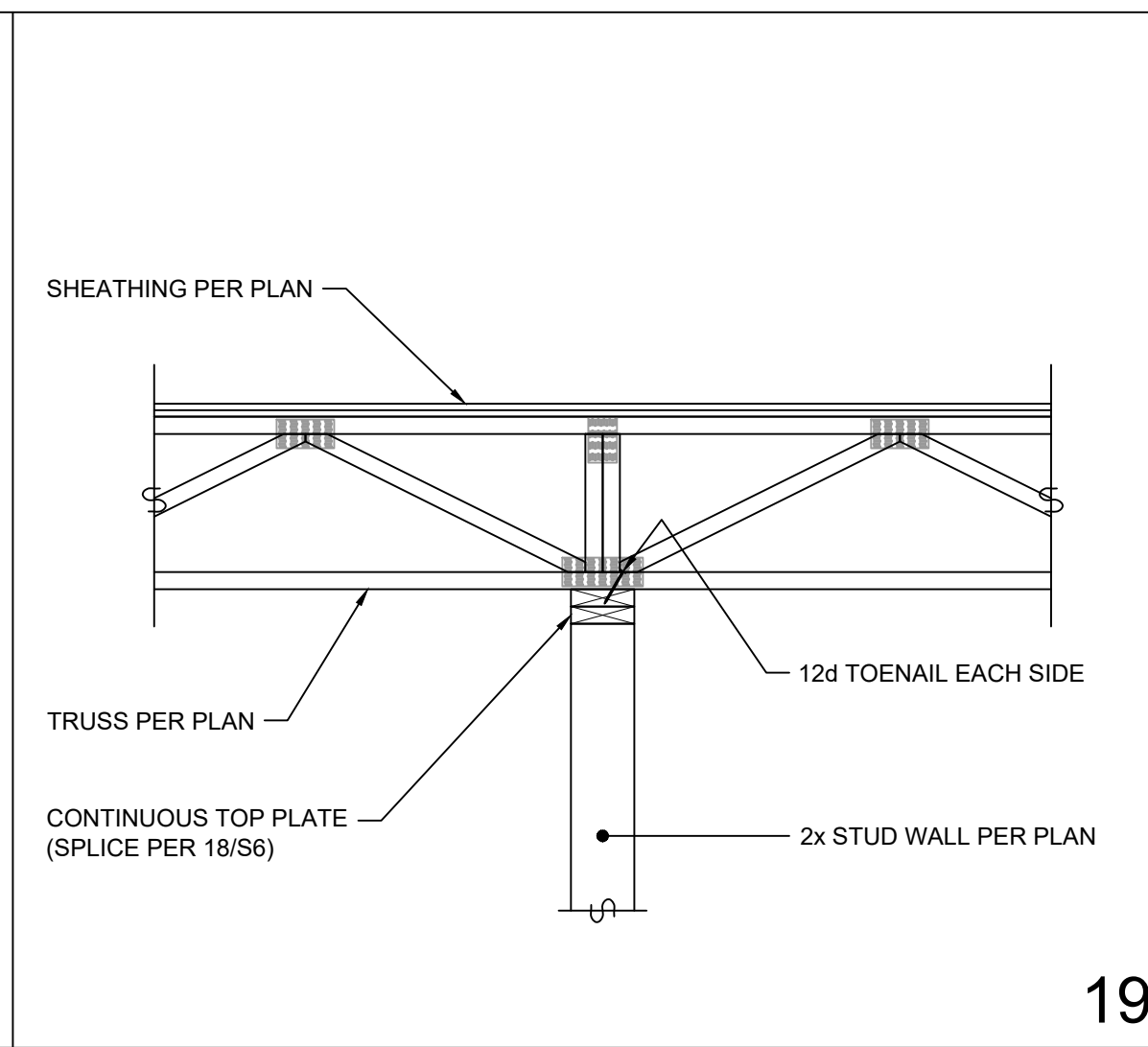

19

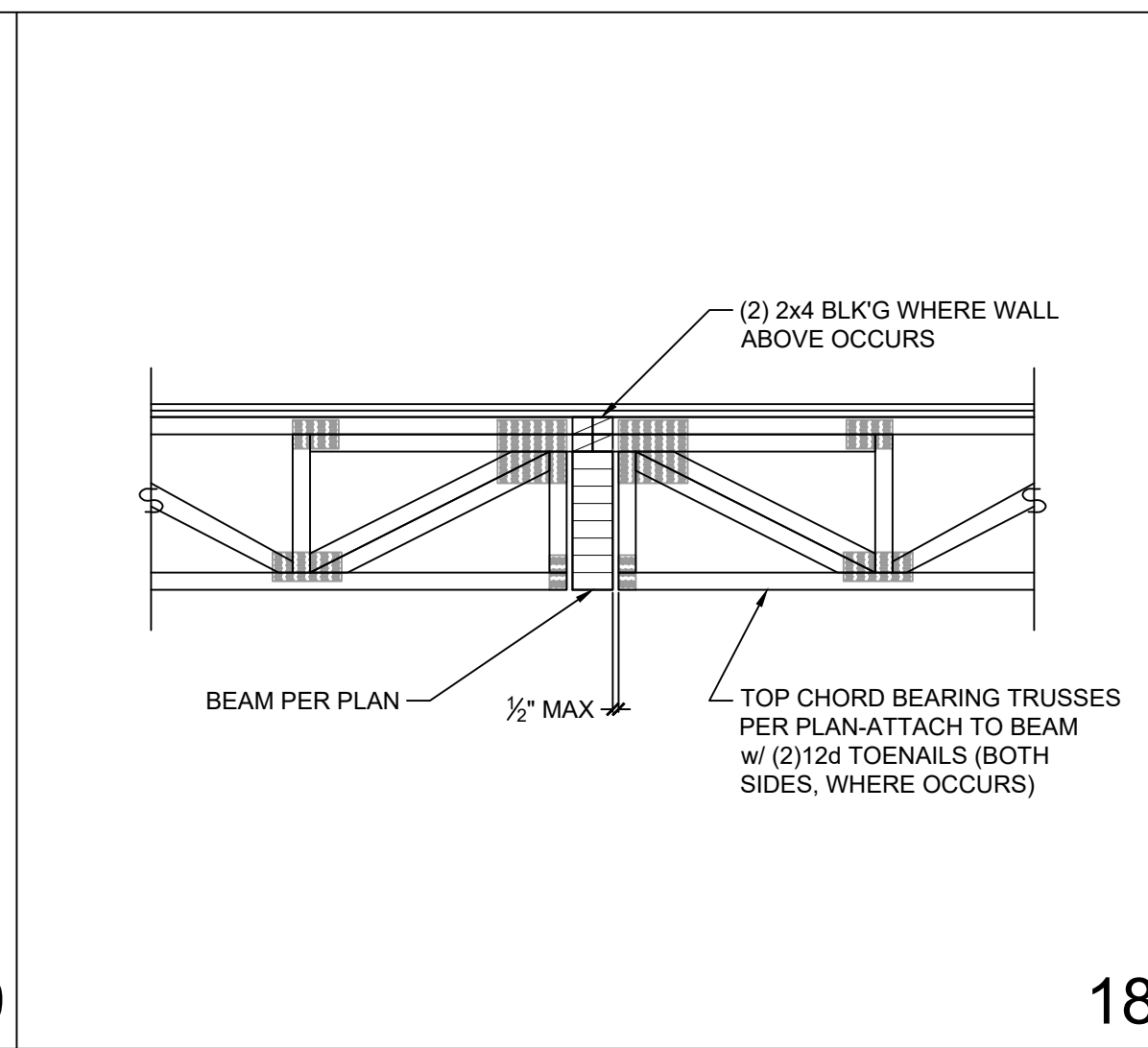

18

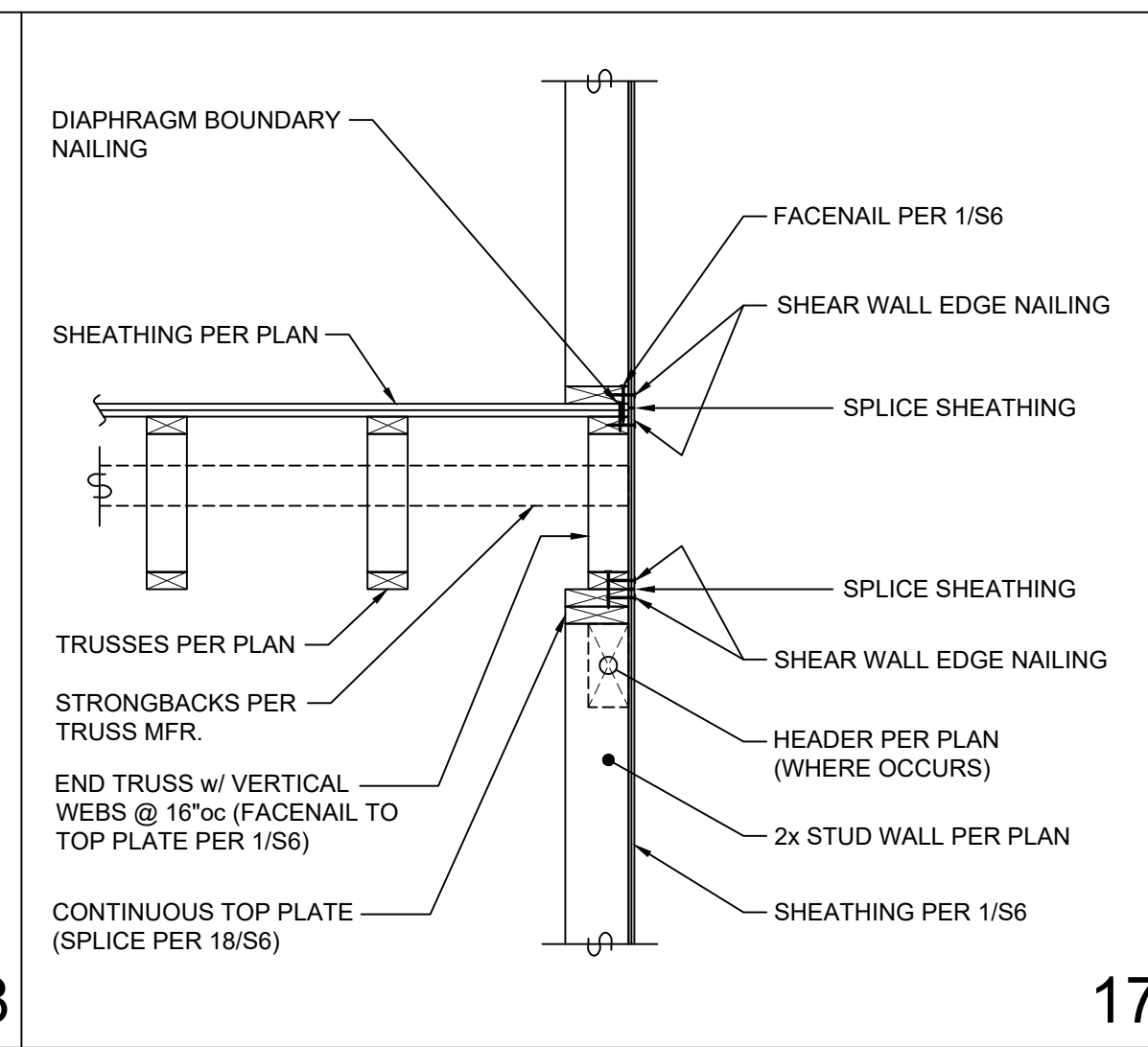

17

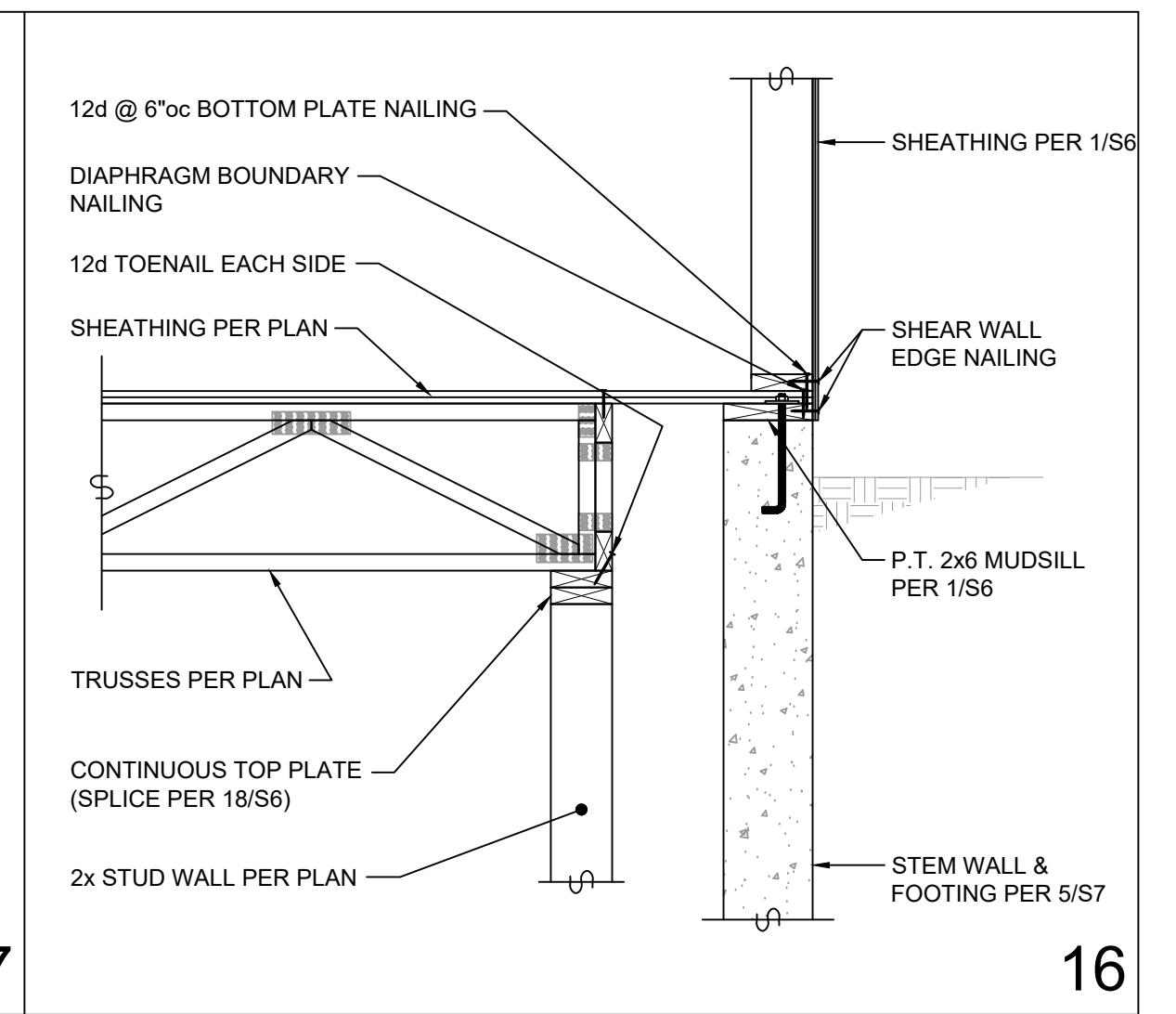

16

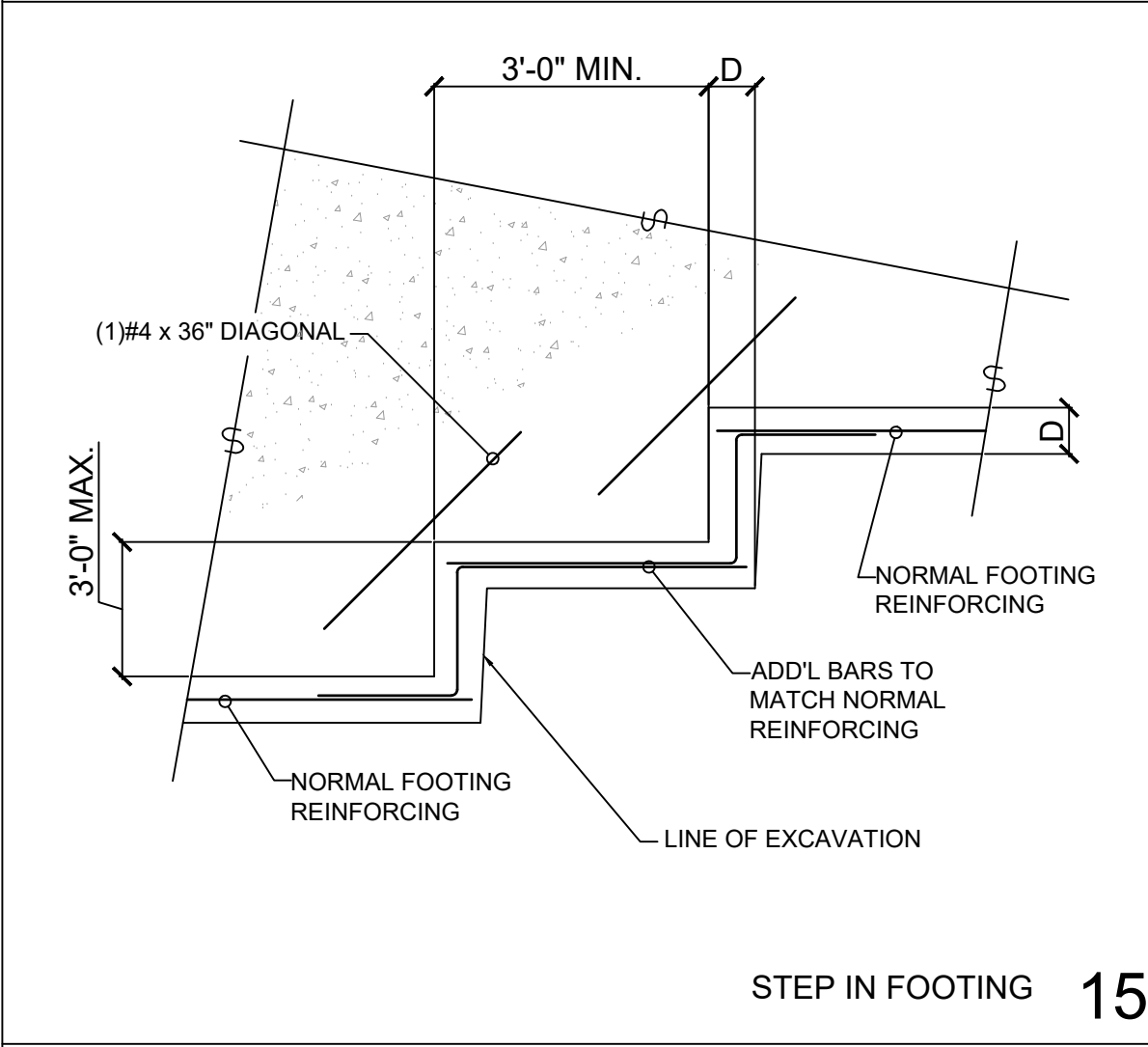

STEP IN FOOTING 15

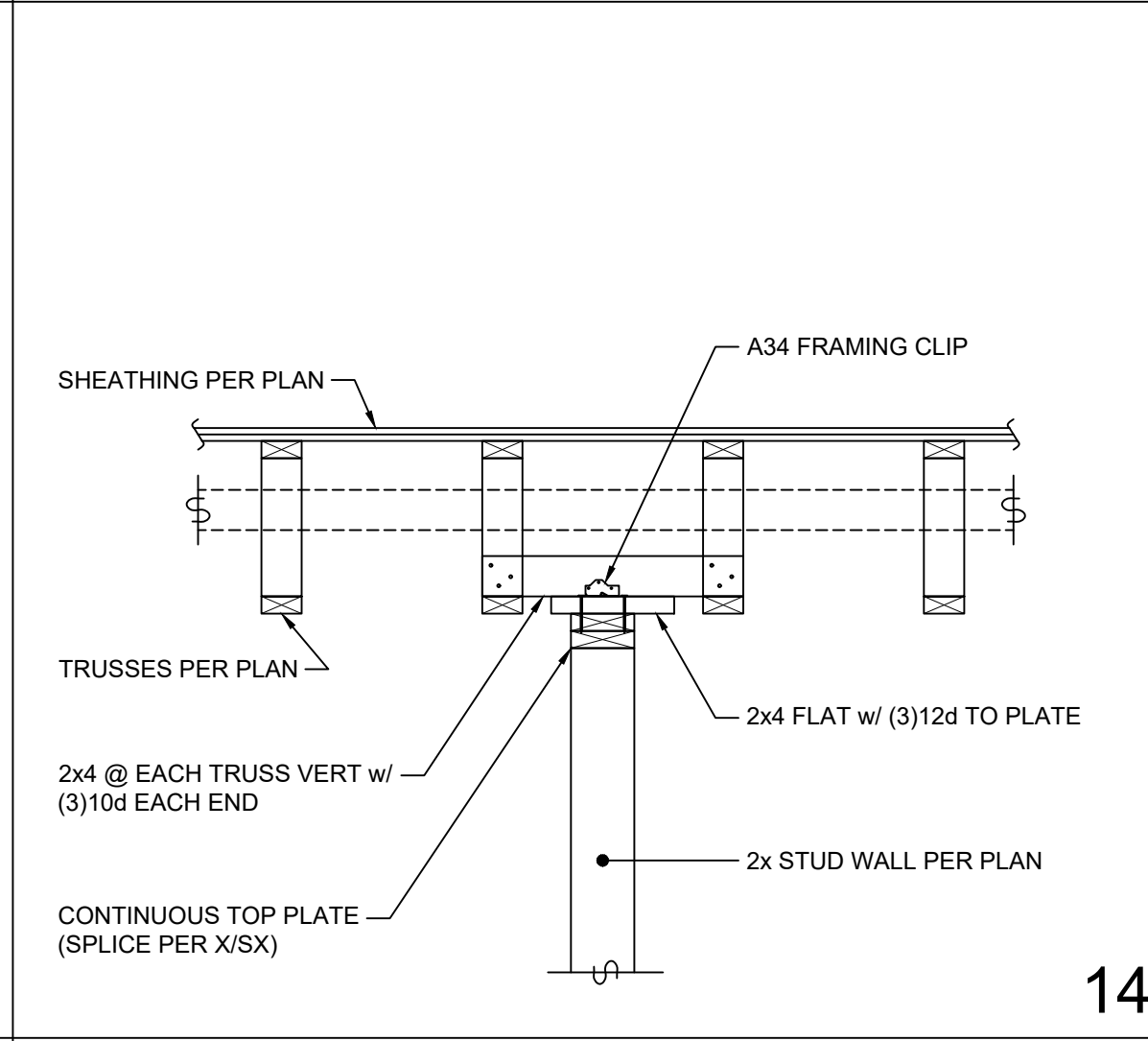

14

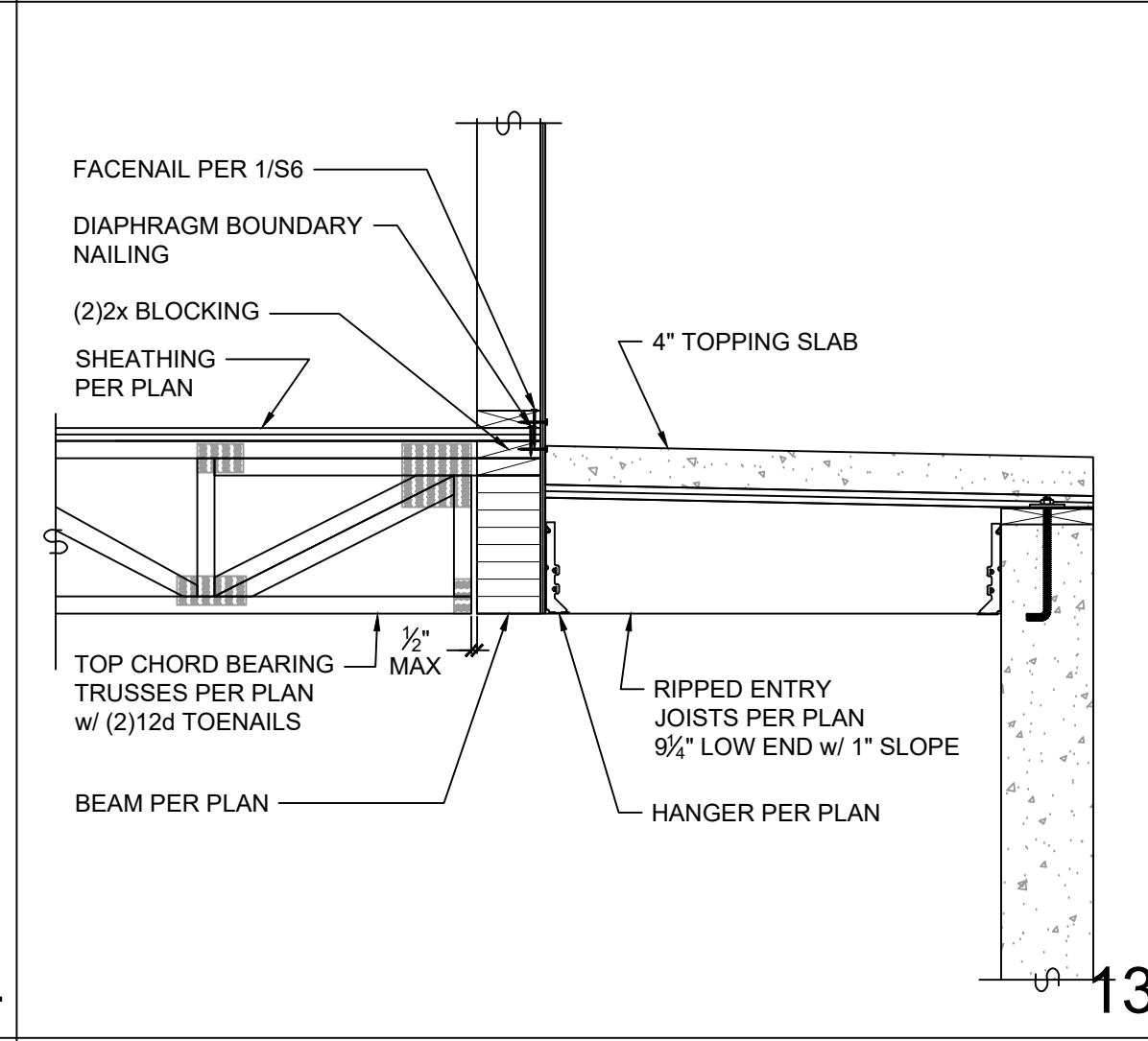

13

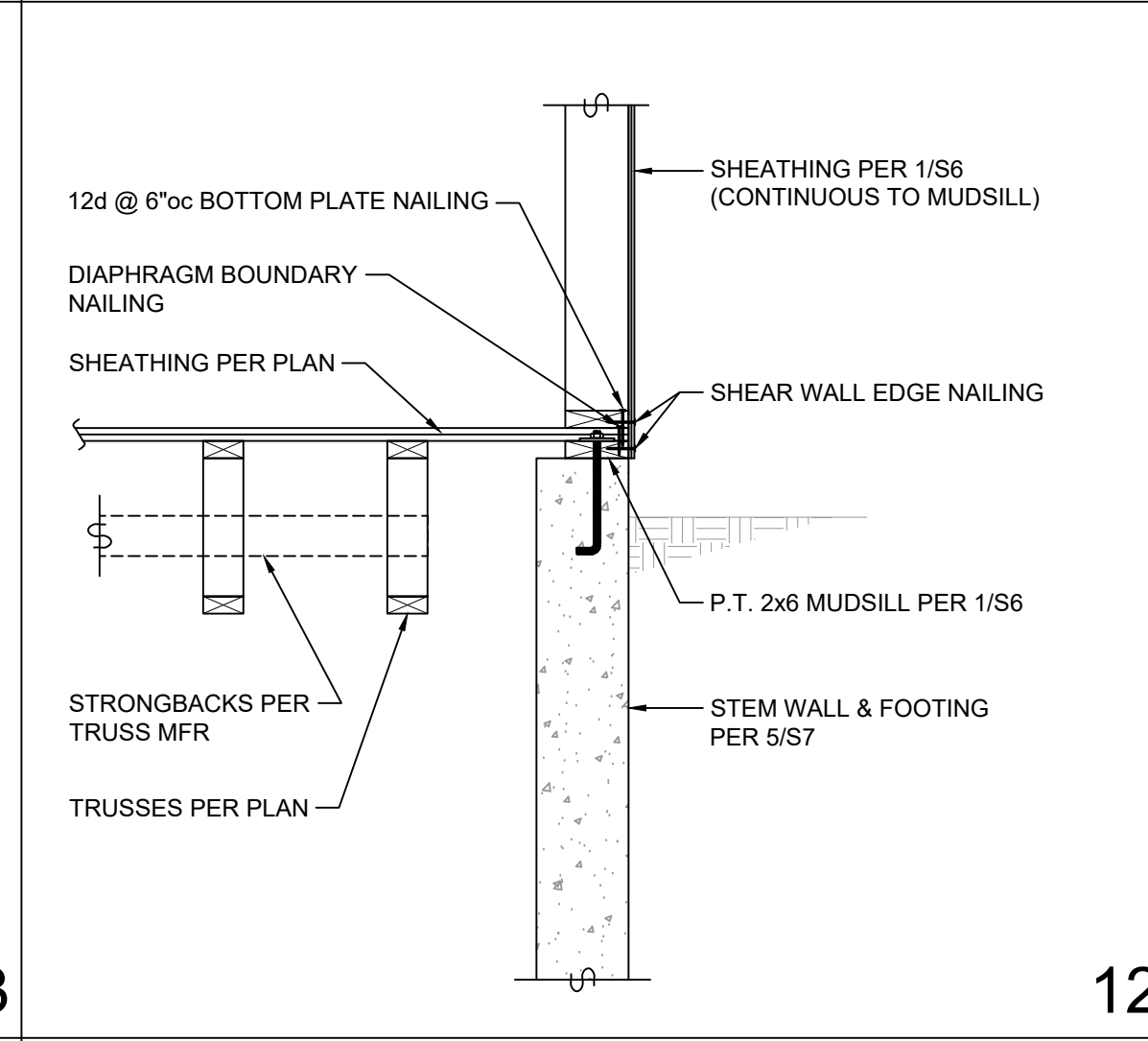

12

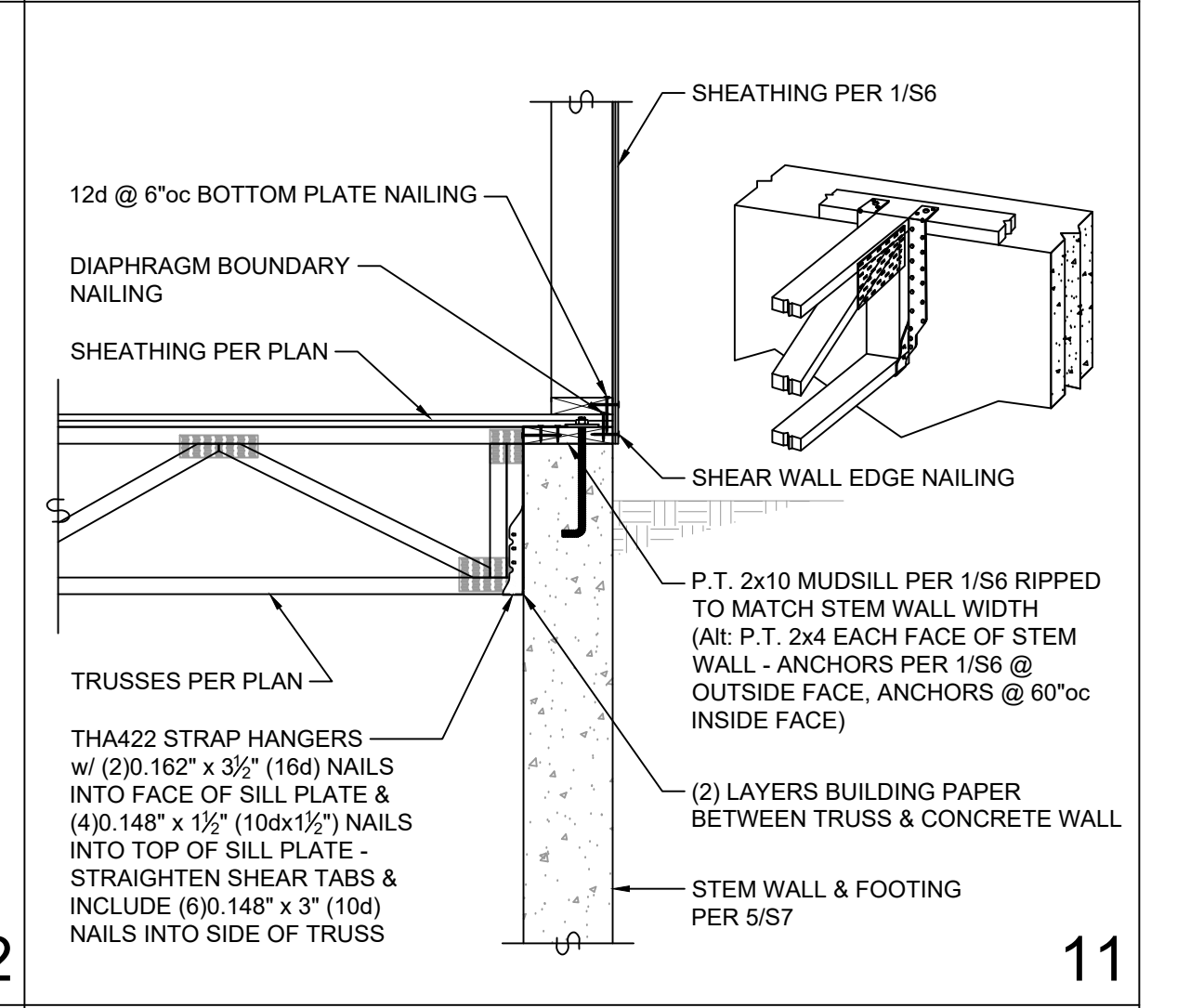

11

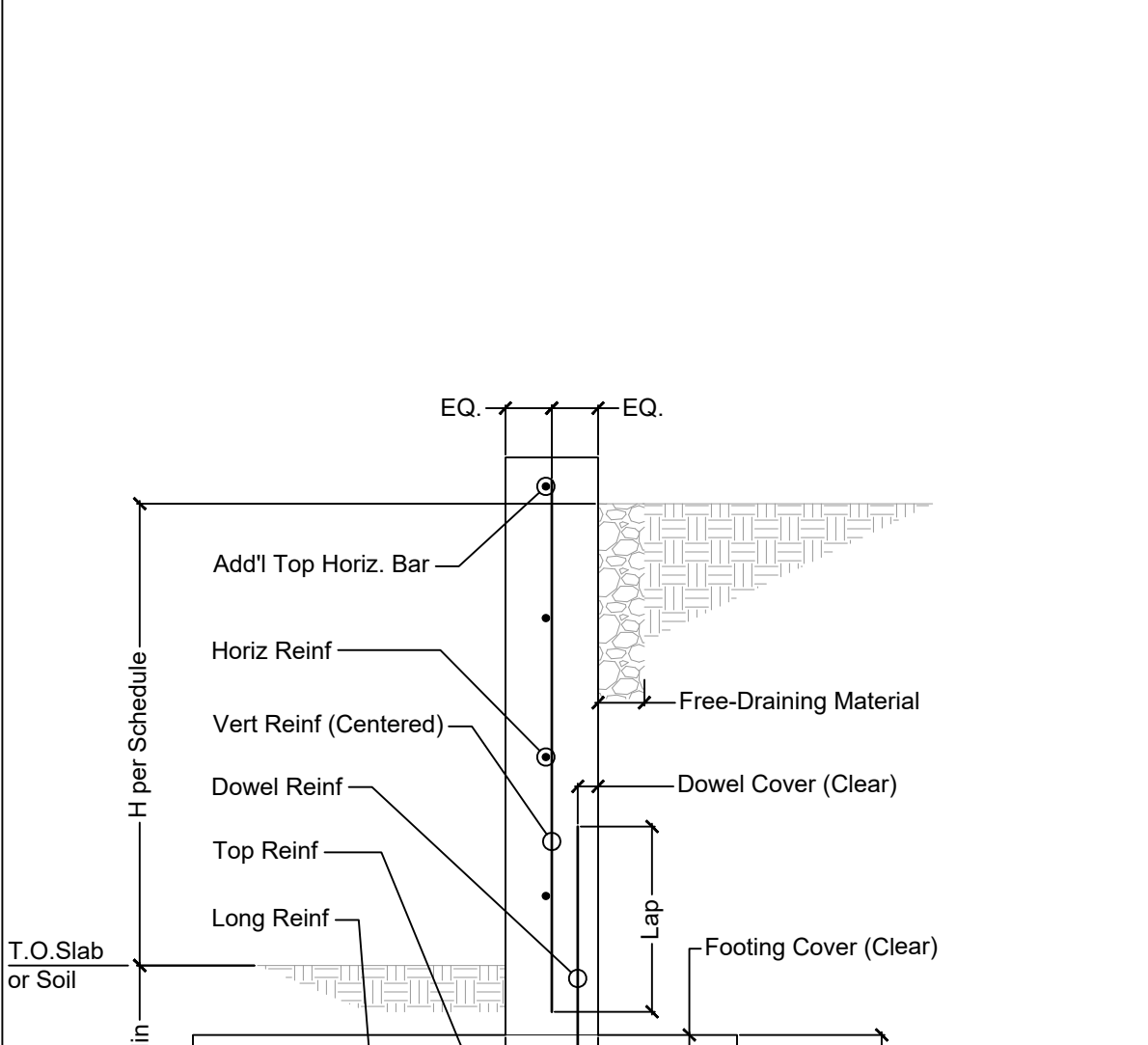

9

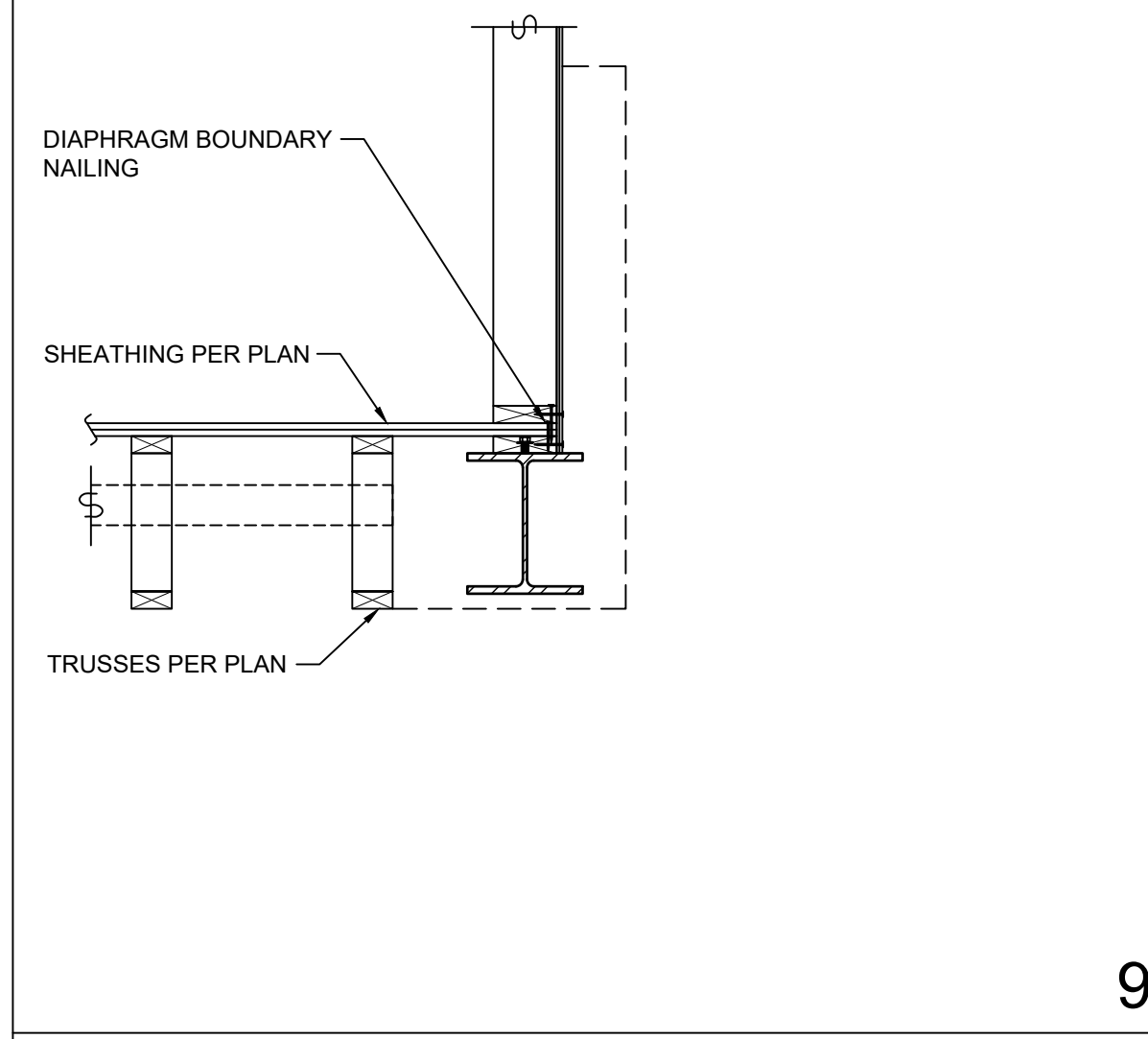

8

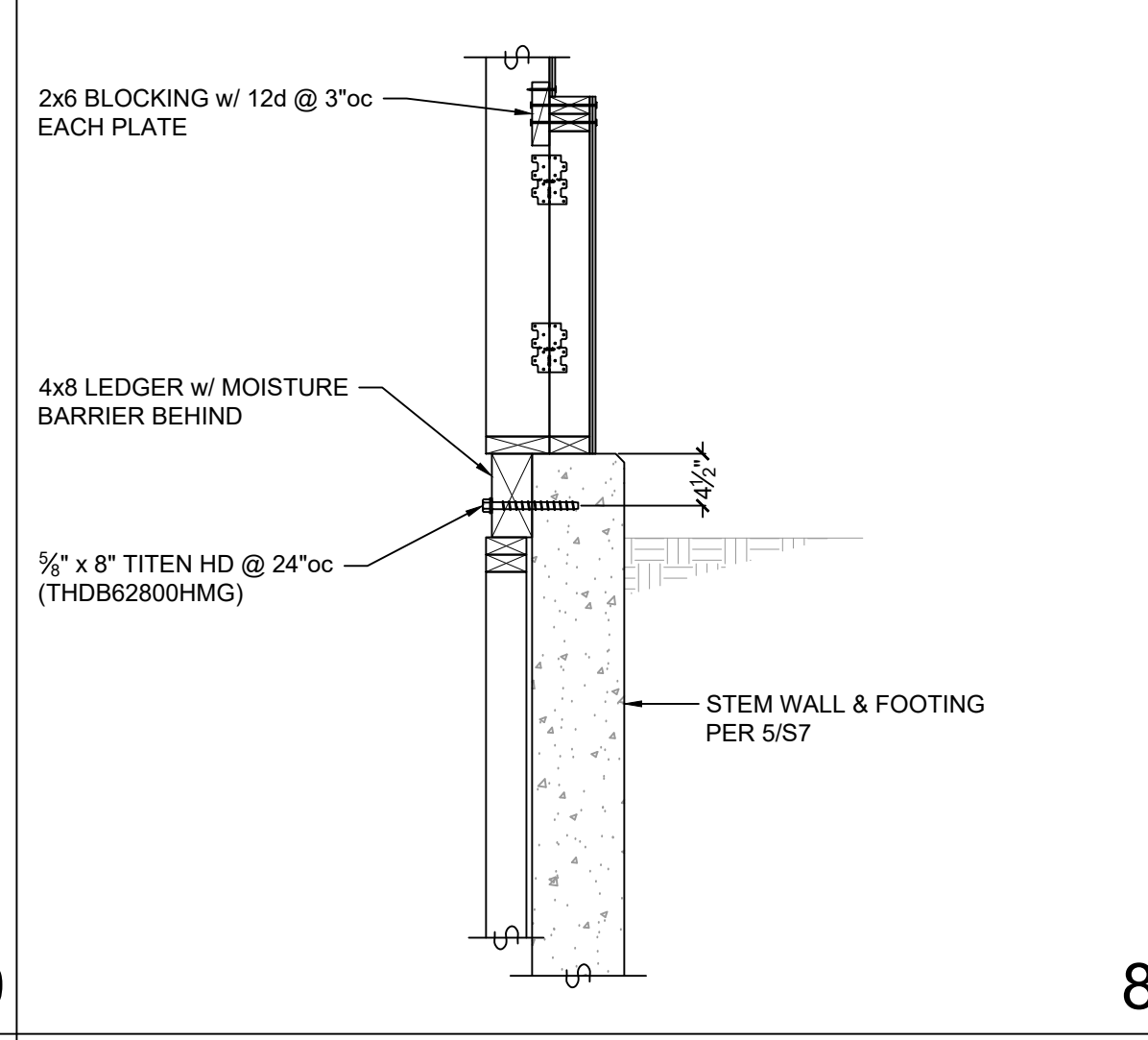

7

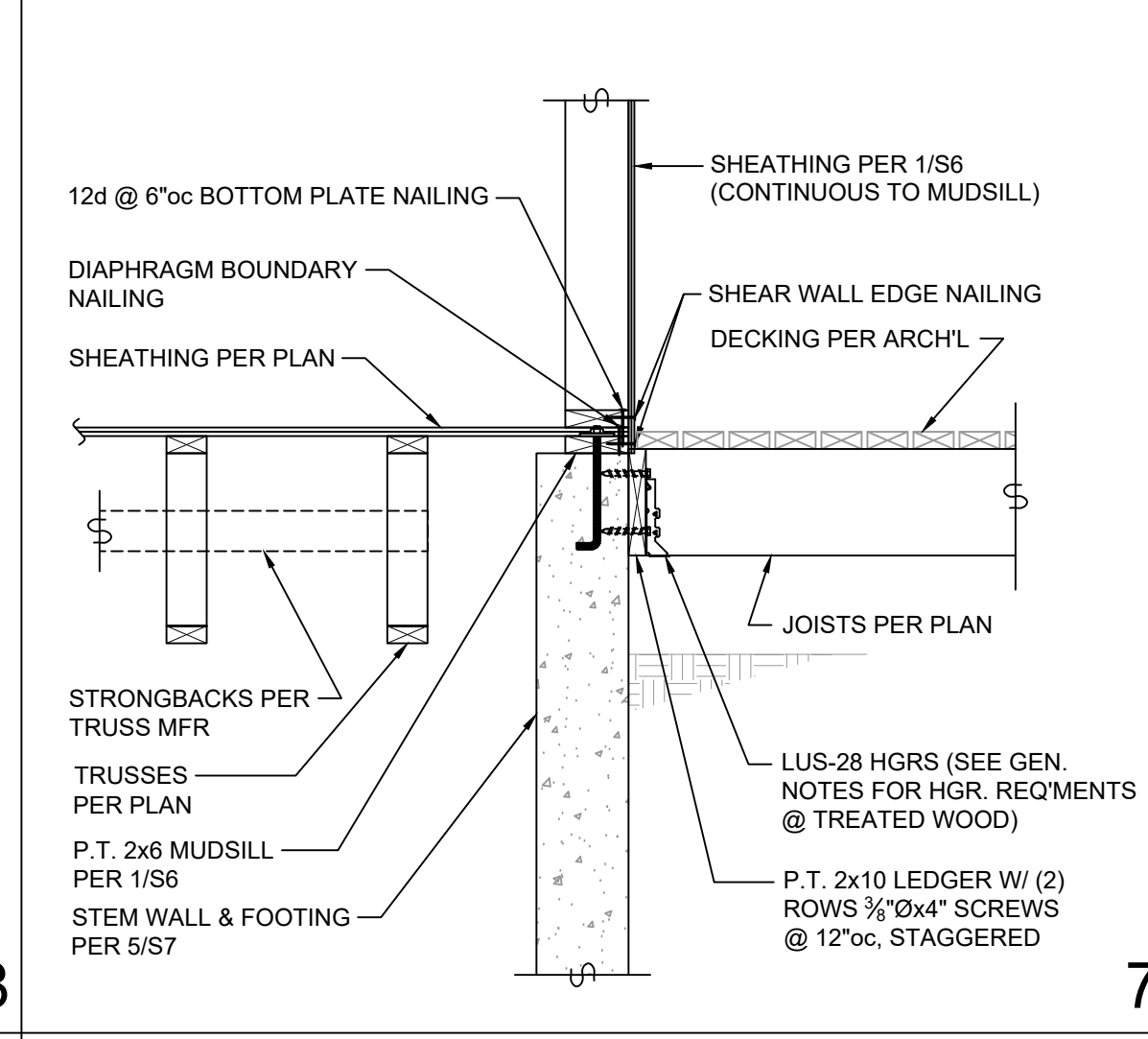

6

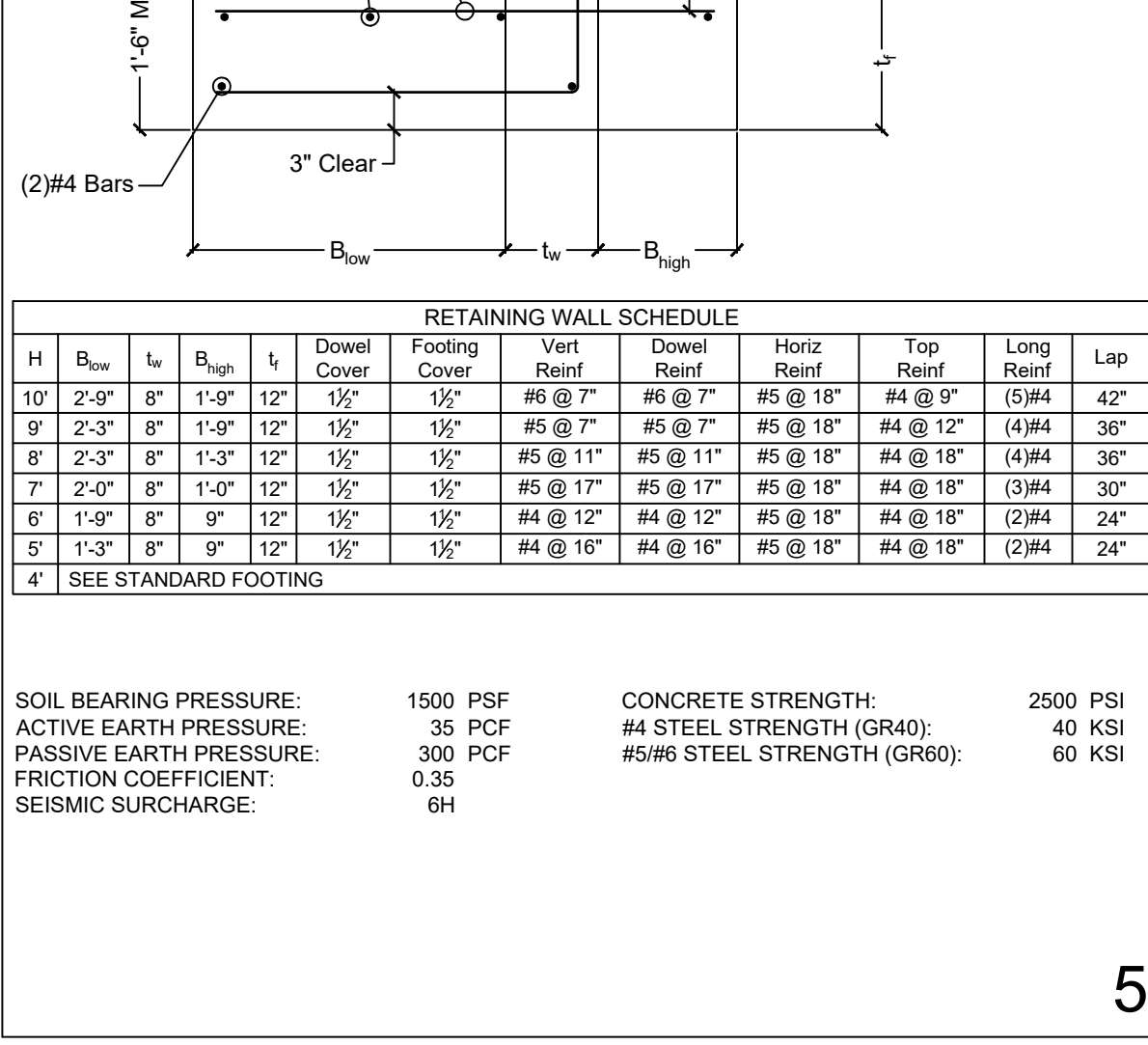

5

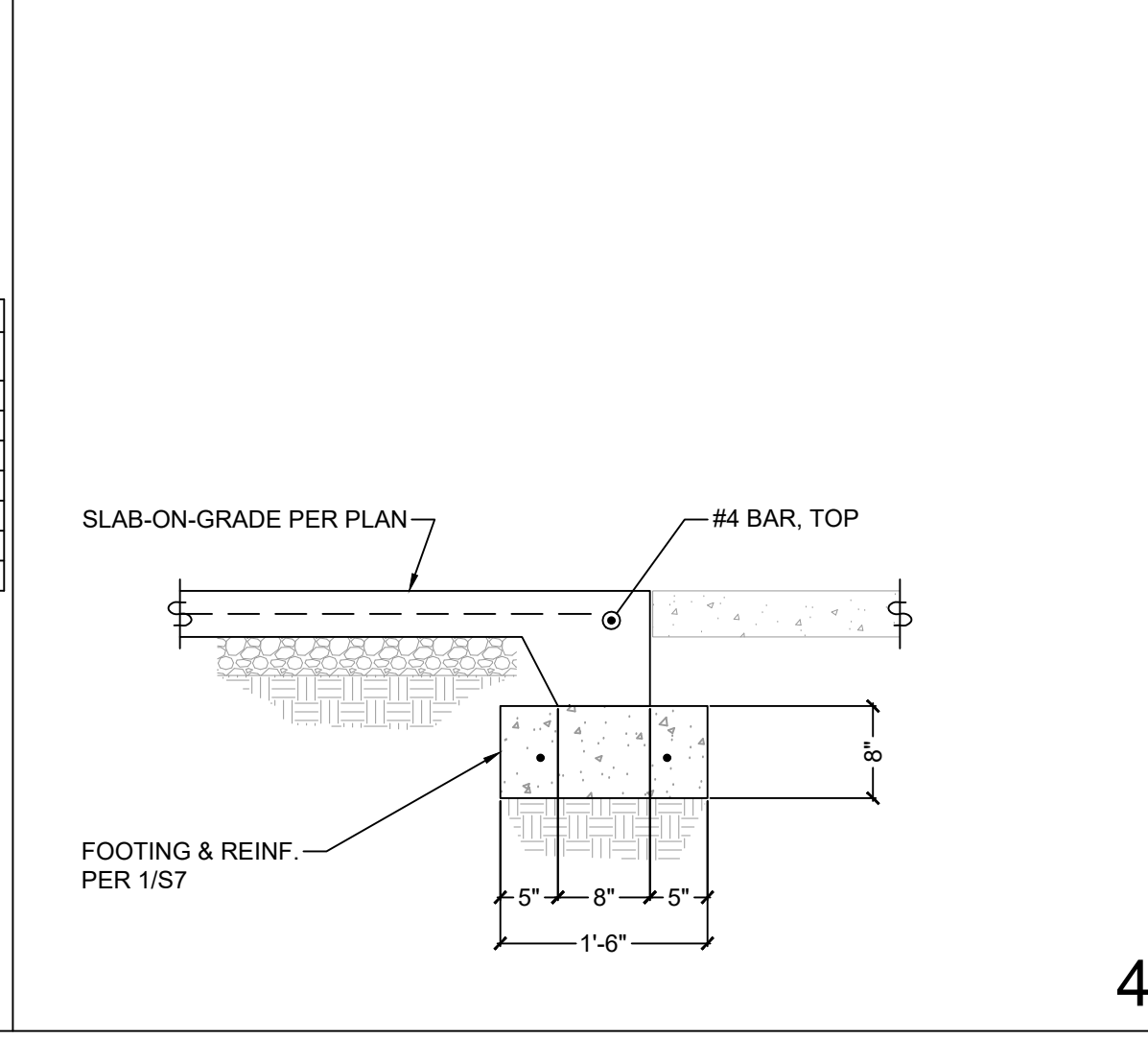

4

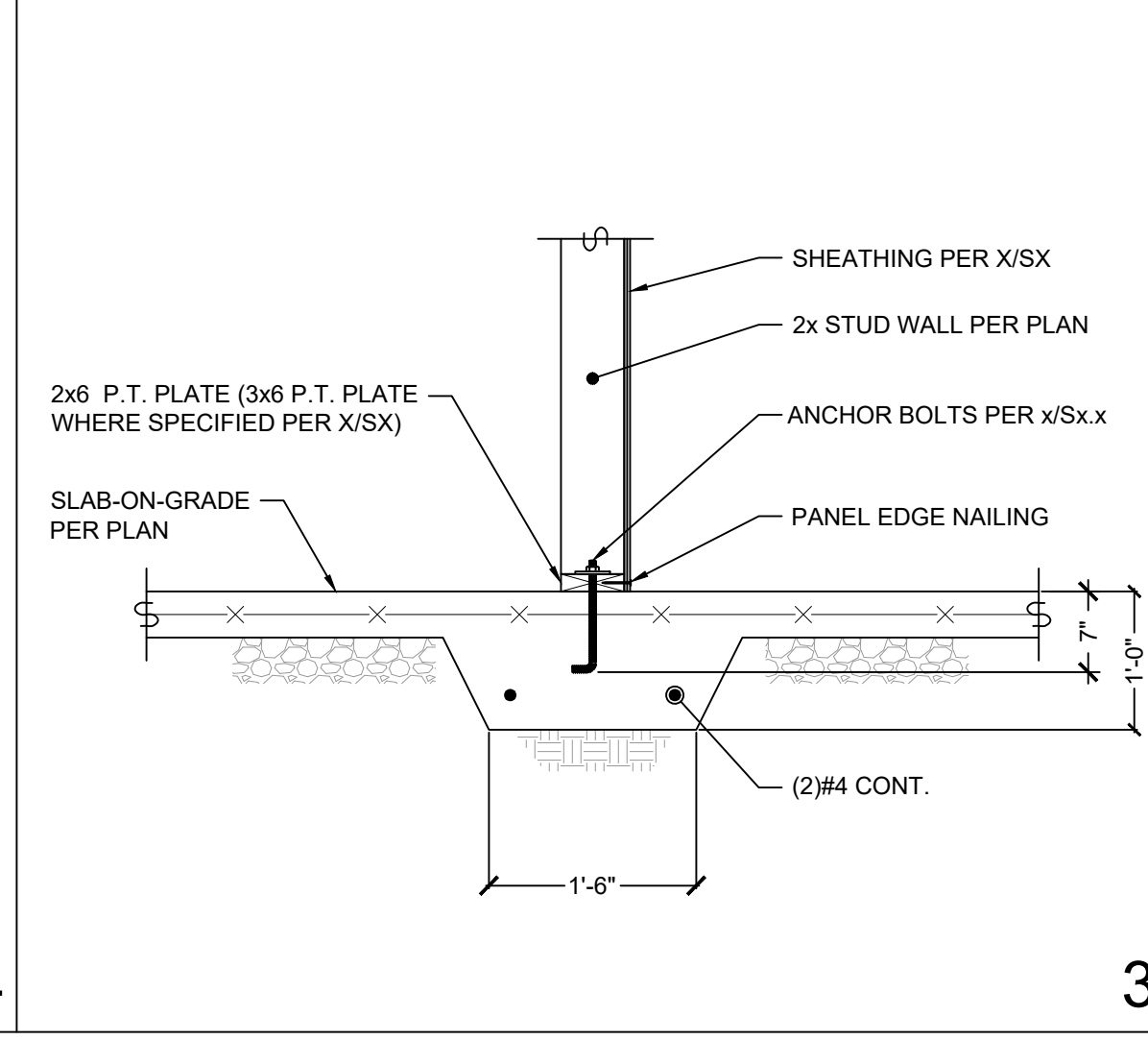

3

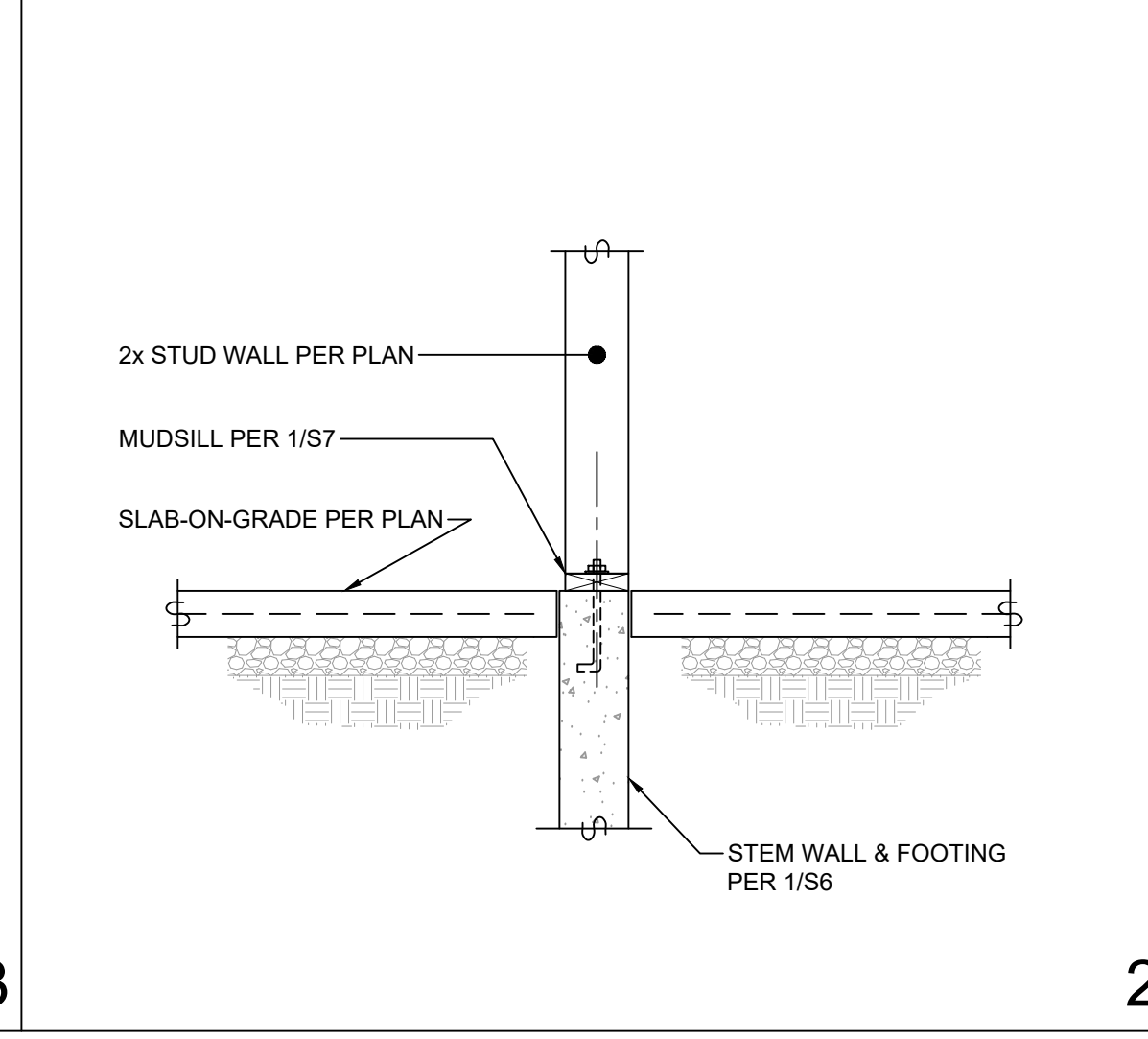

2

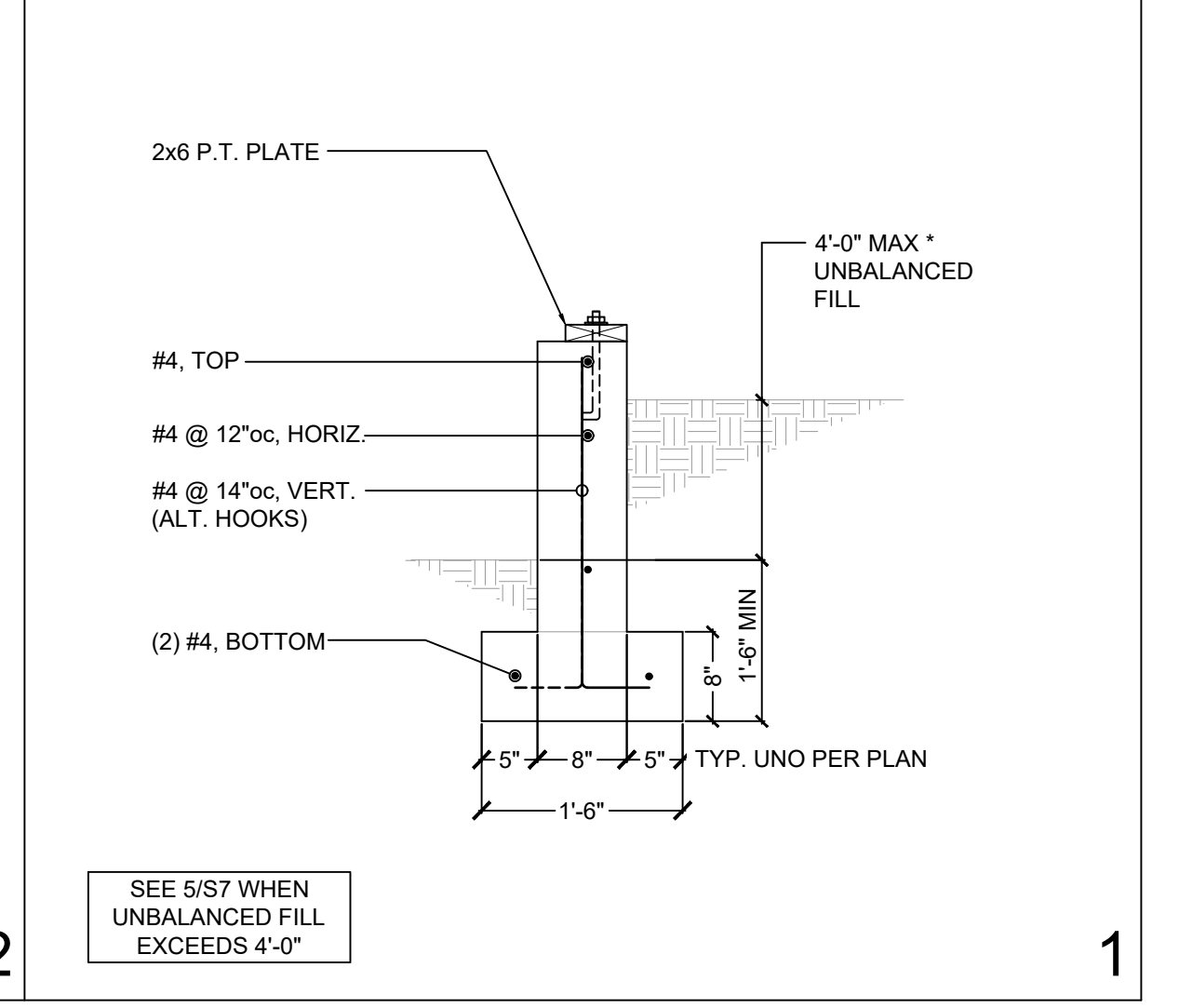

1

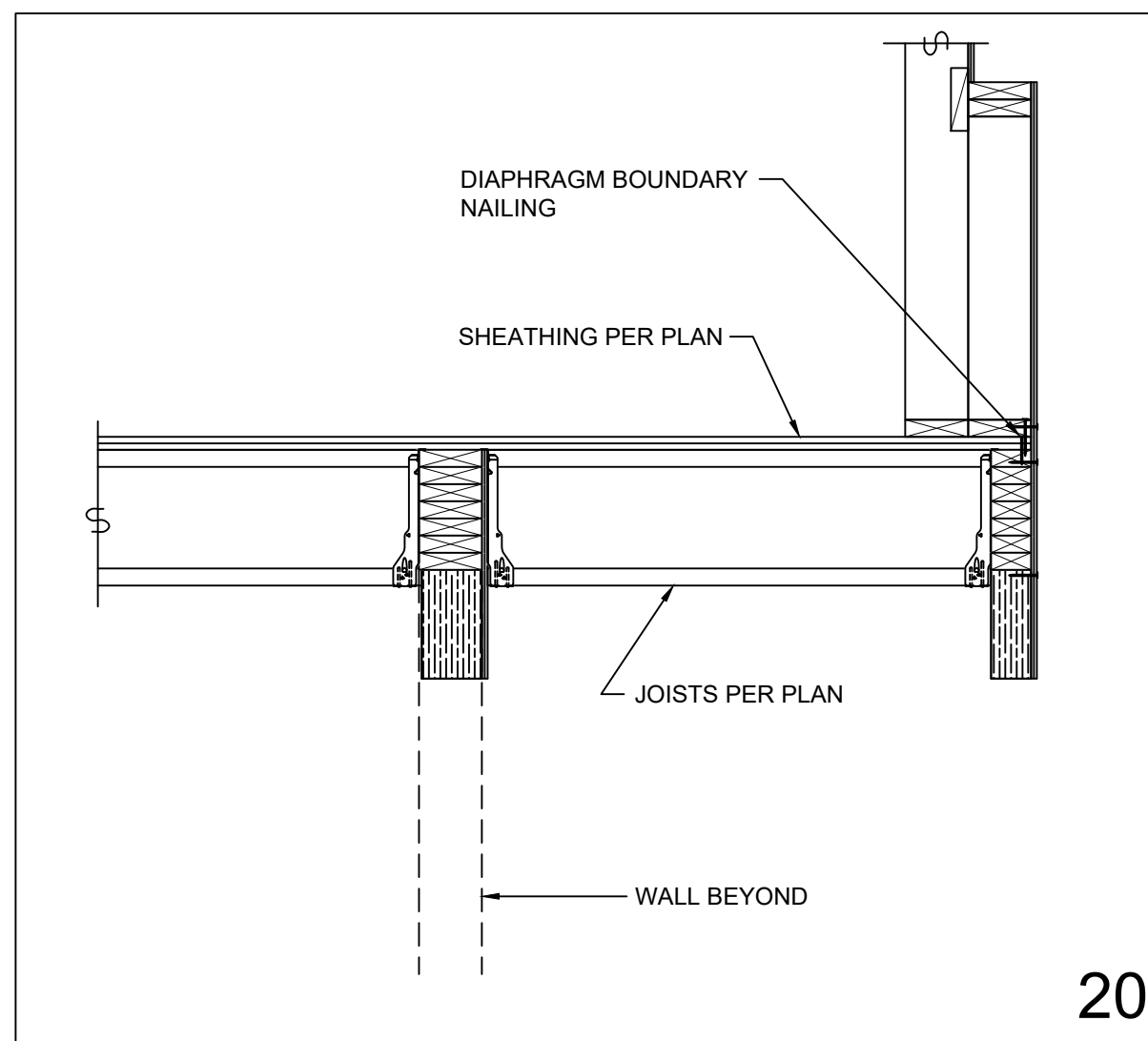

20

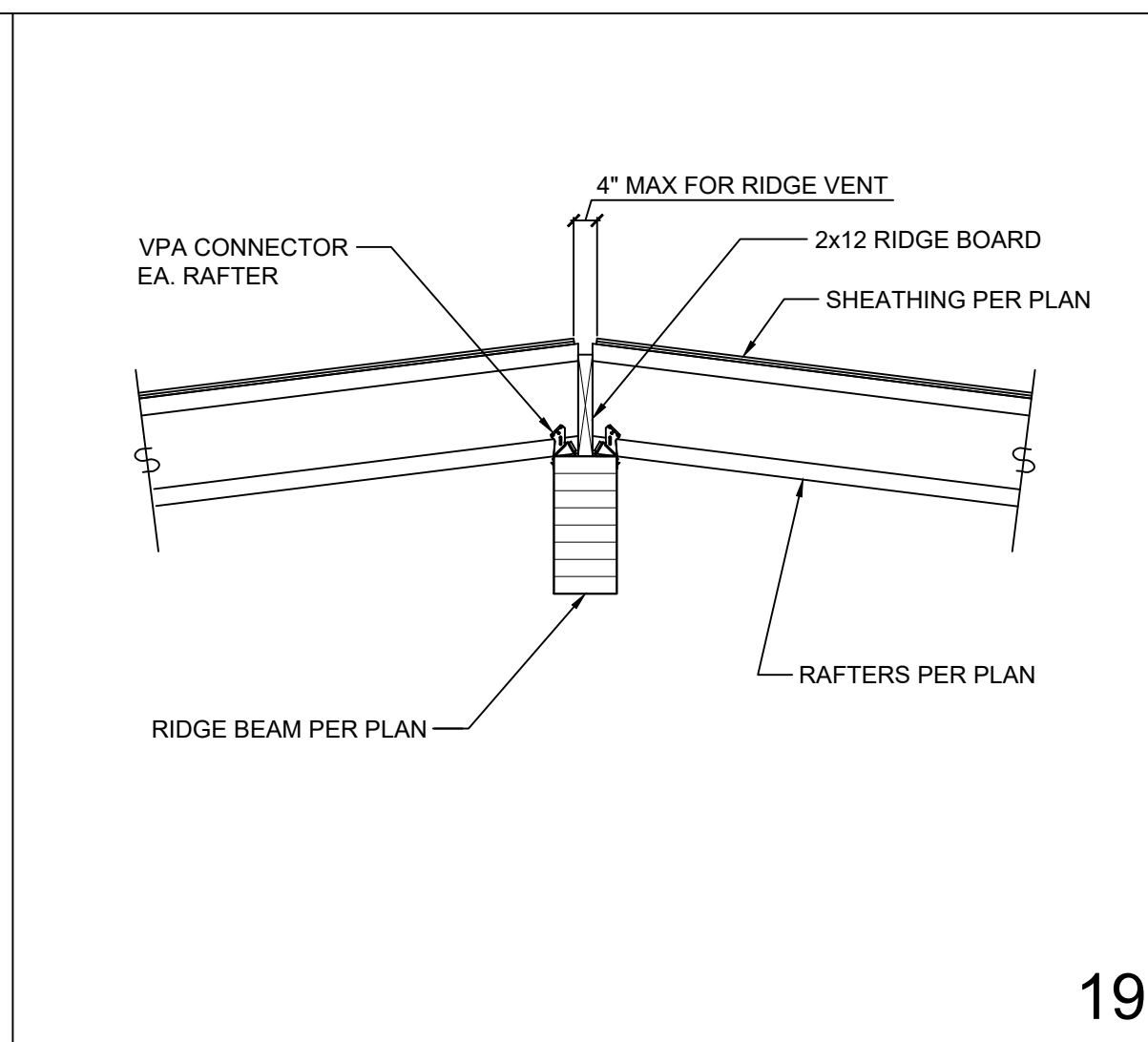

19

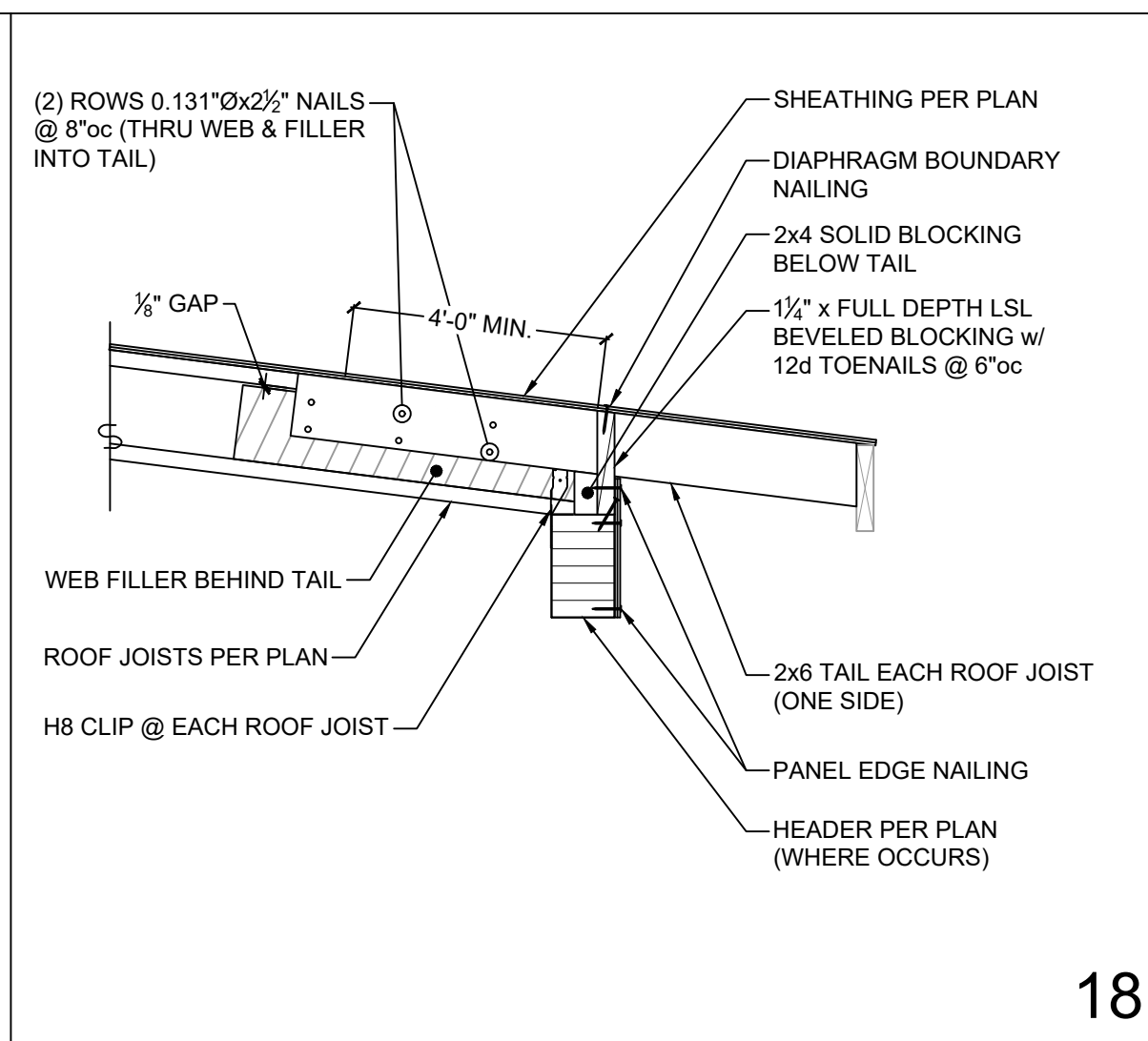

18

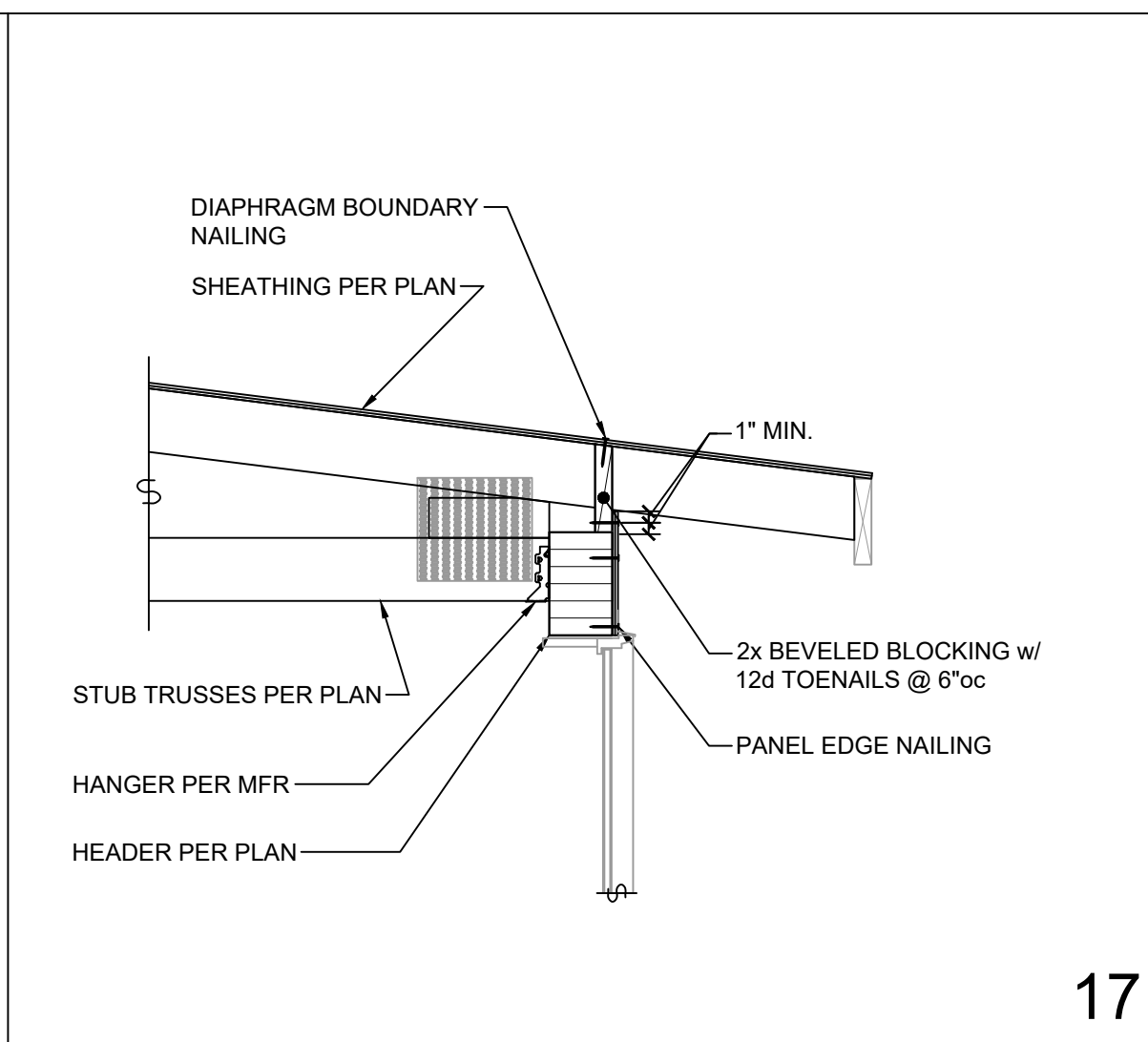

17

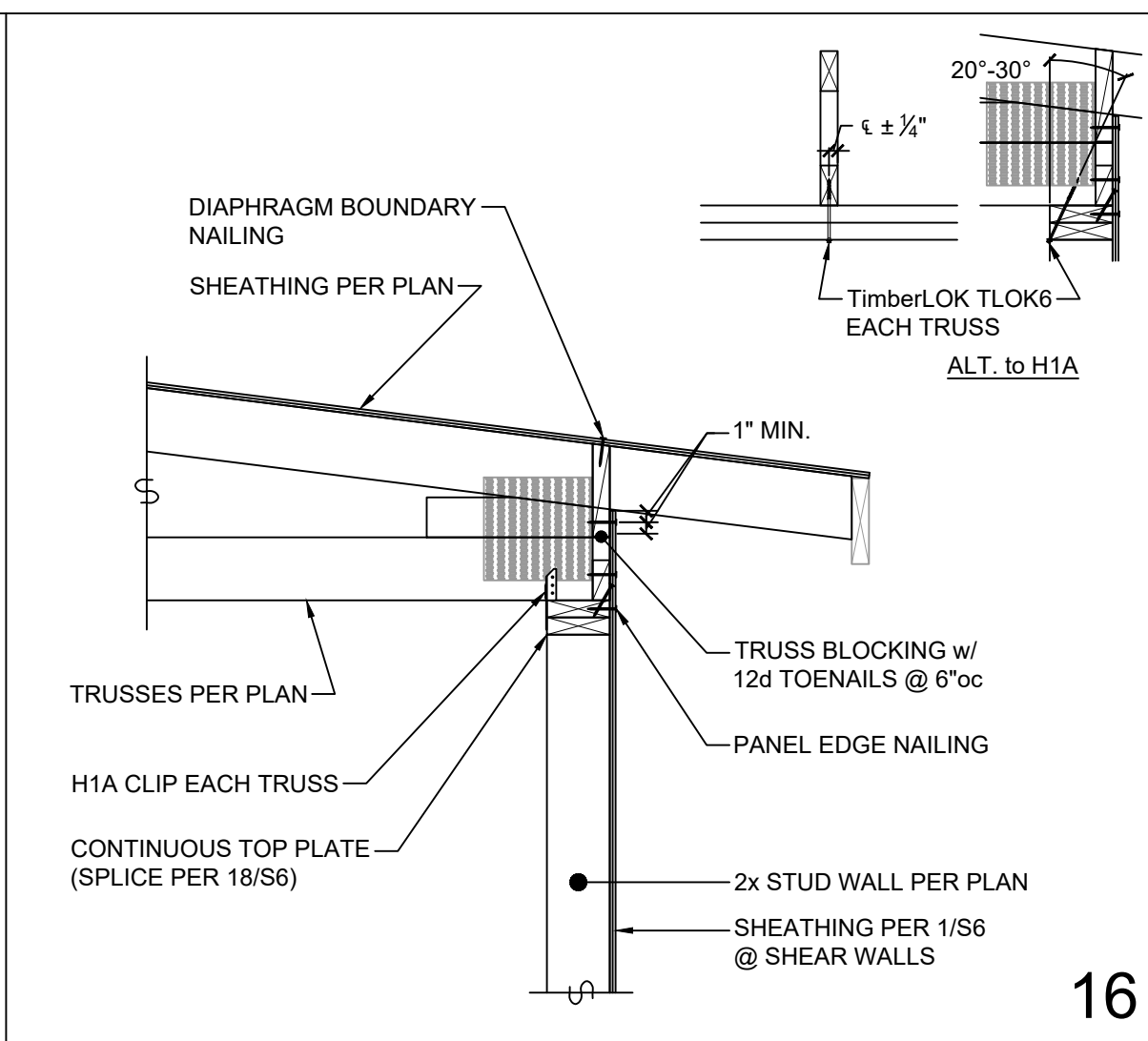

16

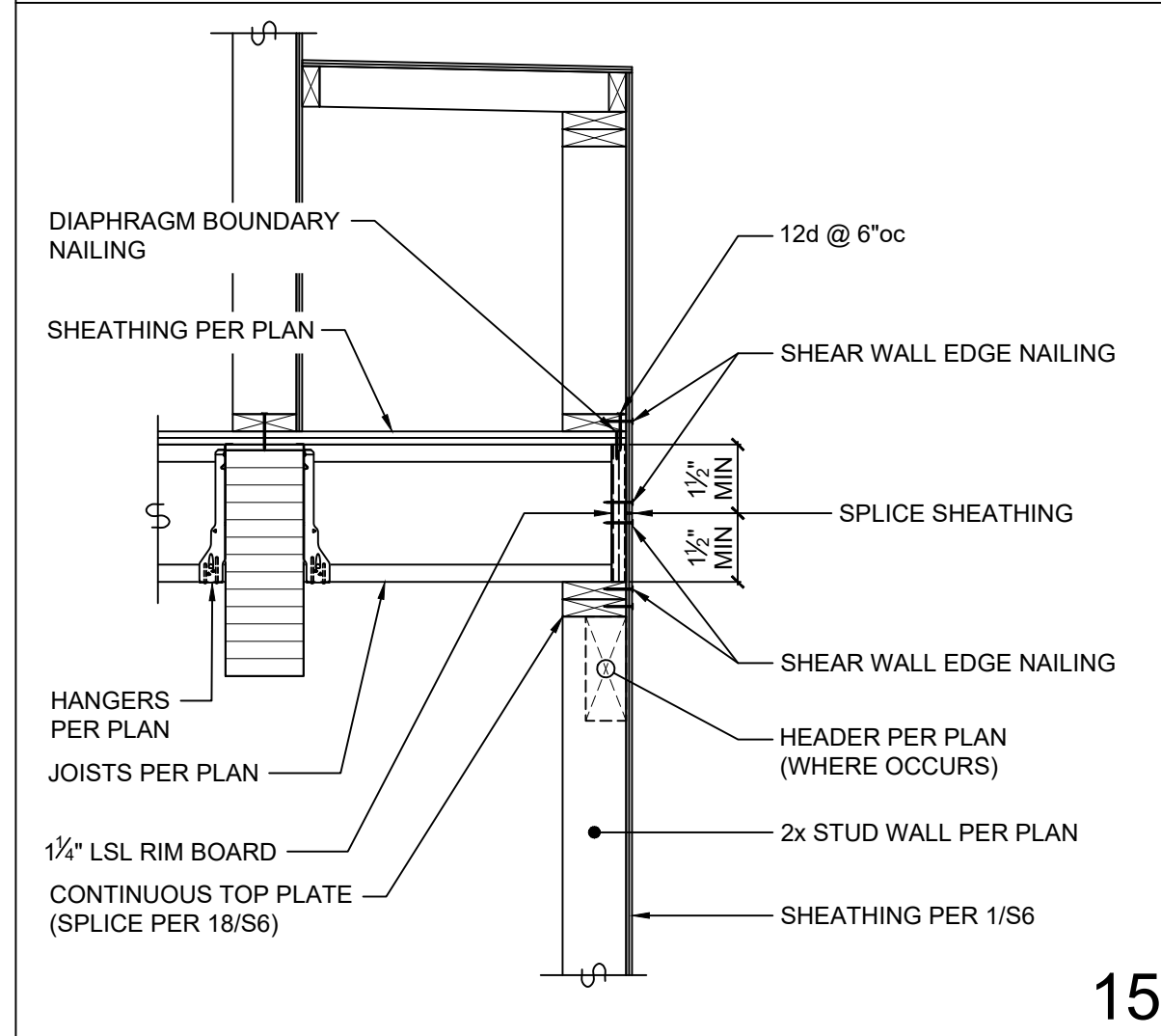

15

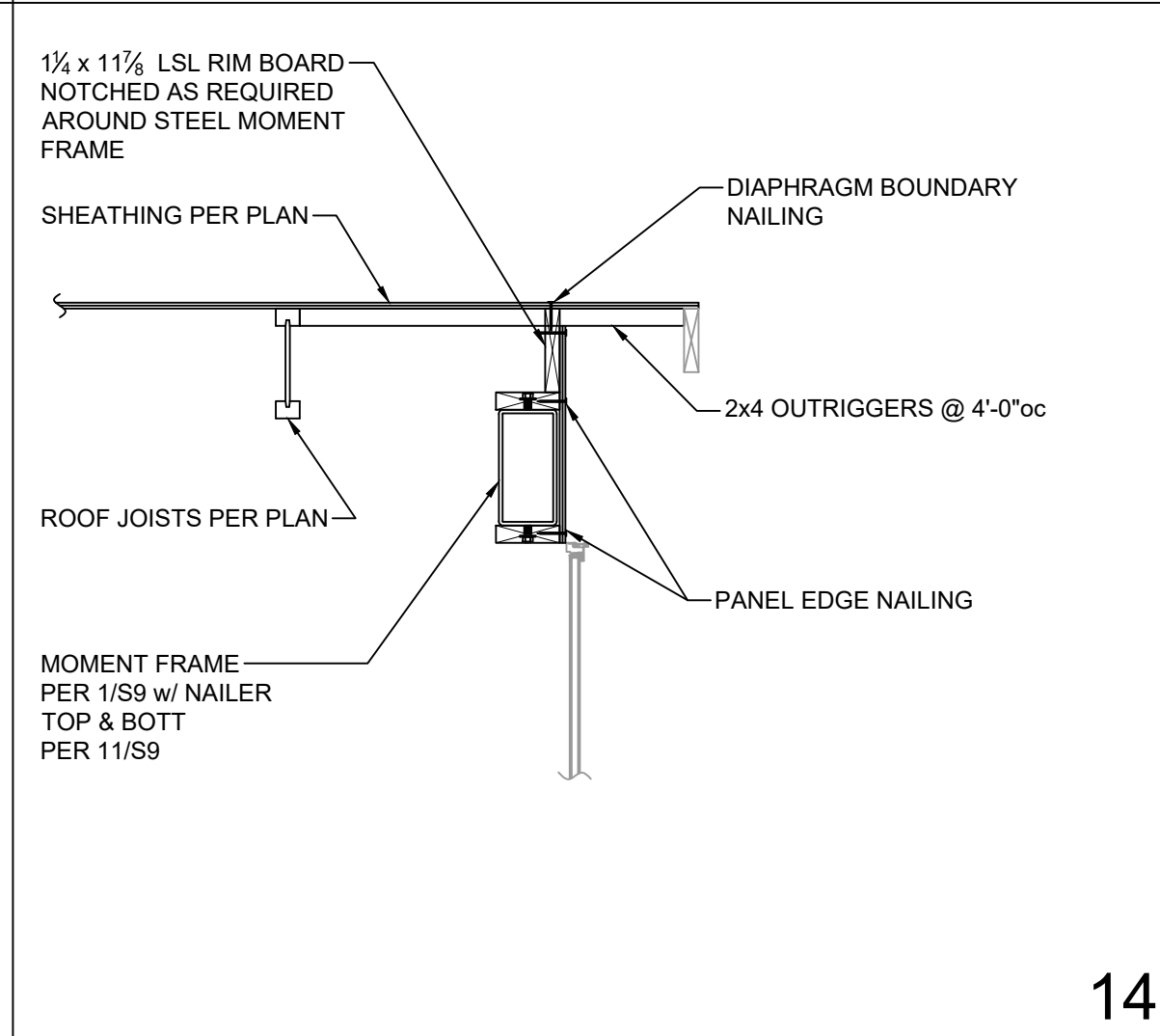

14

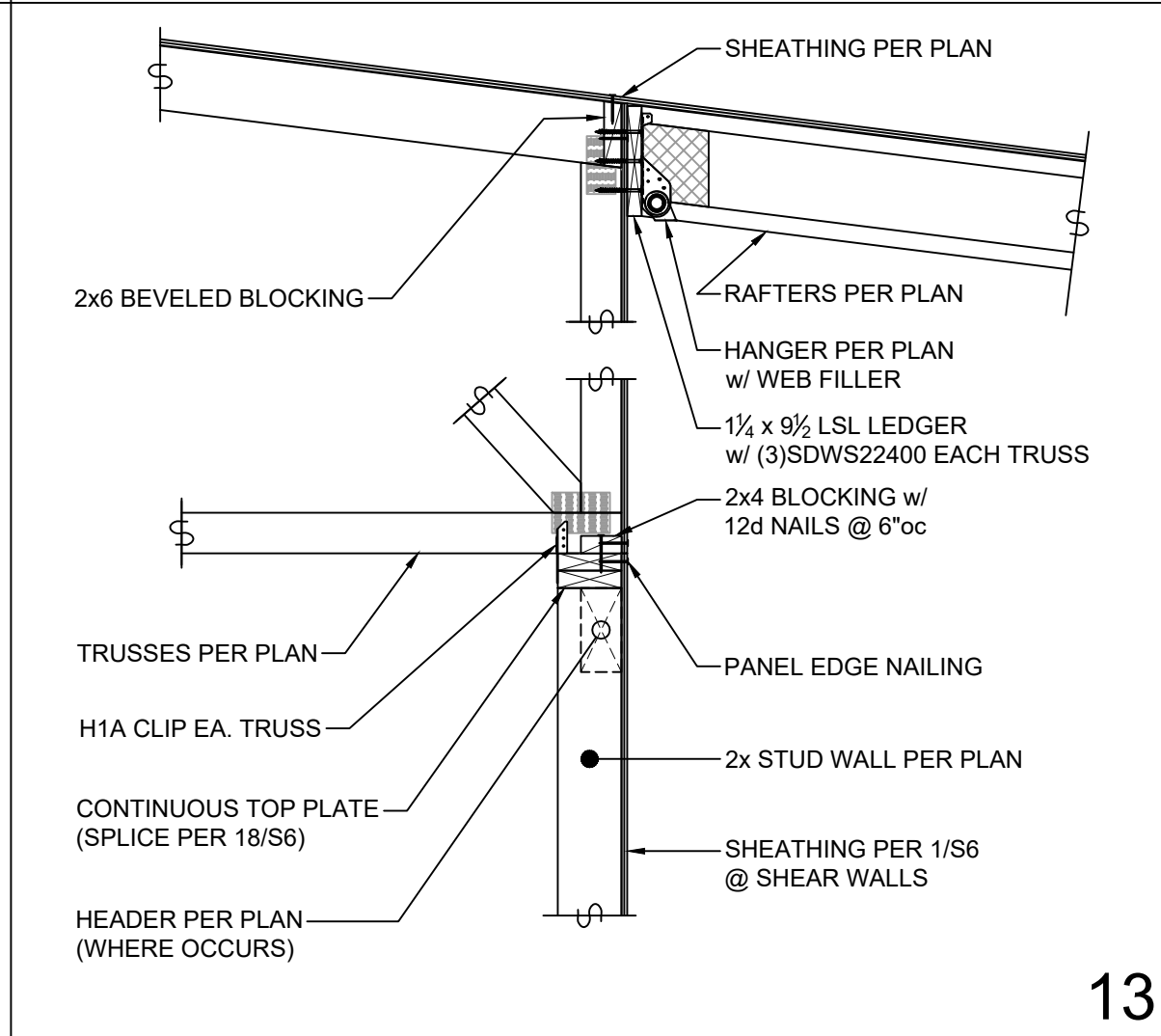

13

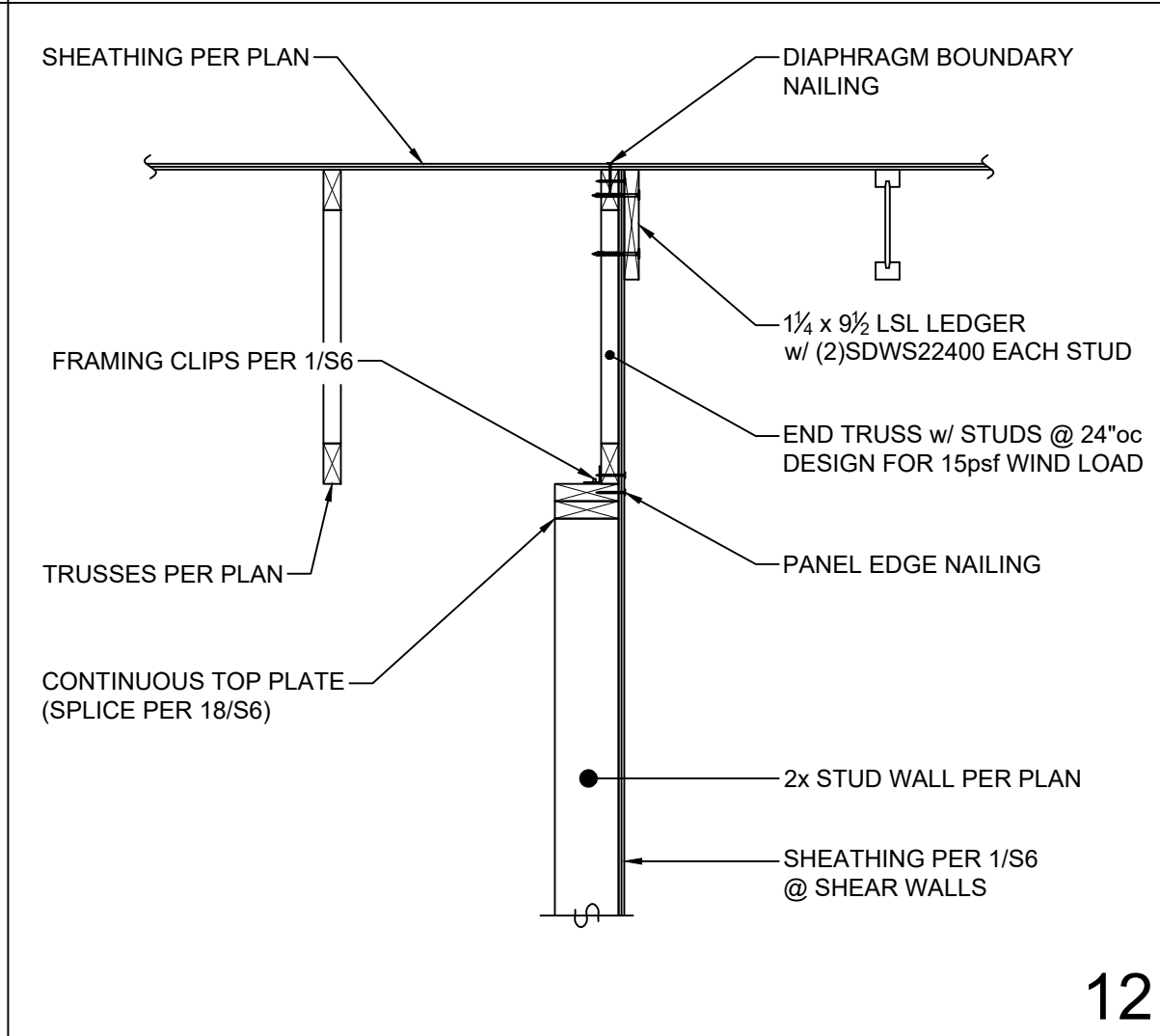

12

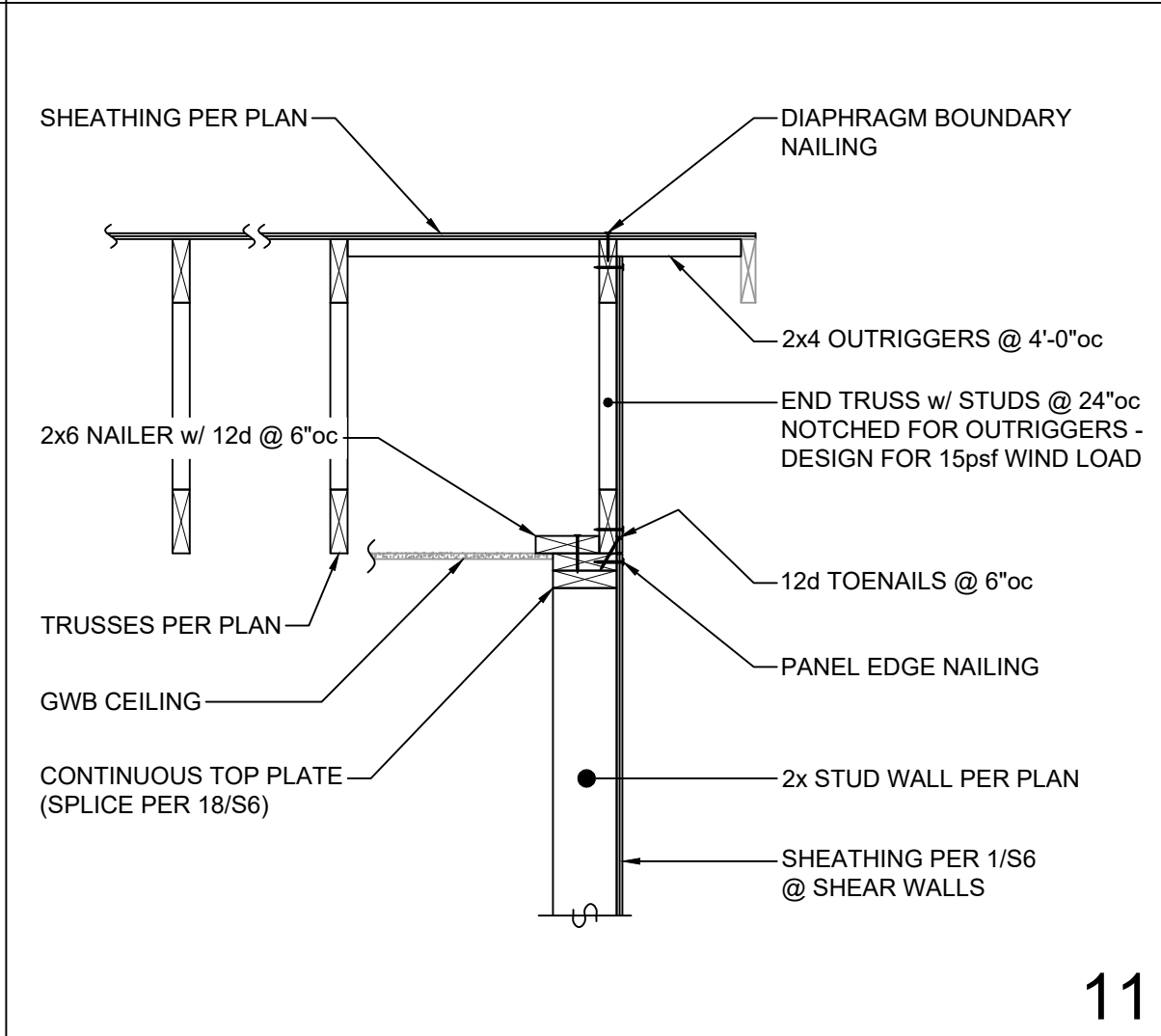

11

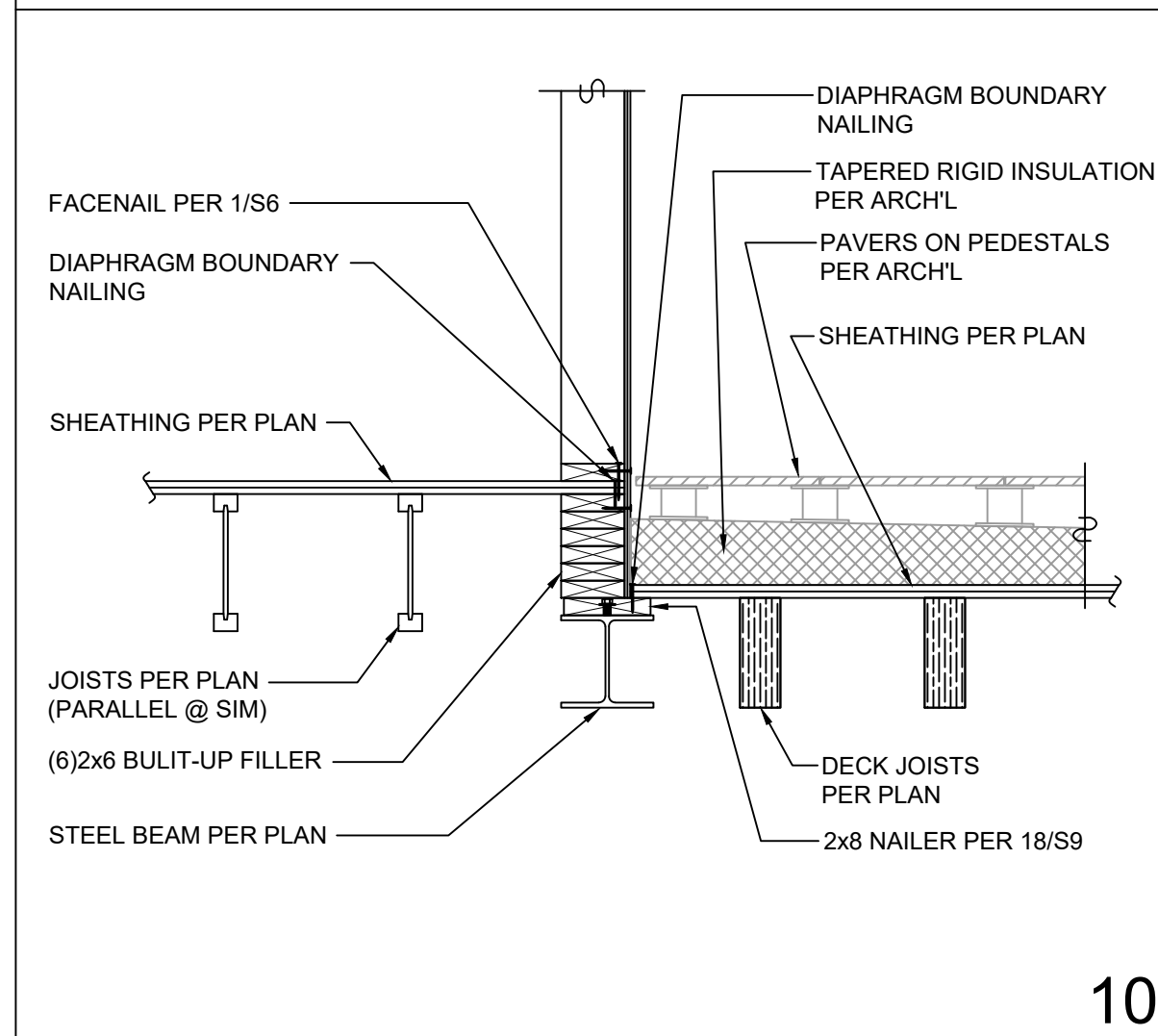

10

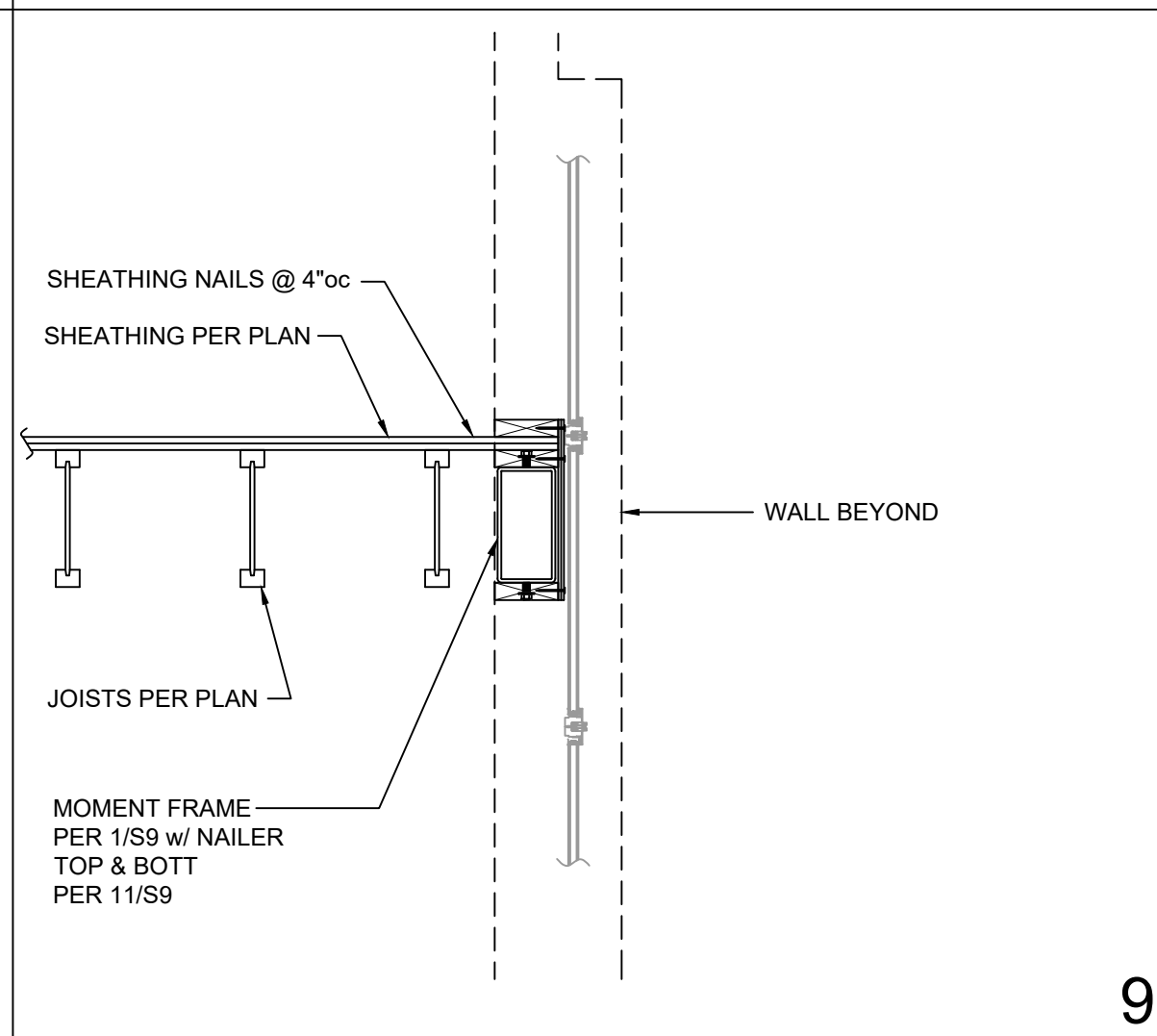

9

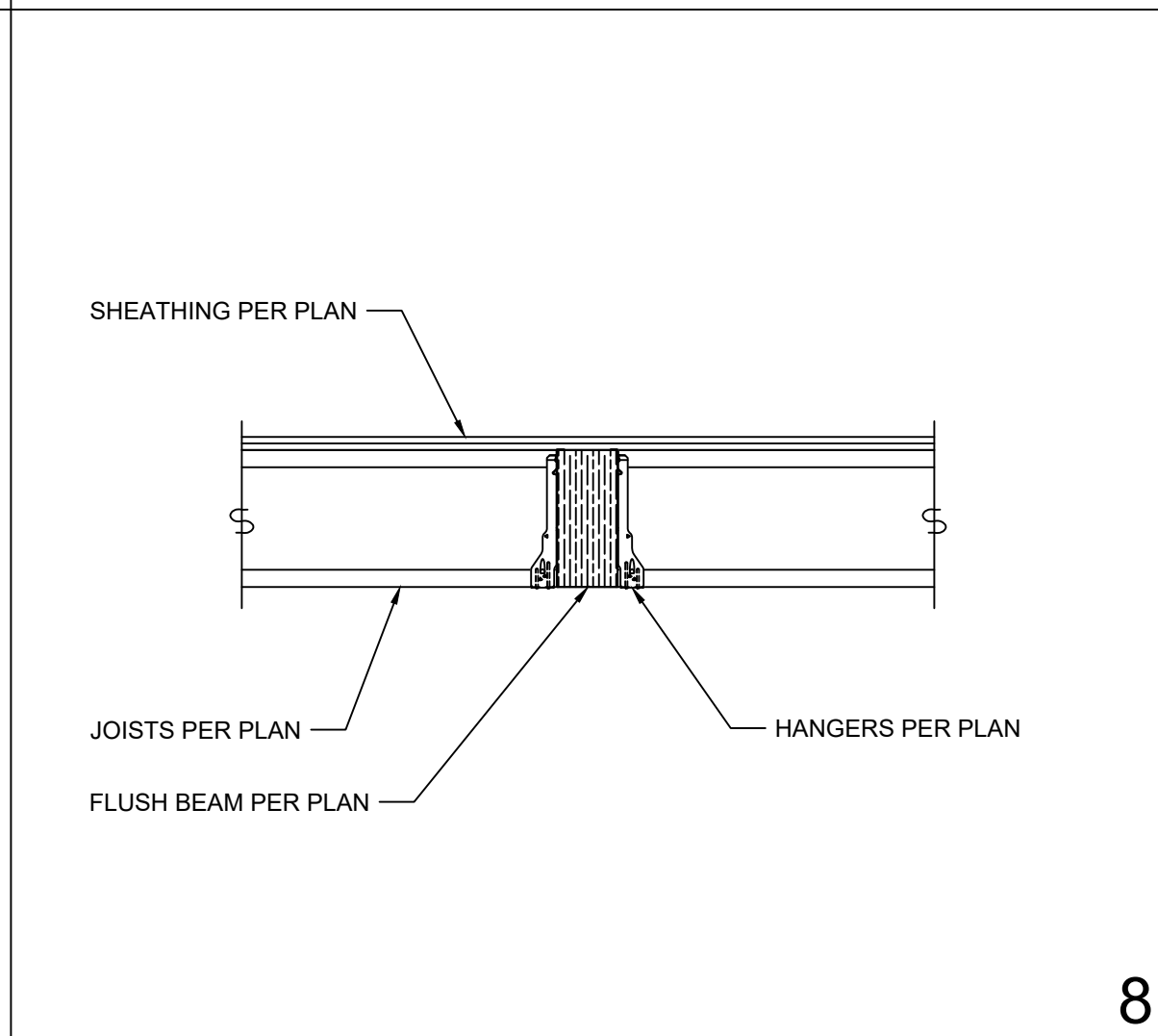

8

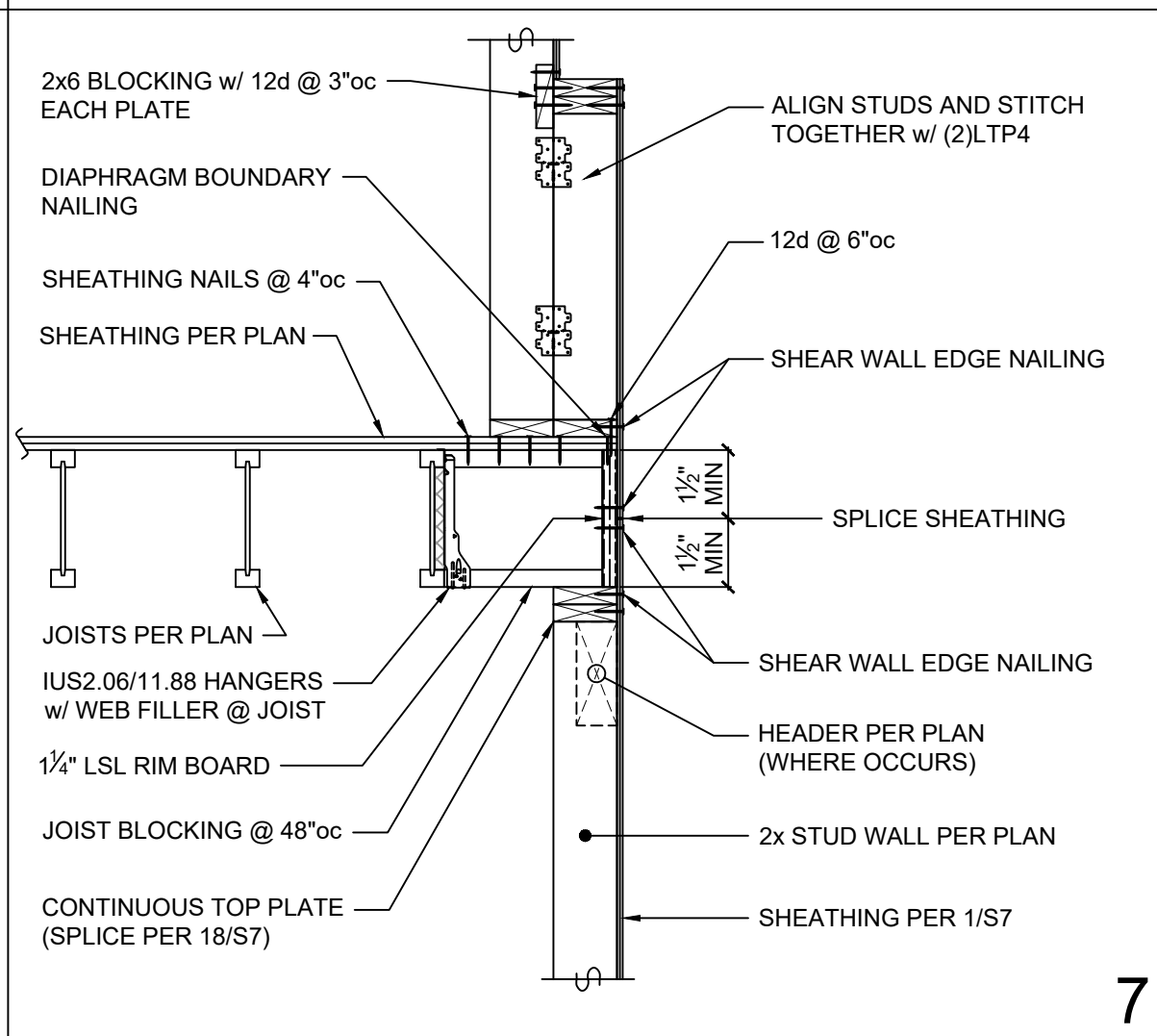

7

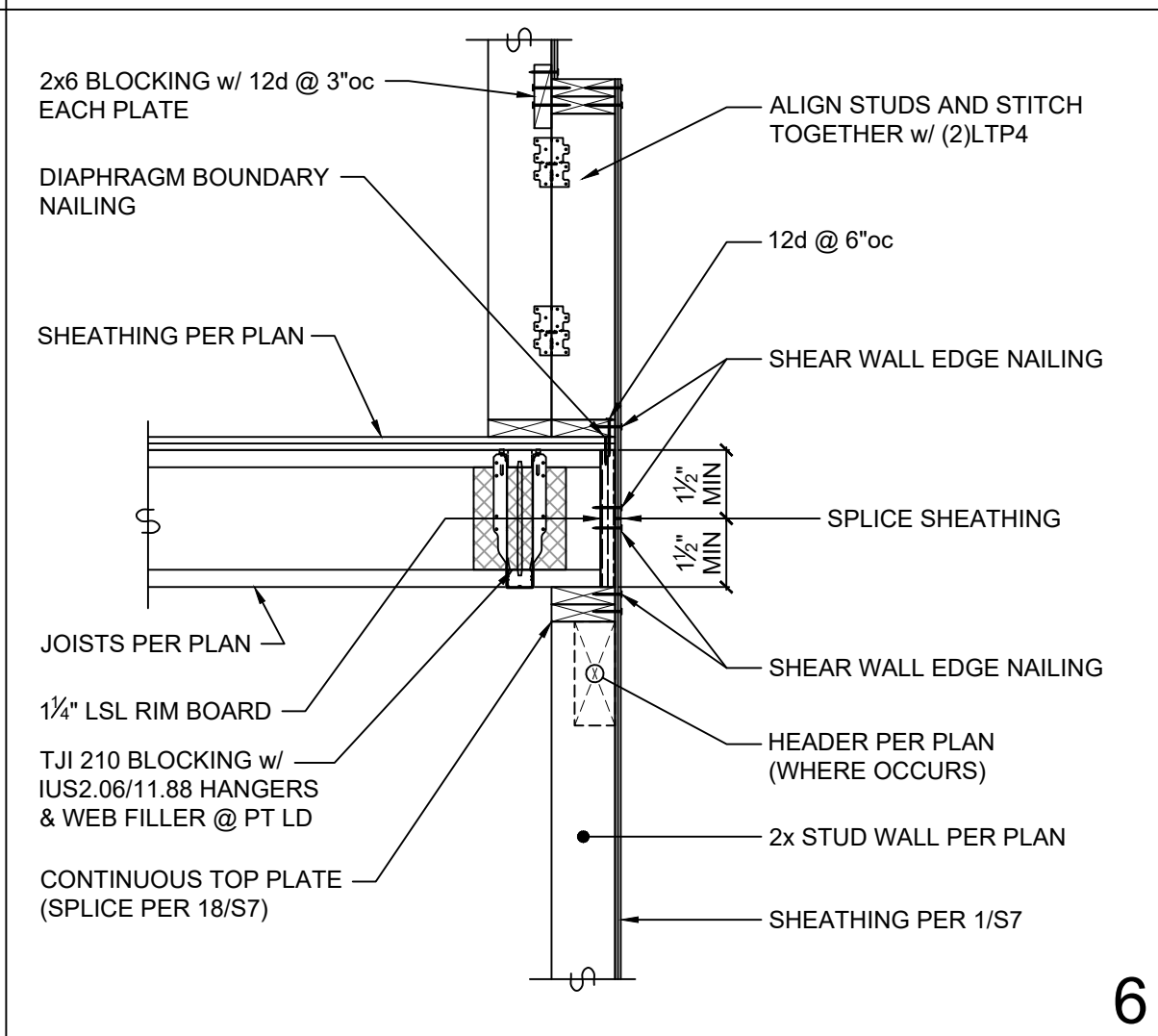

6

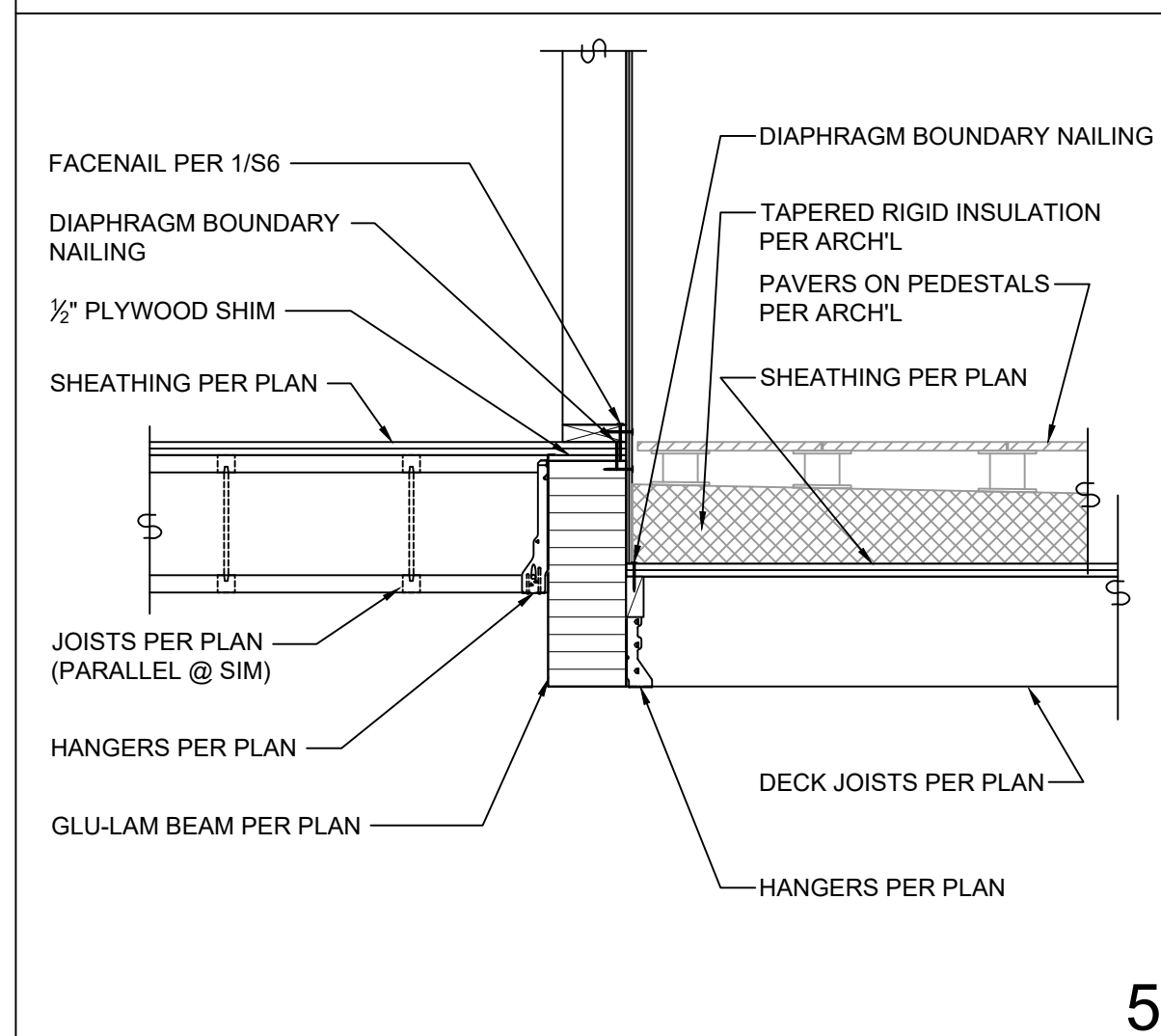

5

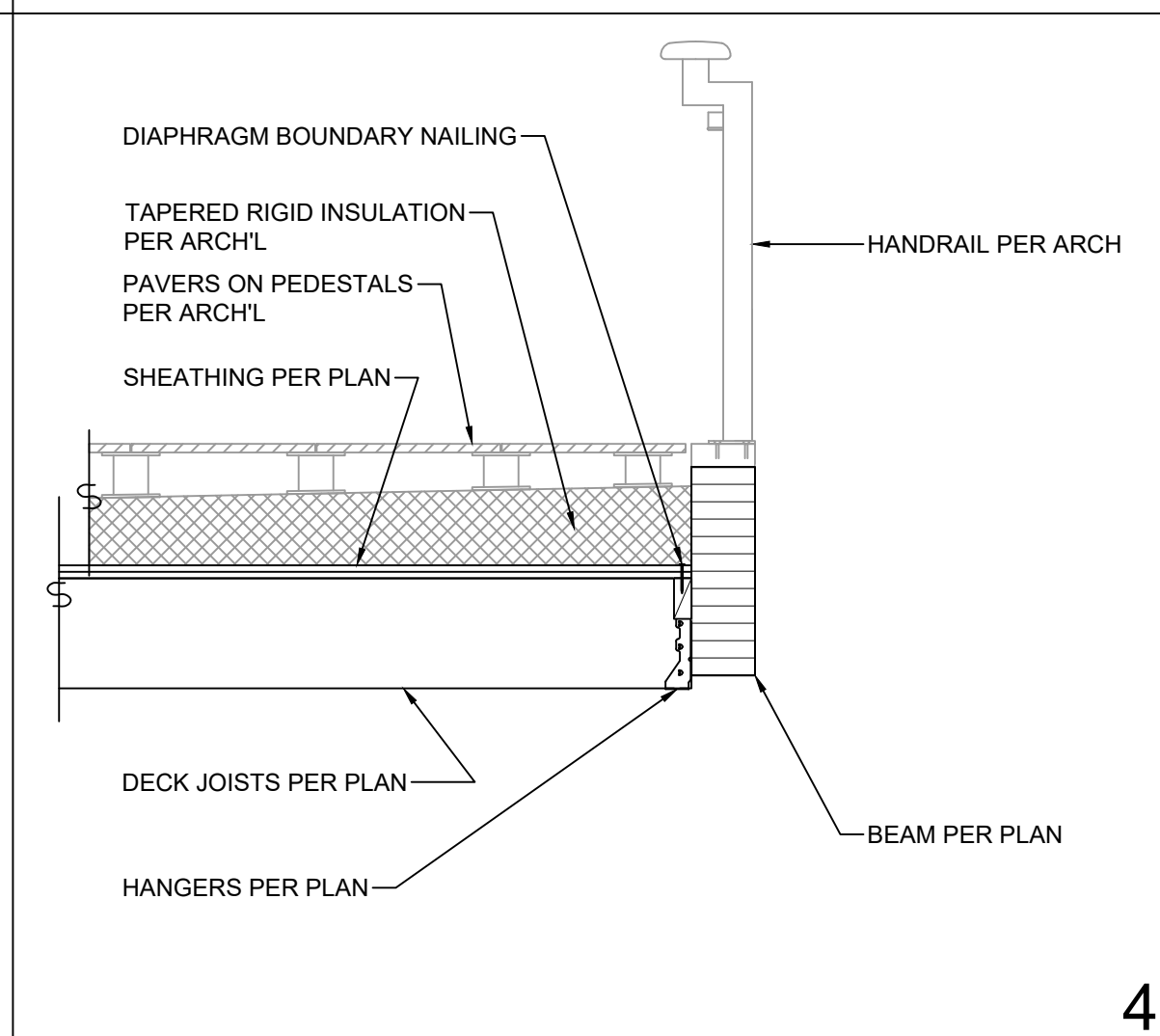

4

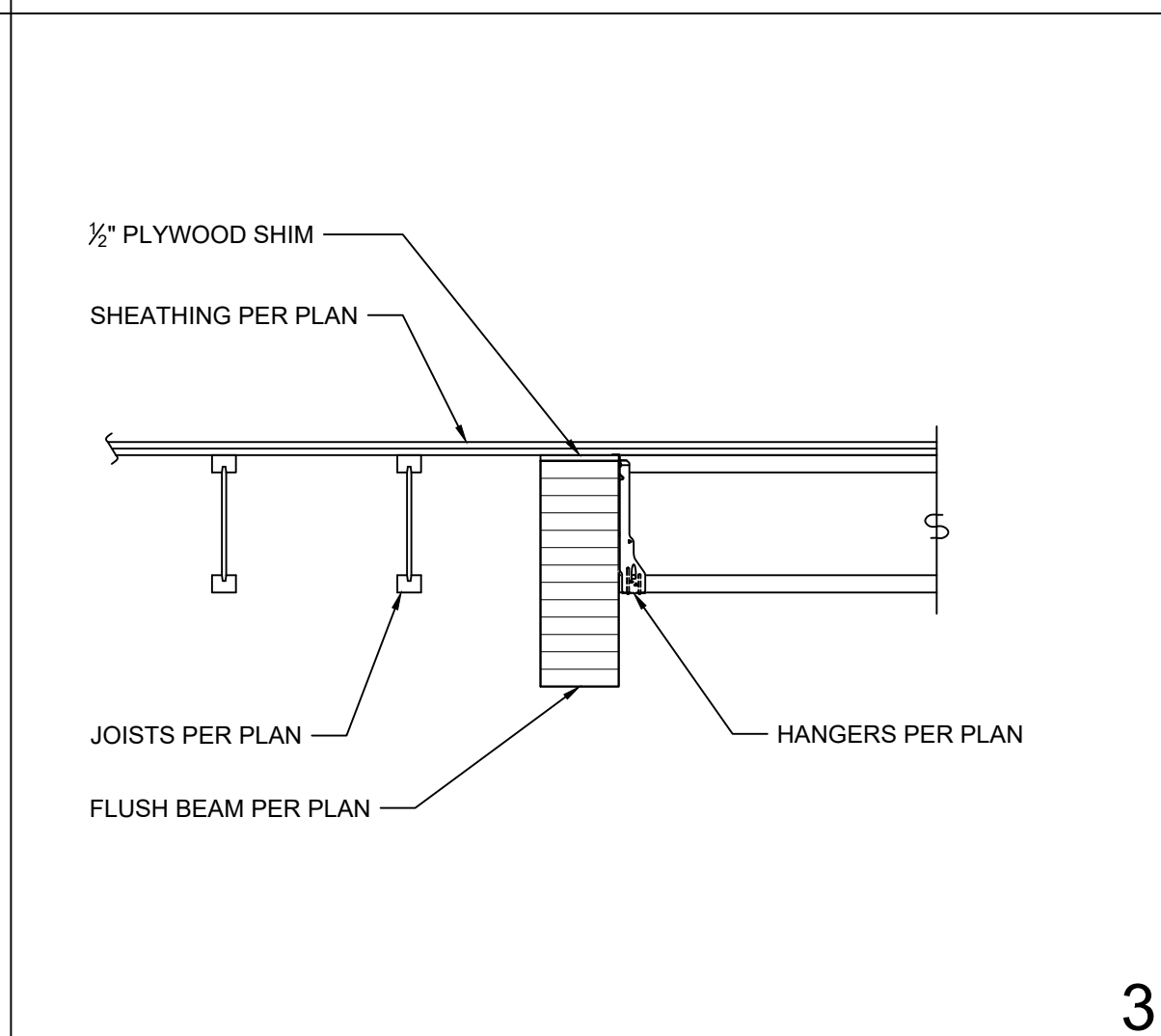

3

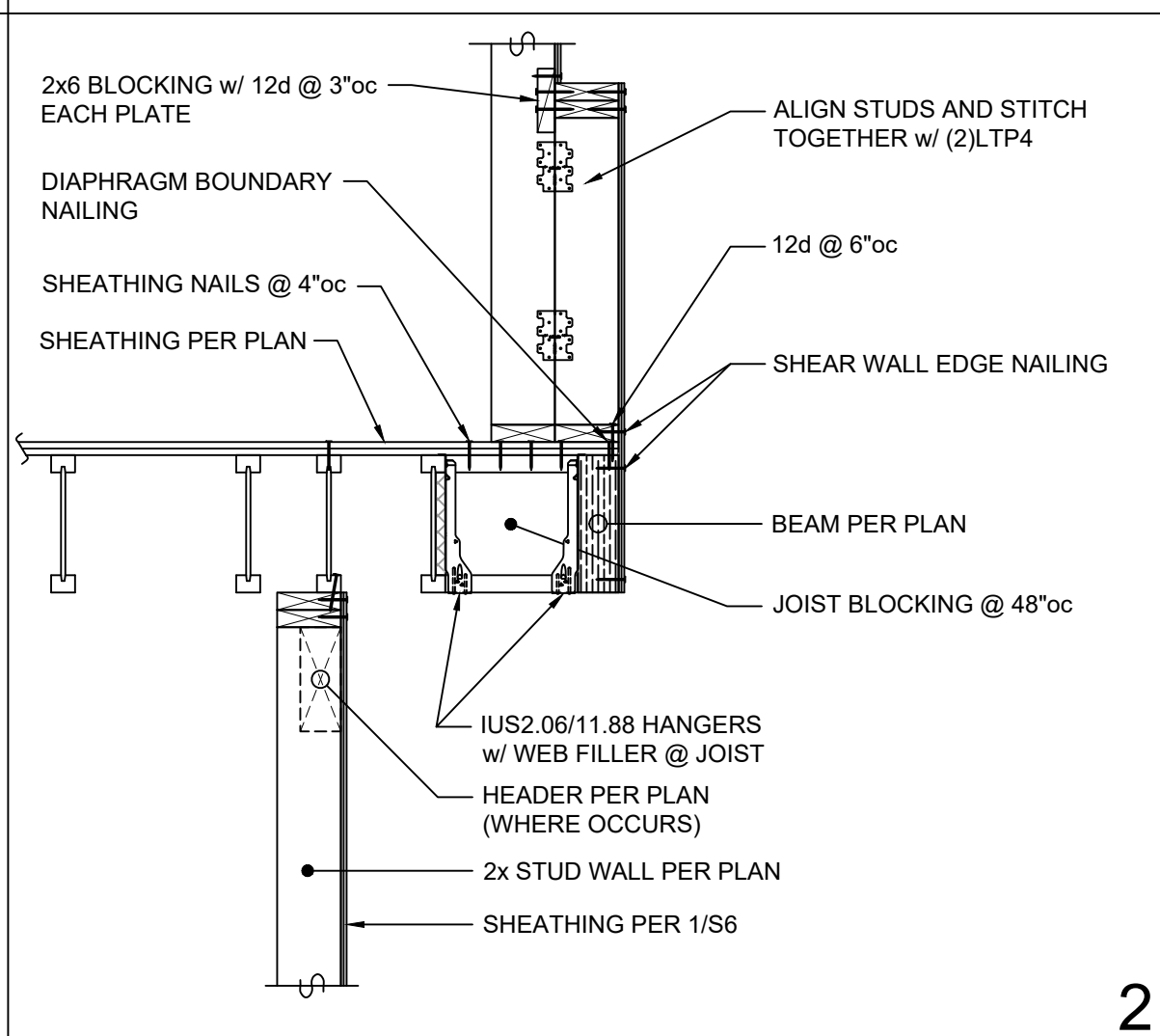

2

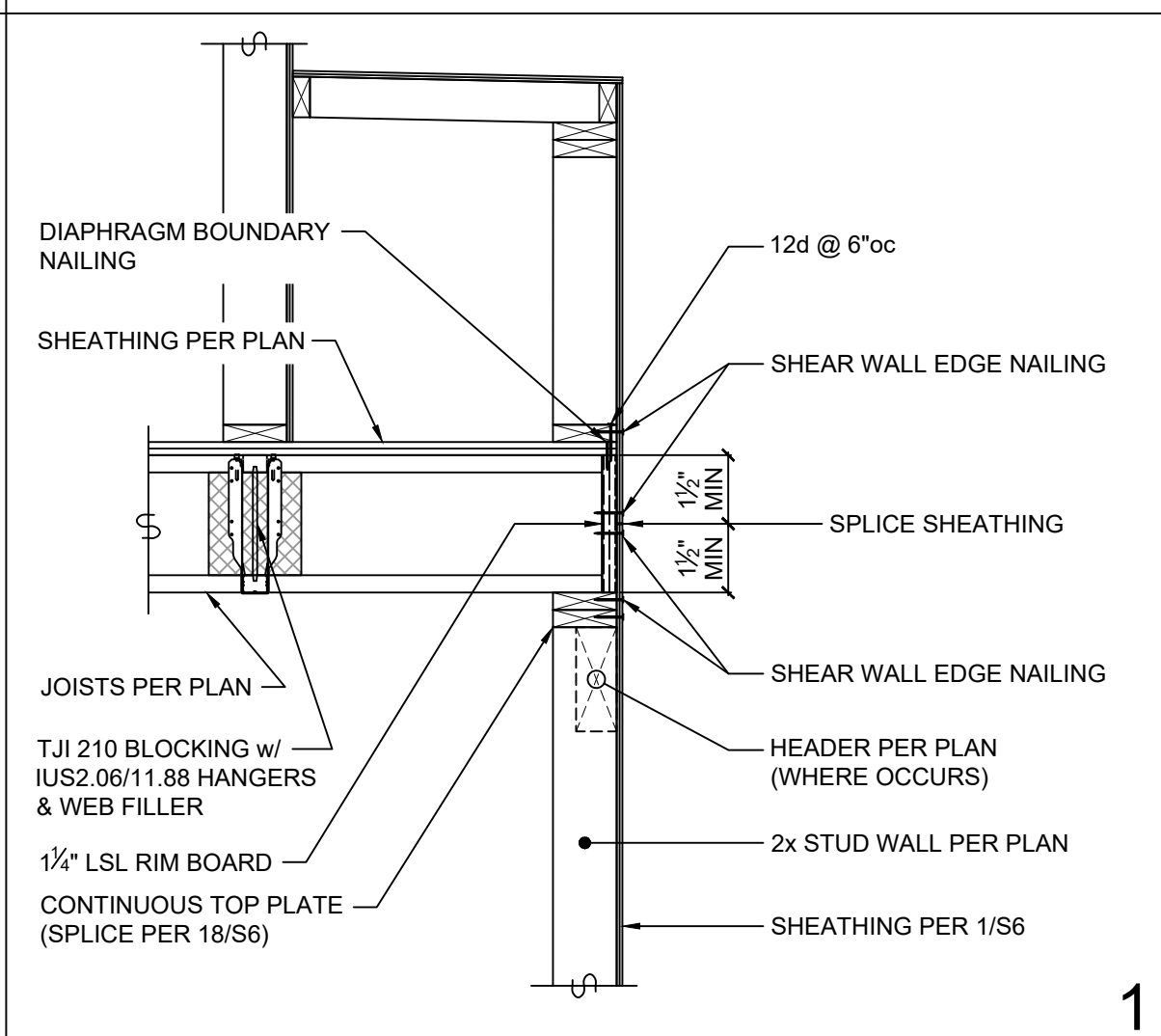

1

